

DB2-B727 DB2-B728

パーツブック
PARTS BOOK
TEILEKATALOG
LIVRE DES PIECES
LIBRO DE REFERENCIA DE PIEZAS

本縫上下送り大釜ミシン

本縫上下送り大釜自動糸切りミシン

SINGLE-NEEDLE TOP AND BOTTOM FEED LOCK STITCHER WITH LARGE HOOK
SINGLE-NEEDLE TOP AND BOTTOM FEED LOCK STITCHER WITH LARGE HOOK
AND THREAD TRIMMER

EINNADEL-STEPPSTICH-SCHNELLNÄHER MIT SCHNELLVERSTELLB. OBER- UND
UNTERTRANSPORT U. GROSSEM GREIFER

EINNADEL-STEPPSTICH-SCHNELLNÄHER MIT SCHNELLVERSTELLB. OBER- UND
UNTERTRANSPORT. GROSSEM GREIFER UND FADENABSCHNEIDER

PIQUEUSE 1 AIGUILLE - POINT NOUE ENTRAINEMENTS SUPERIEURS ET
INFERIEURS AVEC CROCHET GRANDE CAPACITE

PIQUEUSE 1 AIGUILLE - POINT NOUE ENTRAINEMENTS. SUPERIEURS ET
INFERIEURS AVEC CROCHET GRANDE CAPACITE ET COUPE-FILS

1 AGUJA DOBLE ARRASTRE POR PATA PRENSATELAS, GARFIO GRANDE

1 AGUJA DOBLE ARRASTRE POR PATA PRENSATELAS, GARFIO GRANDE CON
CORTAHILOS

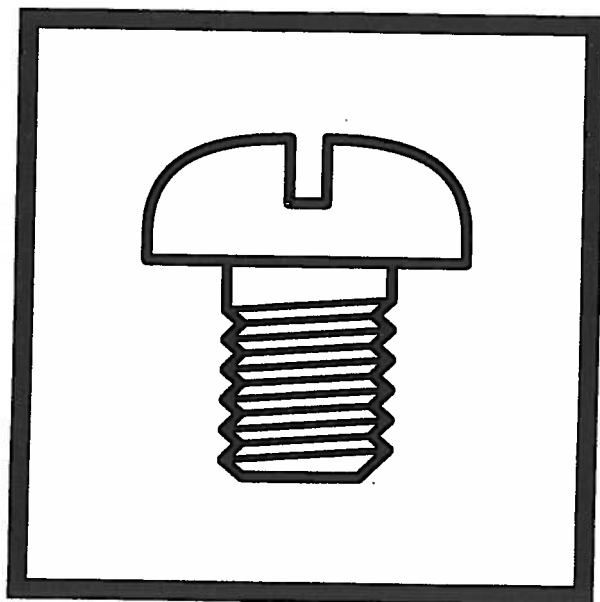

brother®

パーツブックご利用に際して

1. この本は、2000年11月のデータに基づいて作成されたものです。
2. 部品は予告なしに設計変更される場合があります。
3. 組単位で補給する部品は、[]破線で示しております。

目 次

A. 主体関係	1
B. 針棒・天秤関係	3
C. 押工関係	5
D. 送り関係	7
E. 上送り関係	11
F. カマ関係	15
G. 給油潤滑関係	17
H. 糸通シ関係	19
J. 糸切り関係 (B728)	21
K. 逆転関係 (B728)	23
L. 糸緩メ関係 (B728)	23
M. 針位置検出器関係 (B728)	25
N. 逆転スイッチ関係 (B728)	25
Z. 付属品関係	27
Ga. ゲージ部品一覧表	29
Wa. 警告ラベル	30
索引	31

Notes for using this parts book

1. This book was prepared based on information available in November 2000.
2. Parts are subject to changes in design without prior notice.
3. Parts supplied as complete assemblies are circled by a dotted line .

CONTENTS

A. Machine body	1	J. Thread trimmer mechanism (B728)	21
B. Needle bar and thread take-up mechanism	3	K. Quick reverse mechanism (B728)	23
C. Presser foot mechanism	5	L. Tension release mechanism (B728)	23
D. Feed mechanism	7	M. Synchronizer (B728)	25
E. Upper feed mechanism	11	N. Quick reverse switch mechanism (B728)	25
F. Rotary hook mechanism	15	Z. Accessories	27
G. Lubrication	17	Ga. Gauge parts List	29
H. Threading mechanism	19	Wa. Warning labels	30
		INDEX	31

Hinweise zur Verwendung dieser Teileliste

1. Dieses Buch basiert auf den Informationen vom November 2000.
2. Modelländerungen sind vorbehalten.
3. Die Teile, die als kompletter Satz geliefert werden, sind mit einer  gestrichelten Linie umrandet.

INHALTSVERZEICHNIS

A. Maschinengehäuse	1	J. Fadenabschneidevorrichtung (B728) ...	21
B. Nadelstange und Fadenabnahmevorrichtung	3	K. Umkehr (B728)	23
C. Stoffdrückerfuß	5	L. Spannungsverminderungsvorrichtung (B728)	23
D. Transportvorrichtung	7	M. Synchronisator (B728)	25
E. Obertransportvorrichtung	11	N. Umkehrschalter (B728)	25
F. Greifervorrichtung	15	Z. Zubehör	27
G. Schmierung	17	Ga. Lehrenliste	29
H. Fadenführungsvorrichtung	19	Wa. Warnschilder	30
		VERZEICHNIS	31

Notes sur l'utilisation de ce manuel de pièces détachées



1. Ce manuel a été fait d'après les renseignements valables au mois de Novembre 2000.
2. Les pièces peuvent être sujettes à des modifications sans préavis.
3. Les pièces fournies en tant qu'assemblages complets sont encadrées avec un trait pointillé .

TABLE DES MATIERES

A. Corps de la machine	1	K. Mécanisme de marche arrière rapide (B728)	23
B. Mécanisme de la barre à aiguille et releveur de fil	3	L. Mécanisme de la lâche de tension (B728)	23
C. Mécanisme de pied presseur	5	M. Synchronisateur (B728)	25
D. Mécanisme de l'entraînement	7	N. Mécanisme de interrupteur de marche arrière rapide (B728)	25
E. Mécanisme de l'entraînement supérieur	11	Z. Accessoires	27
F. Mécanisme du crochet rotatif	15	Ga. Liste des Pièces de cartment	29
G. Lubrification	17	Wa. Etiquettes d'avertissement	30
H. Mécanisme de l'enfilage	19	INDEX	31
J. Mécanisme de coupe-fil (B728)	21		

Notas para usar este Manual de Piezas

1. Este libro ha sido compilado basándose en los datos de que se disponía en noviembre 2000.
2. Las piezas quedan sujetas a cambios de diseño sin aviso previo.
3. Las piezas suministradas como conjuntos completos se enmarcan con una línea punteada .

INDICE

A. Cuerpo de la máquina	1	J. Mecanismo de la cortadura de hiros (B728)	21
B. Mecanismo de la barra de aguja y tirahilos	3	K. Mecanismo de la inversión rápida (B728)	23
C. Mecanismo de la prensa tela	5	L. Mecanismo relajador de tensión (B728)	23
D. Mecanismo de la alimentación	7	M. Sincronizador (B728)	25
E. Mecanismo de la alimentación superior	11	N. Mecanismo del conmutador de inversión rápida (B728)	25
F. Mecanismo del cangrejo	15	Z. Accesorios	27
G. Lubricación	17	Ga. Lista d'ePiezas de calibradores	29
H. Mecanismo del enhebrado	19	Wa. Etiquetas de advertencia	30
		INDICE	31

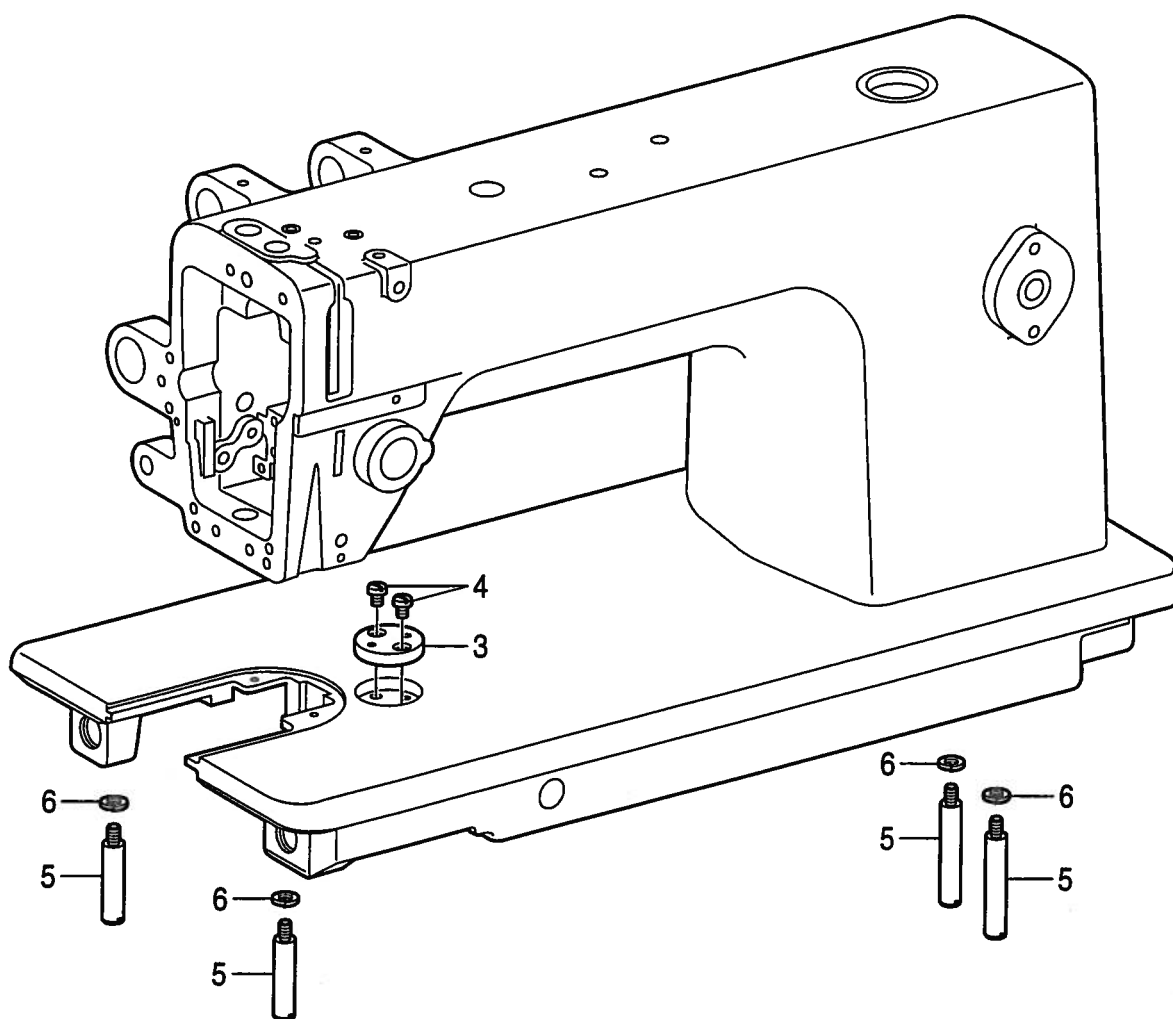

A. 主体関係 / Machine body / Maschinengehäuse / Corps de la machine / Cuerpo de la máquina

REF.NO.	CODE	Q'TY	ヒンメイ	NAME OF PARTS	RM
3	SW0003001	1	ジヨウギイタ	RULER PLATE	
4	SW0004001	2	ジヨウギイタトメネジ	SCREW, PAN SM4.37-40X5.5	
5	SW0005001	4	キヤクチュウ	BED LEG	
6	SW0006001	4	バネザガネ	WASHER, SPRING	

B. 針棒・天秤關係 / Needle bar and thread take-up mechanism / Nadelstange und Fadenabnahmevorrichtung / Mécanisme de la barre à aiguille et releveur de fil / Mecanismo de la barra de aguja y tirahflos

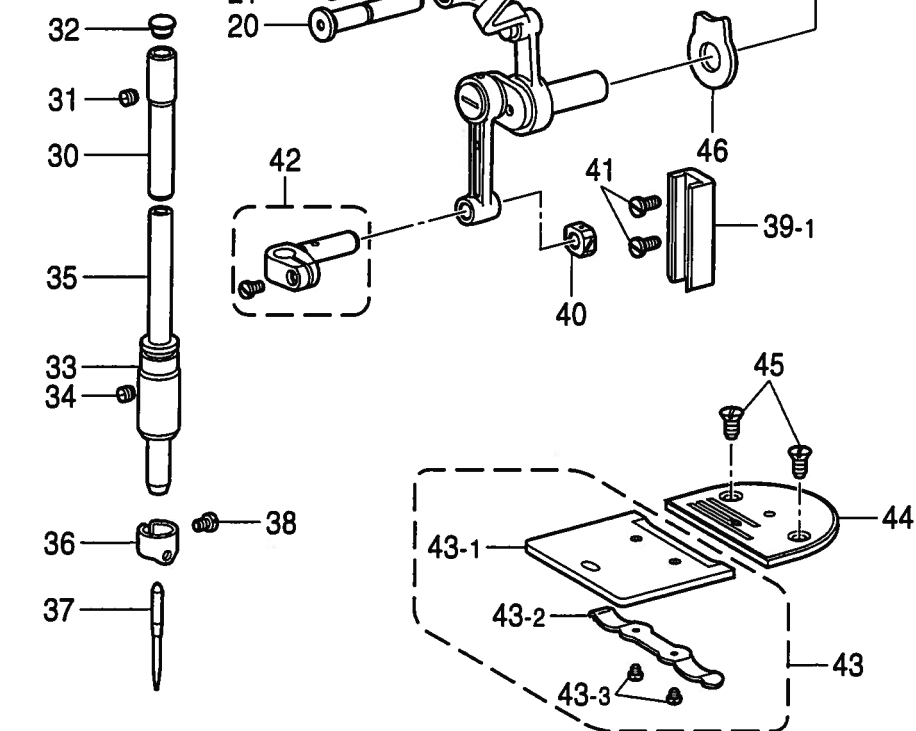
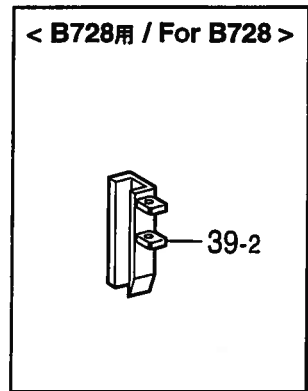
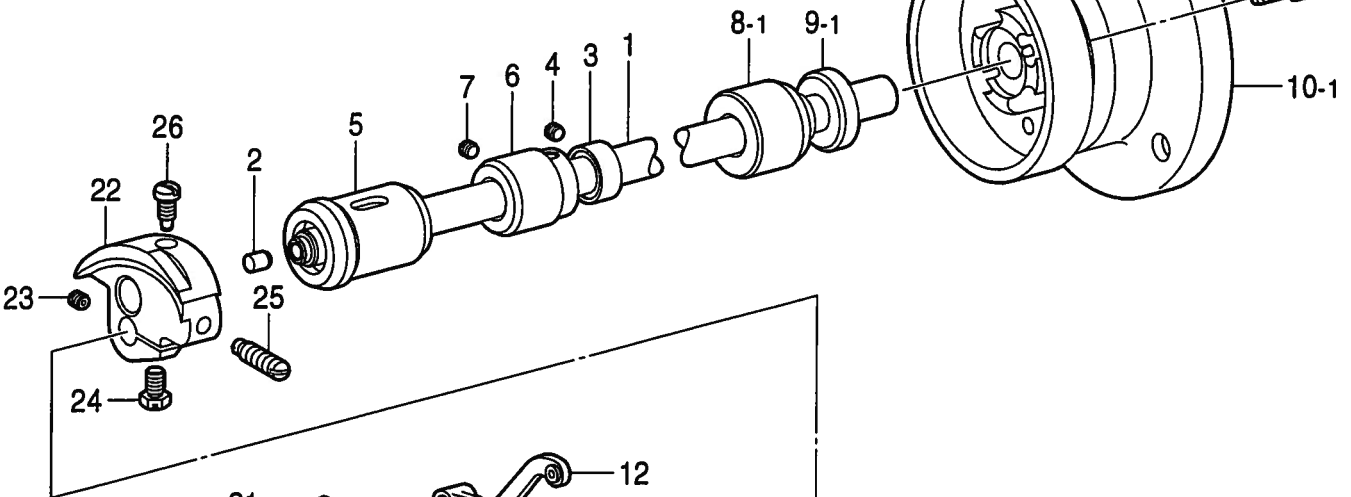
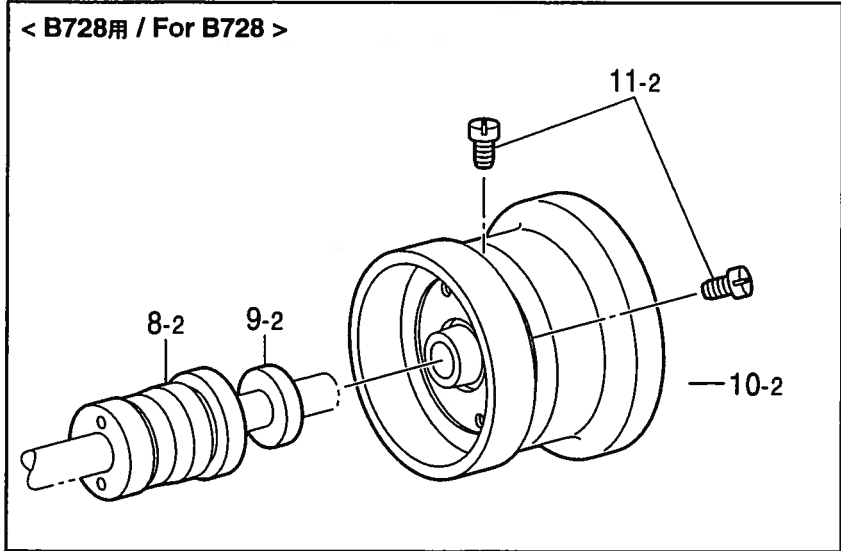

B. 針棒・天秤関係 / Needle bar and thread take-up mechanism / Nadelstange und Fadenabnahmevorrichtung /
Mécanisme de la barre à aiguille et releveur de fil / Mecanismo de la barra de aguja y tirahilos

REF.NO.	CODE	Q'TY	ヒンメイ	NAME OF PARTS	RM
1	SW0010001	1	ウワジク	UPPER SHAFT	
2	SW0011001	2	ゴムセン	RUBBER CAP	
3	SW0012001	1	セットカラー	SET SCREW COLLAR	
4	SW0013001	2	トメネジ635X40X4	SET SCREW, SM6.35-40X4	
5	SW0014001	1	ウワジクメタルL	BUSH, L	
6	SW0015001	1	ウワジクメタルM	BUSH, M	
7	SW0016001	1	トメネジ595X28X10	SET SCREW, SM5.95-28X10	

8-1	SW0017001	1	ウワジクメタルR	<For B727> BUSH, R	
9-1	SW0018001	1	オイルシール	OIL SEAL	
10-1	SW0019001	1	プーリ	PULLEY	
11-1	SW0020001	2	トメネジ595X28X27	SET SCREW, SM5.95-28X27	

8-2	S02524001	1	ウワジクメタルR	<For B728> BUSH, R ; U-SHAFT	
9-2	101487000	1	オイルシール	OIL SEAL	
10-2	SW0506001	1	プーリ	PULLEY	
11-2	S33689002	2	アタマトメクボミ 595-14	SET SCREW, (CP) SM5.95-28X14	

12	SW0021001	1	ハリボウレンカクミ	THREAD TAKE-UP LEVER SET	
20	SW0030001	1	テンピンササエジク	SUPPORT SHAFT	
21	SW0016001	1	トメネジ595X28X10	SET SCREW, SM5.95-28X10	
22	SW0032001	1	テンピンクランク	THREAD TAKE-UP CRANK	
23	SW0033001	1	トメネジ635X40X7	SET SCREW, SM6.35-40X7	
24	SW0034001	1	ハリボウクランクトメネジ	SCREW, SM6.35-40X10.5	
25	SW0035001	1	テンピンクランクトメネジ	SCREW, SM7.14-28X18	
26	SW0036001	1	テンピンクランクトメネジ	SCREW, SM7.14-28X17	
30	SW0040001	1	ハリボウメタルU	BUSH, U	
31	SW0041001	1	トメネジ595X28X5	SET SCREW, SM5.95-28X5	
32	SW0042001	1	キャップ	CAP	
33	SW0504001	1	ハリボウメタルD	BUSH, D	
34	SW0044001	1	トメネジ437X40X3	SET SCREW, SM4.37-40X3	

35	SW0045001	1	<B727用> ハリボウ	<For B727> NEEDLE BAR	
35	SW0503001	1	<B728用> ハリボウ	<For B728> NEEDLE BAR	

36	SW0046001	1	ハリボウイトアンナイ	THREAD GUIDE	
37	145646023	1	ミシンハリDPX17	NEEDLE, DPX17 (#23)	
38	SW0048001	1	ハリトメネジ	SET SCREW, SM3.18-44X4.5	

39-1	SW0049001	1	<B727用> ハリボウアンナイ	<For B727> GUIDE, N-BAR	
39-2	SW0505000	1	<B728用> ハリボウアンナイ	<For B728> GUIDE, N-BAR	

40	SW0050001	1	ハリボウアンナイカクコマ	SLIDE BLOCK	
41	SW0051001	2	ハリボウアンナイシメネジ	SCREW, SM4.37-40X8	
42	SW0052001	1	ハリボウダキ	NEEDLE BAR CLAMP	
43	SW0053001	1	スベリイタクミ	SLIDE PLATE ASSY	
43-1	SW0054001	1	スベリイタ	SLIDE PLATE	
43-2	SW0055001	1	スベリイタバネ	SPRING, PLATE	
43-3	SW0056001	2	スベリイタバネシメネジ	SCREW, SM2.38-56X2.5	

44	SW0057001	1	<B727用> ハリイタ	<For B727> NEEDLE PLATE	
44	147322101	1	<B728用> ハリイタC26	<For B728> NEEDLE PLATE, C26	

45	SW0058001	2	ハリイタサラネジ	SCREW, SM4.37-40X8	
46	SW0489001	1	ザガネ	WASHER, PLAIN	

C. 押工関係 / Presser foot mechanism / Stoffdrückerfuß / Mécanisme de pied presseur /
 Mecanismo de la prensa tela

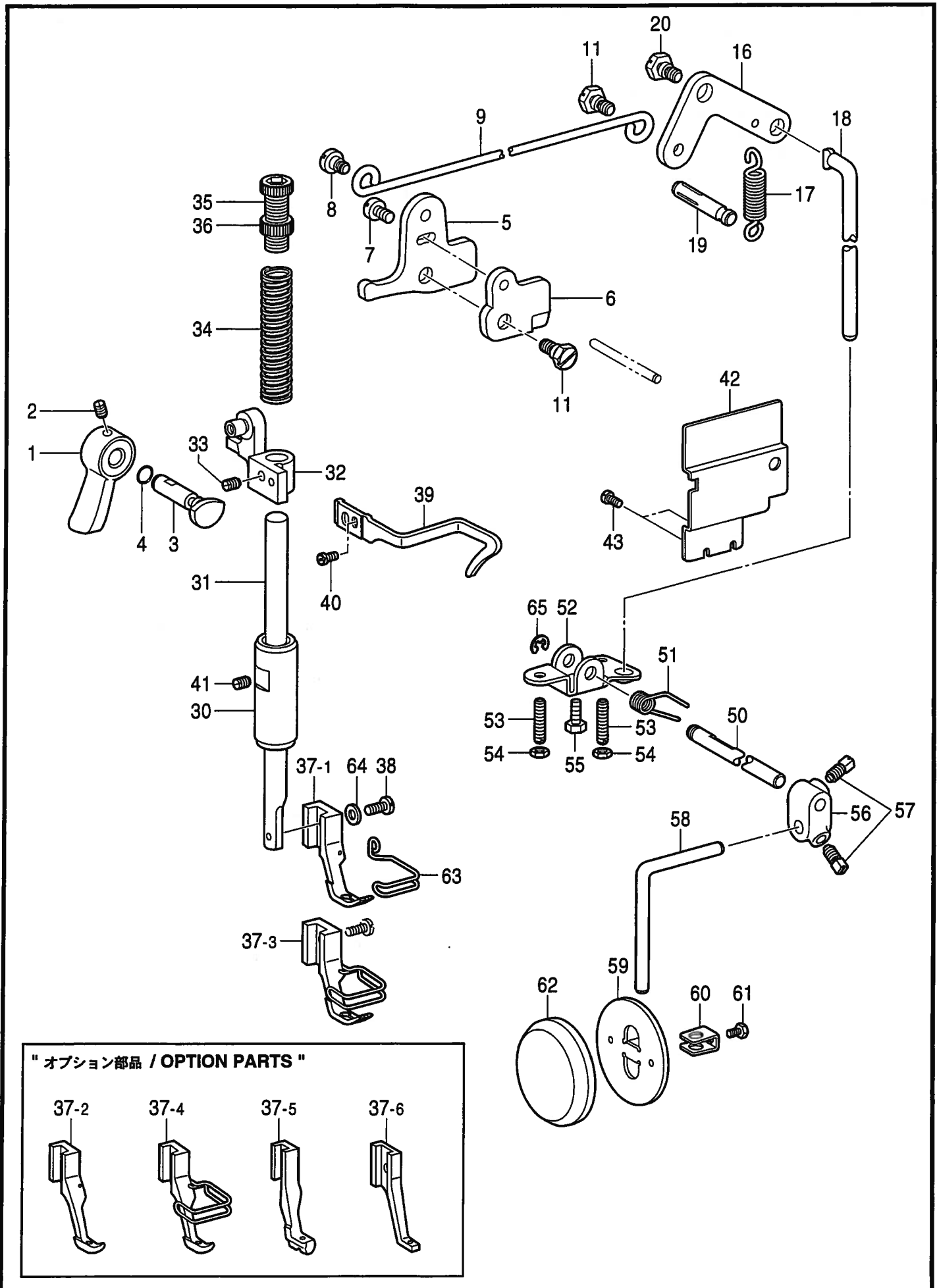

C. 押工関係 / Presser foot mechanism / Stoffdrückerfuß / Mécanisme de pied presseur / Mecanismo de la prensa tela

REF.NO.	CODE	Q'TY	ヒンメイ	NAME OF PARTS	RM
1	SW0060001	1	オサエアゲテコ	PRESSER BAR LIFTER	
2	SW0061001	1	オサエアゲテコトメネジ	SET SCREW, SM4.37-40X6.6	
3	SW0062001	1	オサエアゲクランク	LIFTER CRANK, P-BAR	
4	SW0063001	1	Oリング	O RING	
5	SW0064001	1	オサエアゲレバー	LIFTER LEVER, ;P-BAR	
6	SW0065001	1	<B727用> アンナイイタ	<For B727> GUIDE PLATE	
6	SW0507001	1	<B728用> アンナイイタ	<For B728> GUIDE PLATE	
7	SW0066001	1	オサエアゲレバーシメネジ	SCREW, SM4.37-40X6.5	
8	SW0067001	1	アゲレバーダンネジ	SHOULDER SCREW, SM4.37	
9	SW0068001	1	ヒザアゲレンカン	CONNECTING ROD, ;K-LIFTER	
11	SW0069001	2	レンカندانネジ	SHOULDER SCREW, SM5.95	
16	SW0071001	1	ヒザアゲレバー	LEVER, K-LIFTER	
17	SW0072001	1	ヒザアゲレバーバネ	SPRING, EXTENSION	
18	SW0073001	1	ヒザアゲボウ	KNEE LIFTER BAR	
19	SW0074001	1	バネカケ	SPRING HOOK	
20	SW0075001	1	ヒザアゲレバダンネジ	SHOULDER SCREW, SM5.95	
30	SW0076001	1	オサエボウメタル	BUSH, ;P-BAR	
31	SW0077001	1	オサエボウ	PRESSER BAR	
32	SW0078001	1	オサエボウダキ	GUIDE BRACKET, ;P-BAR	
33	SW0079001	1	トメネジ595X28X8	SET SCREW, SM5.95-28X8	
34	SW0080001	1	オサエバネ	SPRING, COMPRESSION	
35	SW0081001	1	オサエチヨウセツネジ	ADJUSTING SCREW, PRESSER	
36	SW0082001	1	チヨウセツネジツマミナツト	ADJUSTING NUT, PRESSER	
37-1	SW0083001	1	オサエアシ	PRESSER FOOT	
37-3	SW0105001	1	オサエアシクミ	PRESSER FOOT ASSY, W/F-GUARD	
38	SW0084001	1	オサエアシトリツケネジ	SCREW, SM3.57-40X11	
39	SW0085001	1	オサエボウダキイトカケ	THREAD HOOK	
40	SW0086001	1	シメネジ437X40X6	SCREW, SM4.37-40X6	
41	SW0044001	1	トメネジ437X40X3	SET SCREW, SM4.37-40X3	
42	SW0088001	1	オイルシヤヘイカバー	OIL GUARD	
43	SW0086001	2	シメネジ437X40X6	SCREW, SM4.37-40X6	
50	SW0090001	1	ヒザアゲヨコジク	LIFTER SHAFT	
51	SW0091001	1	ヒザアゲバネ	SPRING	
52	SW0092001	1	ヒザアゲブラケット	BRACKET	
53	SW0093001	2	ヒザアゲチヨウセツネジ	ADJUSTING SCREW	
54	SW0094001	2	ヒザアゲチヨウセツナツト	ADJUSTING NUT	
55	SW0020001	1	トメネジ595X28X27	SET SCREW, SM5.95-28X27	
56	SW0096001	1	ヒザアテツギテ	BRACKET	
57	SW0097001	2	ヒザアテツギテカクボルト	BOLT, SQUARE SM7.94-18X13	
58	SW0098001	1	ヒザアゲタテジク	LIFTER BAR	
59	S34756001	1	ヒザアテ	KNEE LIFTER PLATE	
60	SW0100001	1	ヒザアテストツパー	STOPPER	
61	SW0101001	1	ヒザアテストツパーネジ	SCREW, SM5.95-28X8	
62	S31885001	1	ヒザアテカバー	COVER, ;K-LIFTER PLATE	
63	SW0103001	1	フィンガーガード	FINGER GUARD	
64	SW0385001	1	ガワイタシメネジワツシヤ	WASHER, PLAIN	
65	SW0396001	1	トメワ	RETAINING RING, E	
37-2	S04502101	1	" オプション部品 "	" OPTION PARTS "	
37-4	S36917001	1	オサエアシ	PRESSER FOOT	
37-5	151850001	1	オサエアシRクミ	PRESSER FOOT ASSY, R-W/FG	
37-6	151852001	1	ナカオサエ	INNER PRESSER FOOT	
		1	コモノヌイヨウオサエナカ	PRESSER FOOT	

D. 送り関係 / Feed mechanism / Transportvorrichtung / Mécanisme de l'entraînement / Mecanismo de la alimentación

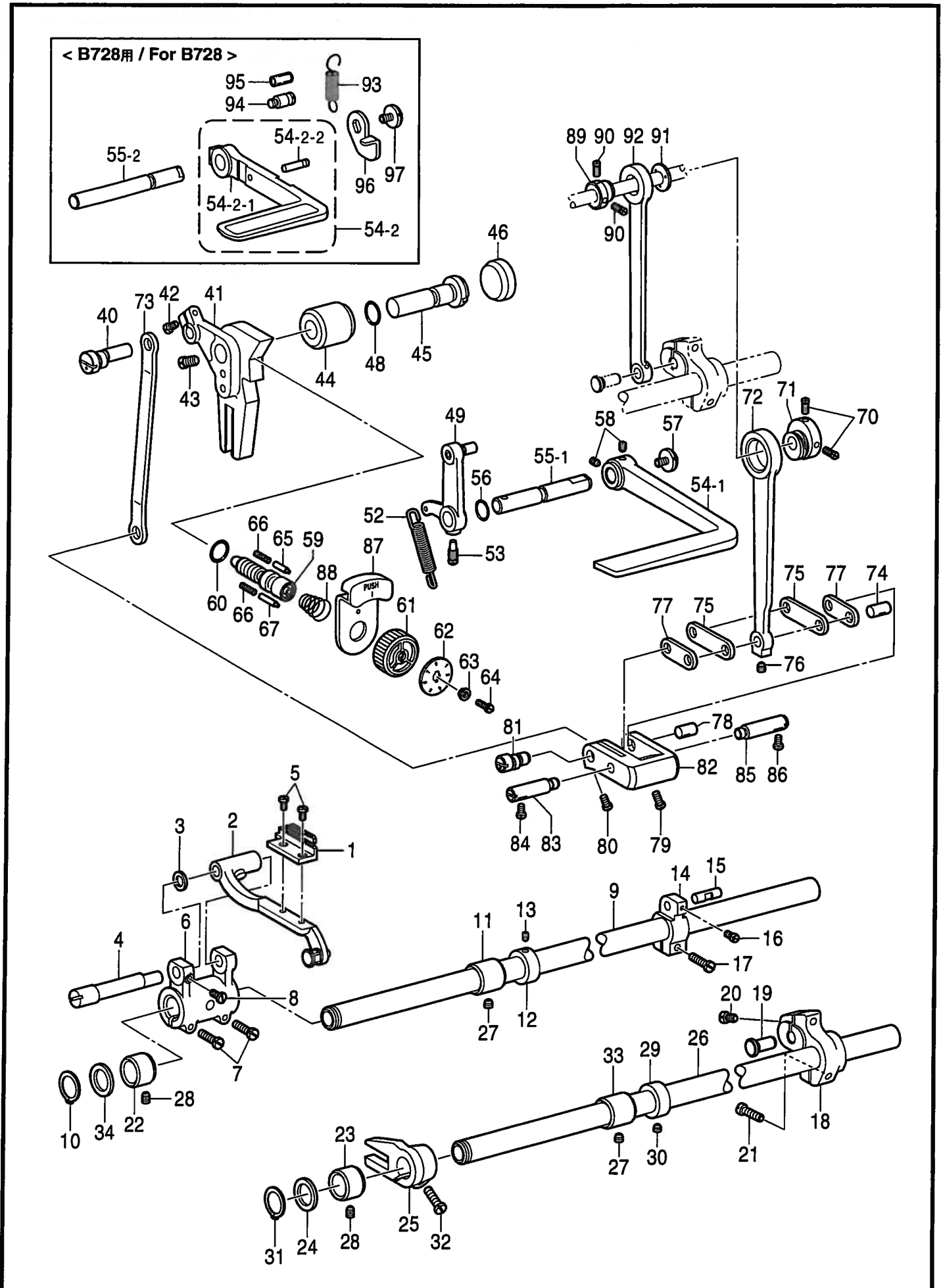

D. 送り関係 / Feed mechanism / Transportvorrichtung / Mécanisme de l'entraînement /
Mecanismo de la alimentación

REF.NO.	CODE	Q'TY	ヒンメイ	NAME OF PARTS	RM
1	SW0120001	1	<B727用> オクリバ	<For B727> FEED DOG	
1	S06629001	1	<B728用> オクリバ	<For B728> FEED DOG	
2	SW0121001	1	オクリダイ	FEED BAR	
3	SW0122001	1	オクリダイワツシャー	WASHER, PLAIN	
4	SW0123001	1	オクリダイジク	SHAFT	
5	SW0124001	2	オクリバシメネジ	SCREW, SM3.18-44X6	
6	SW0125001	1	スイハイオクリダイウデ	FEED ROCKER ARM	
7	SW0126001	2	シメネジ476X28X15	SCREW, SM4.76-28X15	
8	SW0127001	1	オクリダイジクトメネジ	SCREW, SM4.37-40X8	
9	SW0128001	1	スイハイオクリジク	SHAFT, ;F-ROCKER	
10	SW0129001	1	Cガタトメワ	RETAINING RING, C	
11	SW0130001	1	スイハイオクリジクメタルM	BUSH, M	
12	SW0131001	1	オクリジクセツトカラー	SET SCREW COLLAR	
13	SW0013001	2	トメネジ635X40X4	SET SCREW, SM6.35-40X4	
14	SW0133001	1	スイハイオクリウデ	FEED ROCKER ARM	
15	SW0134001	1	スイハイオクリウデジク	STUD	
16	SW0135001	1	トメネジ437X40X5	SET SCREW, SM4.37-40X5	
17	SW0136001	1	シメネジ437X40X12	SCREW, SM4.37-40X12	
18	SW0137001	1	UDオクリジクウデ	FEED LIFTING ARM, UD	
19	SW0138001	1	UDオクリジクウデピン	PIN	
20	SW0126001	1	シメネジ476X28X15	SCREW, SM4.76-28X15	
21	SW0140001	1	オクリジクウデシメネジ	SCREW, SM4.76	
22	SW0141001	1	オクリジクメタルL	BUSH, L	
23	SW0141001	1	オクリジクメタルL	BUSH, L	
24	SW0142001	1	ジヨウゲジクワツシャー	WASHER, PLAIN	
25	SW0143001	1	ジヨウゲオクリウデ	FEED LIFTING ARM	
26	SW0144001	1	ジヨウゲオクリジク	SHAFT	
27	SW0041001	2	トメネジ595X28X5	SET SCREW, SM5.95-28X5	
28	SW0016001	2	トメネジ595X28X10	SET SCREW, SM5.95-28X10	
29	SW0131001	1	オクリジクセツトカラー	SET SCREW COLLAR	
30	SW0013001	2	トメネジ635X40X4	SET SCREW, SM6.35-40X4	
31	SW0129001	1	Cガタトメワ	RETAINING RING, C	
32	SW0150001	1	UDオクリウデシメネジ	SCREW, SM4.37	
33	SW0130001	1	スイハイオクリジクメタルM	BUSH, M	
34	SW0142001	1	ジヨウゲジクワツシャー	WASHER, PLAIN	
40	SW0160001	1	キリカエキレンカンジク	CONNECTING STUD	
41	SW0161001	1	オクリチヨウセツキ	FEED REGULATOR	
42	SW0136001	1	シメネジ437X40X12	SCREW, SM4.37-40X12	
43	SW0163001	1	チヨウセツキジクトメネジ	SCREW, SM5.95-28X8.5	
44	SW0164001	1	オクリチヨウセツキジクメタル	BUSH	
45	SW0165001	1	オクリチヨウセツキジク	SHAFT, ;F-REGULATOR	
46	SW0166001	1	ゴムセン	RUBBER CAP	
48	SW0176001	1	レバージクOリング	O RING	
49	SW0169001	1	レバーピンクミ	PIN ASSY, LEVER	
52	SW0172001	1	ヒキバネ	SPRING, EXTENSION	
53	SW0173001	1	レバートメネジ	SCREW, SM5.95-28X14.5	
54-1	SW0174001	1	<B727用> カエシヌイレバー	<For B727> REVERSE STITCHING LEVER	
55-1	SW0175001	1	カエシヌイレバージク	SHAFT, R-LEVER	
54-2	S45840101	1	<B728用> カエシヌイレバークミ	<For B728> REVERSE STITCHING LEVER ASSY	
54-2-1	S45841101	1	カエシヌイレバー	REVERSE STITCHING LEVER	
54-2-2	S02561021	1	バネカケピン	SPRING HOOK PIN	
55-2	SW0508001	1	カエシヌイレバージク	SHAFT, R-LEVER	

D. 送り関係 / Feed mechanism / Transportvorrichtung / Mécanisme de l'entraînement / Mecanismo de la alimentación

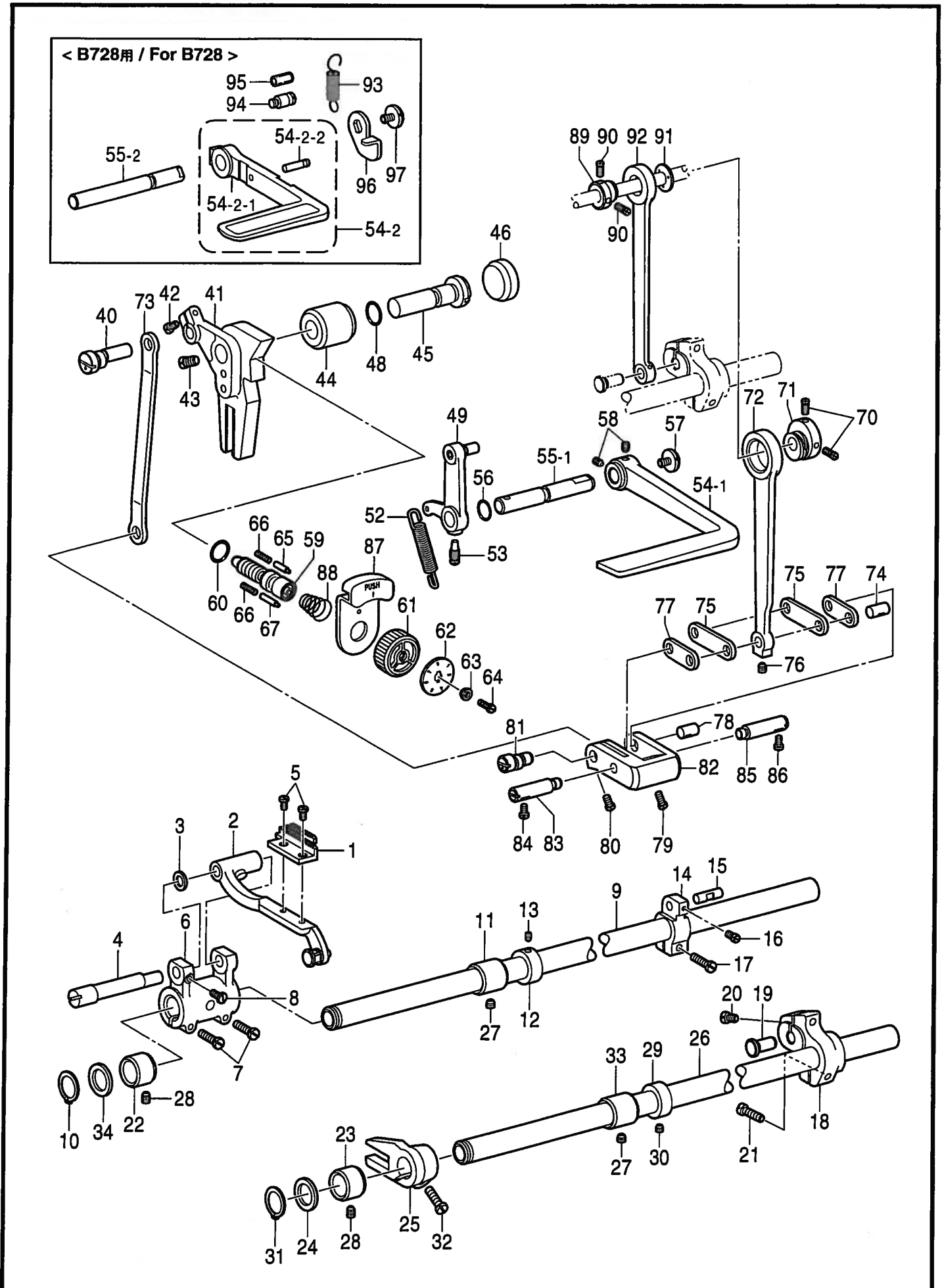

D. 送り関係 / Feed mechanism / Transportvorrichtung / Mécanisme de l'entraînement / Mecanismo de la alimentación

REF.NO.	CODE	Q'TY	ヒンメイ	NAME OF PARTS	RM
56	SW0176001	1	レバージクOリング	O RING	
57	SW0177001	1	<B727用> カエシヌイレバーフタネジ	<For B727> CAP SCREW, SM4.76-28X7	
58	SW0178001	2	カエシヌイレバートメネジ	SET SCREW, SM5.95-28X6.5	
59	SW0179001	1	オクリチヨウセツネジ	ADJUSTING SCREW	
60	SW0180001	1	チヨウセツネジOリング	O RING	
61	SW0181001	1	オクリメモリイタイ	STITCH LENGTH CONTROL DIAL	
62	SW0182001	1	オクリメモリイタ	STITCH LENGTH CONTROL PLATE	
63	SW0183001	1	メモリイタオサエ	SUPPORT PLATE	
64	SW0184001	1	メモリイタオサエシメネジ	SCREW, SM4.76-28X12	
65	SW0185001	1	メモリイチキメピン	POSITIONING PIN	
66	SW0186001	2	メモリイチキメピンバネ	SPRING, COMPRESSION	
67	SW0477001	1	ダイヤルストツバピン	STOPPER PIN, DIAL	
70	SW0190001	2	スイハイヘンシンリントメネジ	SET SCREW, SM4.37-40X11	
71	SW0191001	1	スイハイヘンシンリン	LEVEL FEED ECCENTRIC WHEEL	
72	SW0192001	1	スイハイオクリレンカン	LEVEL FEED CONNECTING ROD	
73	SW0509001	1	キリカエキレンカン	CONNECTING ROD	
74	SW0194001	1	リンクジク	STUD	
75	SW0195001	2	スイハイオクリウデリンク	LINK	
76	SW0135001	1	トメネジ437X40X5	SET SCREW, SM4.37-40X5	
77	SW0197001	2	スイハイオクリリンク	FEED LINK	
78	SW0198001	1	オクリリンクジクR	SHAFT, R	
79	SW0199001	1	キリカエキトメネジ	SCREW, SM3.57-40X8.5	
80	SW0200001	1	オクリリンクジクLトメネジ	SCREW, SM3.57-40X6.5	
81	SW0201001	1	オクリリンクジクL	SHAFT, L	
82	SW0202001	1	キリカエキ	FEED REGULATOR	
83	SW0203001	1	キリカエキジクL	SHAFT, L	
84	SW0136001	1	シメネジ437X40X12	SCREW, SM4.37-40X12	
85	SW0205001	1	キリカエキジクR	SHAFT, R	
86	SW0206001	1	キリカエキジクRトメネジ	SCREW, SM4.37	
87	SW0207001	1	マワリドメ	STOPPER	
88	SW0208001	1	マワリドメバネ	SPRING	
89	SW0290001	1	UDヘンシンリン	ECCENTRIC WHEEL, UD	
90	SW0291001	2	UDヘンシンリントメネジ	SET SCREW, SM4.37-40X11	
91	SW0292001	1	レンカンオサエ	HOLDER	
92	SW0293001	1	UDオクリレンカン	FEED CONECTTING ROD, UD	
93	S02563001	1	<B728用> モドシバネ	<For B728> SPRING	
94	S02562001	1	バネカケ	SPRING HOOK	
95	153132000	1	ナイロンチューブ	NYLON TUBE, L = 13.5	
96	S02578101	1	カエシヌイレバーイタ	REVERSE STITCHING LEVER PLATE	
97	100511003	1	シメネジ4.76	SCREW, SM4.76	

E . 上送り関係 / Upper feed mechanism / Obertransportvorrichtung /
 Mécanisme de l'entraînement supérieur / Mecanismo de la alimentación superior

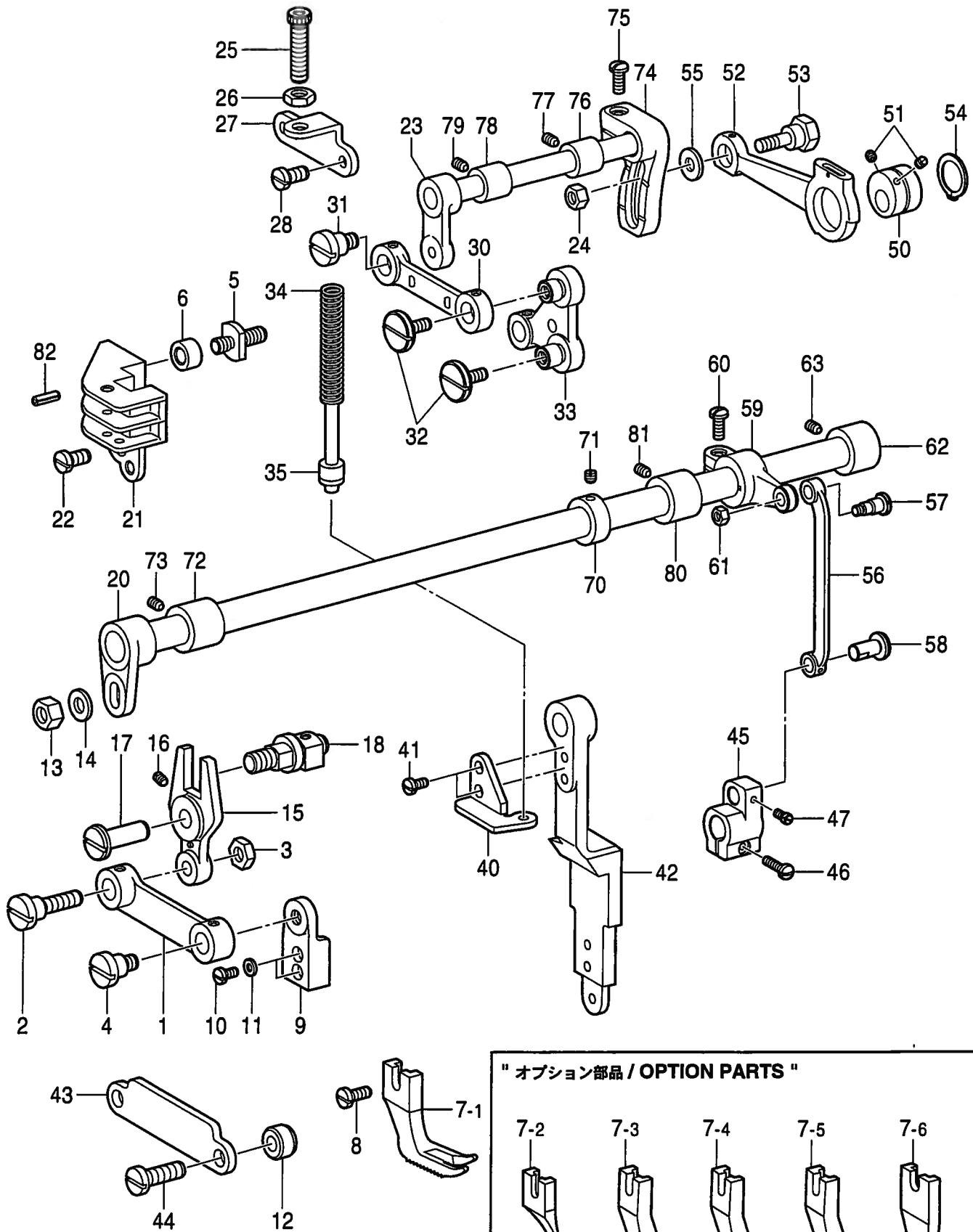

" オプション部品 / OPTION PARTS "

7-2 7-3 7-4 7-5 7-6

E. 上送り関係 / Upper feed mechanism / Obertransportvorrichtung /
 Mécanisme de l'entraînement supérieur / Mecanismo de la alimentación superior

REF.NO.	CODE	Q'TY	ヒンメイ	NAME OF PARTS	RM
1	SW0210001	1	リンクS	LINK, S	
2	SW0211001	1	リンクSダンネジL	SHOULDER SCREW, L	
3	SW0212001	1	リンクSダンネジLナット	NUT, SM6.35	
4	SW0213001	1	リンクダンネジ	SHOULDER SCREW, SM6.35	
5	SW0214001	1	コロジク	ROLLER SHAFT	
6	SW0215001	1	U-UDオクリレバーコロ	ROLLER	
7-1	SW0216001	1	オクリアシ	WALKING FOOT	
8	SW0217001	1	オクリアシトリツケネジ	SCREW, SM3.57-40X8	
9	SW0218001	1	オクリアシレンカンダキ	CLAMPER	
10	SW0219001	2	シメネジ	SCREW, SM3.57-40X7	
11	SW0220001	2	レンカンダキザガネ	WASHER, PLAIN	
12	SW0221001	2	カラー	COLLAR	
13	SW0222001	1	1シユナット	NUT, 1 SM6.35	
14	SW0223001	1	ワツシヤー	WASHER, PLAIN	
15	SW0224001	1	Uスイハイオクリレバー	LEVER	
16	SW0225001	1	オクリレバートメネジ	SET SCREW, SM4.76-32X7	
17	SW0226001	1	レバージク	SHAFT	
18	SW0227001	1	コロジククミ	ROLLER SHAFT ASSY	
20	SW0230001	1	Uスイハイオクリジククミ	UPPER FEED ROCKER SHAFT ASSY	
21	SW0231001	1	U-UDオクリレバーアンナイ	LEVER GUIDE	
22	SW0232001	2	シメネジ	SCREW, SM4.37-40X8	
23	SW0233001	1	オクリウデLジククミ	FEEDING ARM SHAFT ASSY, L	
24	SW0234001	1	1シユナット	NUT, 1 M6	
25	SW0235001	1	バネチヨウセツネジ	ADJUSTING SCREW	
26	SW0236001	1	ナット	NUT, SM7.14	
27	SW0237001	1	オクリアシオサエバネダイ	BRACKET	
28	SW0232001	2	シメネジ	SCREW, SM4.37-40X8	
30	SW0240001	1	リンクL	LINK, L	
31	SW0213001	1	リンクダンネジ	SHOULDER SCREW, SM6.35	
32	SW0242001	2	オクリレバーダンネジ	SHOULDER SCREW, SM4.76	
33	SW0243001	1	U-UDオクリレバー	FEED LEVER	
34	SW0244001	1	オクリアシオサエバネ	SPRING, COMPRESSION	
35	SW0245001	1	オサエバネオシボウ	PUSHER BAR	
40	SW0250001	1	オサエバネウケイタ	HOLDER PLATE	
41	SW0219001	2	シメネジ	SCREW, SM3.57-40X7	
42	SW0251001	1	オクリアシレンカン	CONNECTING ROD	
43	SW0252001	1	オクリアシレンカンアンナイ	ROD GUIDE	
44	SW0136001	2	シメネジ437X40X12	SCREW, SM4.37-40X12	
45	SW0254001	1	スイハイオクリウデUDヨウ	FEED ROCKER ARM, UD	
46	SW0126001	1	シメネジ476X28X15	SCREW, SM4.76-28X15	
47	SW0135001	1	トメネジ437X40X5	SET SCREW, SM4.37-40X5	
50	SW0260001	1	U-UDオクリヘンシンリン	ECCENTRIC WHEEL, U-UD	
51	SW0261001	2	オクリヘンシンリントメネジ	SET SCREW, SM6.35-40X6	
52	SW0262001	1	U-UDオクリレンカン	CONNECTING ROD, U-UD	
53	SW0263001	1	オクリレンカンダンネジ	SHOULDER SCREW, M6	
54	SW0264001	1	Cガタトメワ	RETAINING RING, C	
55	SW0265001	1	オクリレンカンザガネ	WASHER, PLAIN	
56	SW0266001	1	UスイハイオクリレンカンL	CONNECTING ROD, LL	
57	SW0267001	1	オクリレンカンLダンネジ	SHOULDER SCREW, SM7.14	
58	SW0268001	1	スイハイオクリレンカンジク	STUD	
59	SW0269001	1	UスイハイオクリウデR	ARM, R	
60	SW0270001	1	オクリウデRシメネジ	SCREW, SM6.35-24X17	
61	SW0236001	1	ナット	NUT, SM7.14	
62	SW0271001	1	Uスイハイオクリジクメタル	BUSH	
63	SW0041001	1	トメネジ595X28X5	SET SCREW, SM5.95-28X5	
70	SW0012001	1	セツトカラー	SET SCREW COLLAR	
71	SW0013001	2	トメネジ635X40X4	SET SCREW, SM6.35-40X4	
72	SW0282001	1	UスイハイオクリジクメタルL	BUSH, L	
73	SW0041001	1	トメネジ595X28X5	SET SCREW, SM5.95-28X5	

E . 上送り関係 / Upper feed mechanism / Obertransportvorrichtung /
 Mécanisme de l'entraînement supérieur / Mecanismo de la alimentación superior

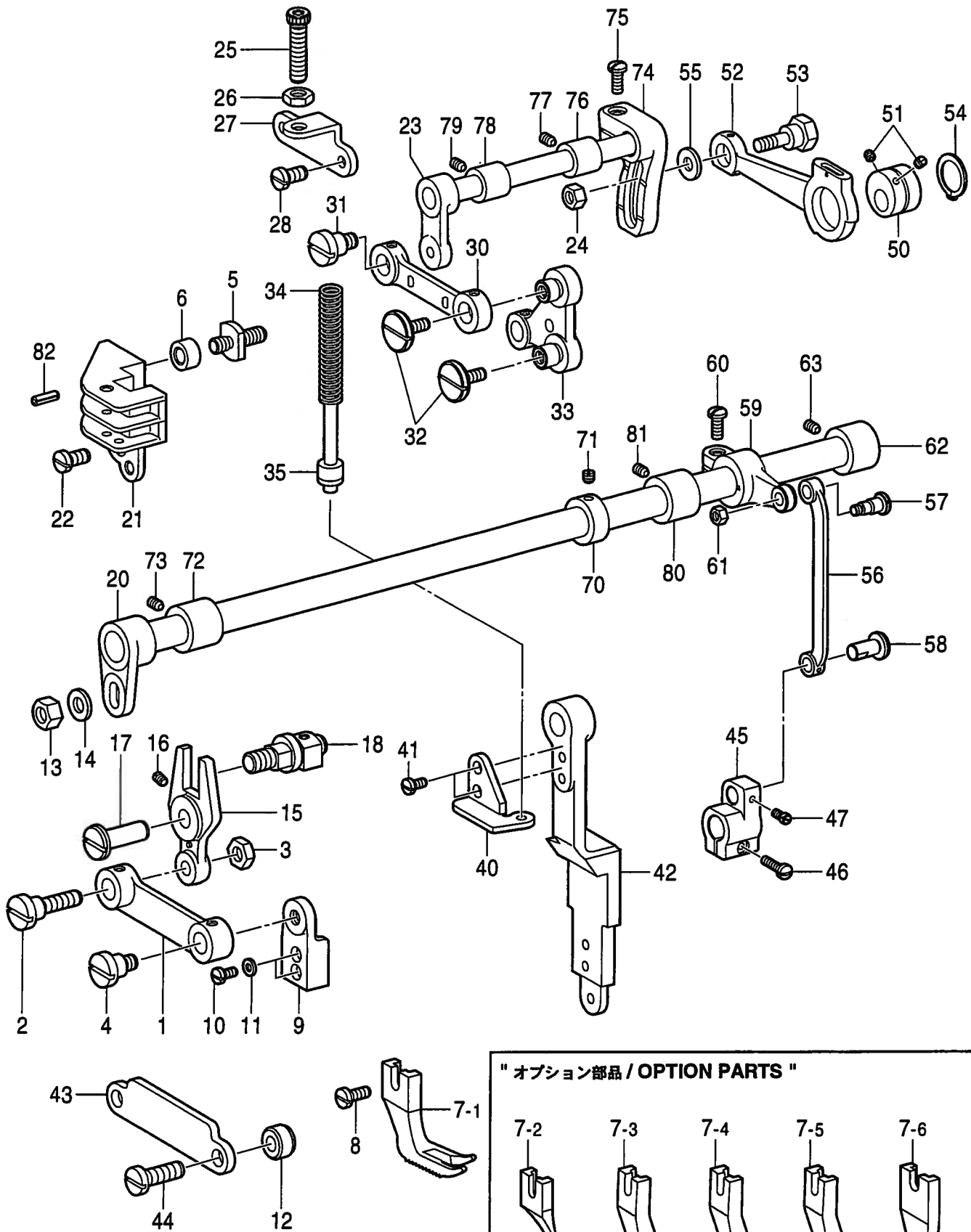

" オプション部品 / OPTION PARTS "

7-2	7-3	7-4	7-5	7-6

From the library of: Diamond Needle Corp

E. 上送り関係 / Upper feed mechanism / Obertransportvorrichtung /
 Mécanisme de l'entraînement supérieur / Mecanismo de la alimentación superior

REF.NO.	CODE	Q'TY	ヒンメイ	NAME OF PARTS	RM
74	SW0283001	1	U-UDオクリウデR	FEED ARM, R	
75	SW0270001	1	オクリウデRシメネジ	SCREW, SM6.35-24X17	
76	SW0284001	1	ウワオクリメタル	BUSH	
77	SW0041001	1	トメネジ595X28X5	SET SCREW, SM5.95-28X5	
78	SW0498001	1	ウワオクリメタルL	BUSH, L	
79	SW0041001	1	トメネジ595X28X5	SET SCREW, SM5.95-28X5	
80	SW0466001	1	UスイハイオクリジクメタルM	BUSH, M	
81	SW0041001	1	トメネジ595X28X5	SET SCREW, SM5.95-28X5	
82	SW0497001	1	スプリングピンAW3	PIN, SPRING AW3	
7-2	S04501001	1	" オプション部品 "	" OPTION PARTS "	
7-3	151847001	1	オクリアシR	WALKING FOOT, R	
7-4	151848001	1	バツカットオサエ KC	WALKING FOOT, KC-1/4	
7-5	151849001	1	バツカットオサエ MC	WALKING FOOT, MC-5/16	
7-6	151851001	1	バツカットオサエ NC	WALKING FOOT, NC-3/8	
			コモノヌイヨウオサエ ソト	WALKING FOOT	

F. カマ関係 / Rotary hook mechanism / Greifervorrichtung / Mécanisme du crochet rotatif / Mecanismo del cangrejo

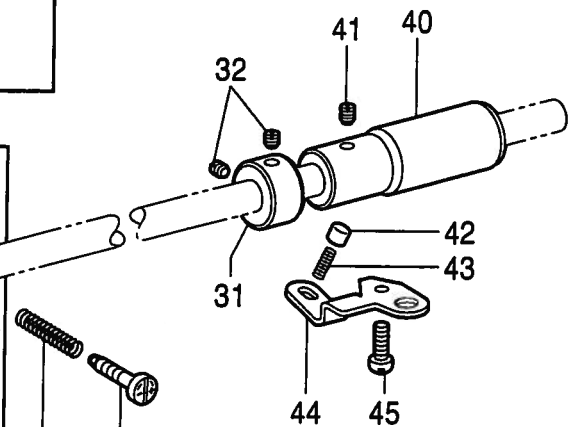
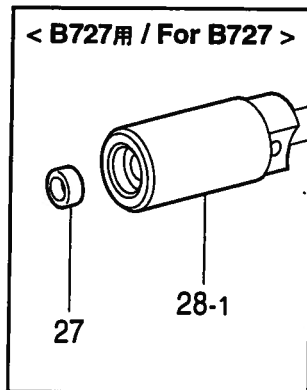
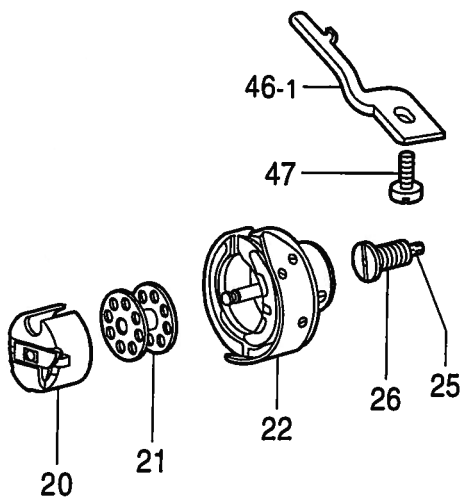
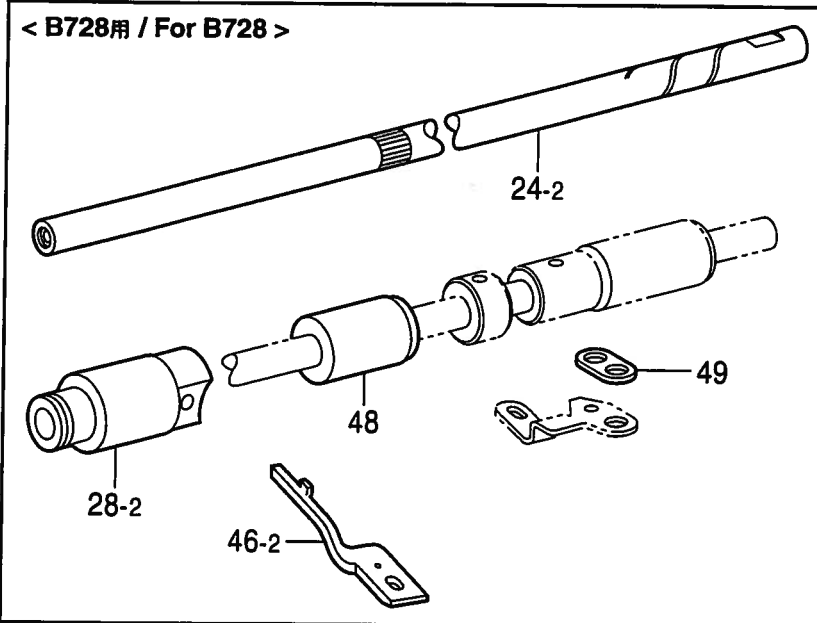
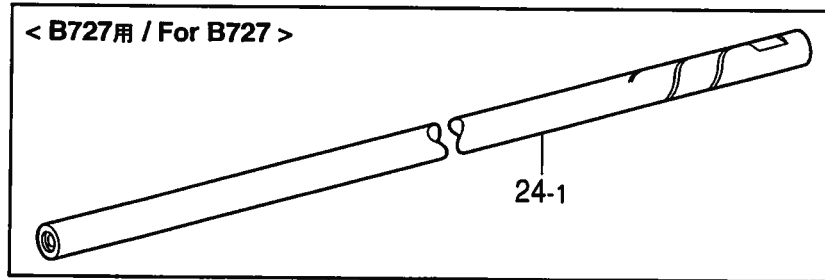
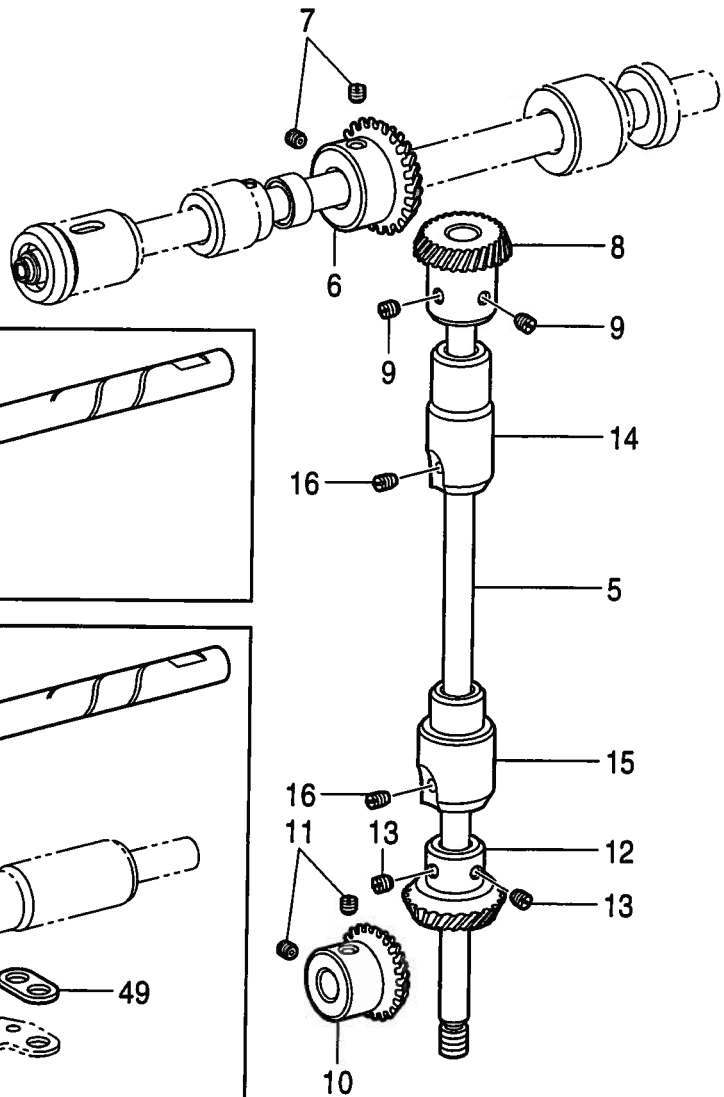

F. カマ関係 / Rotary hook mechanism / Greifervorrichtung / Mécanisme du crochet rotatif / Mecanismo del cangrejo

REF.NO.	CODE	Q'TY	ヒンメイ	NAME OF PARTS	RM
5	SW0294001	1	タテジク	VERTICAL SHAFT	
6	SW0295001	1	ウワジクベベルギヤ	BEVEL GEAR	
7	SW0033001	2	トメネジ635X40X7	SET SCREW, SM6.35-40X7	
8	SW0297001	1	タテジクベベルギヤU	BEVEL GEAR, U	
9	SW0033001	2	トメネジ635X40X7	SET SCREW, SM6.35-40X7	
10	SW0298001	1	シタジクベベルギヤ	BEVEL GEAR	
11	SW0033001	2	トメネジ635X40X7	SET SCREW, SM6.35-40X7	
12	SW0299001	1	タテジクベベルギヤD	BEVEL GEAR, D	
13	SW0033001	2	トメネジ635X40X7	SET SCREW, SM6.35-40X7	
14	SW0300001	1	タテジクメタルU	BUSH, U	
16	SW0016001	2	トメネジ595X28X10	SET SCREW, SM5.95-28X10	

15	SW0301001	1	<B727用> タテジクメタルD	<For B727> BUSH, D	
20	SW0310001	1	ボビンケースクミ	BOBBIN CASE ASSY	
21	SW0311001	1	ボビン	BOBBIN	
22	SW0312901	1	コウソクカマハコクミ	ROTARY HOOK ASSY, W/BOX	
24-1	SW0314001	1	シタジク	LOWER SHAFT	
27	SW0317001	1	シタジクオイルシール	OIL SEAL	
28-1	SW0318001	1	シタジクメタルL	BUSH, L	

15	SW0520001	1	<B728用> タテジクメタルD	<For B728> BUSH, D	
20	151845001	1	ボビンケースクミ	BOBBIN CASE ASSY	
21	SW0521001	1	ボビン	BOBBIN	
22	159793901	1	コウソクカマB1ハコクミ	ROTARY HOOK ASSY, B1 W/BOX	
24-2	SW0518001	1	シタジク	LOWER SHAFT	
28-2	SW0545001	1	シタジクメタルL	BUSH, L	

25	SW0315001	1	フィルター	FILTER	
26	SW0316001	1	フィルターセンネジ	CAP SCREW, SM4.76	
29	SW0319001	1	オイルチヨウセツネジ	ADJUSTING SCREW	
30	SW0320001	1	オイルチヨウセツネジバネ	SPRING	
31	SW0321001	1	セツトカラー	SET SCREW COLLAR	
32	SW0041001	2	トメネジ595X28X5	SET SCREW, SM5.95-28X5	
40	SW0330001	1	シタジクメタルR	BUSH, R	
41	SW0079001	1	トメネジ595X28X8	SET SCREW, SM5.95-28X8	
42	SW0332001	1	プランジャー	PLUNGER	
43	SW0333001	1	プランジャーバネ	SPRING, COMPRESSION	
44	SW0334001	1	プランジャーウケイタ	HOLDER PLATE	
45	SW0335001	1	シメネジ	SCREW, SM4.37-40X13	
47	SW0079001	1	トメネジ595X28X8	SET SCREW, SM5.95-28X8	

46-1	SW0336001	1	<B727用> ウチカマトメ	<For B727> B-CASE HOLDER POSITION BRACKET	

46-2	147337001	1	<B728用> ウチカマトメ	<For B728> B-CASE HOLDER POSITION BRACKET	
48	S31027020	1	シタジクメタルM	LOWER SHAFT BUSH, M	
49	SW0525001	1	プランジャーウケイタ	HOLDER PLATE	

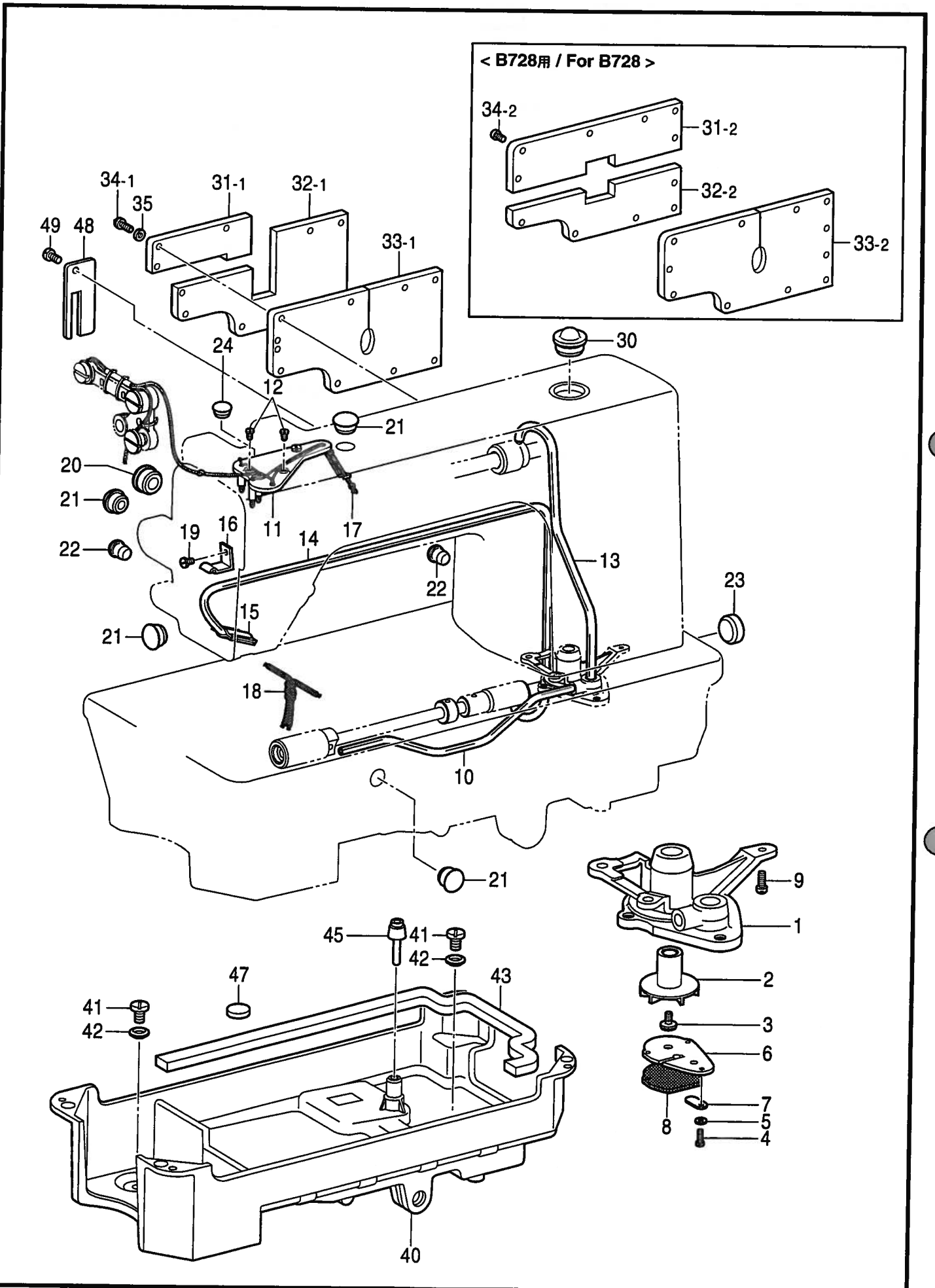

G. 給油潤滑関係 / Lubrication / Schmierung / Lubrification / Lubricación

REF.NO.	CODE	Q'TY	ヒンメイ	NAME OF PARTS	RM
1	SW0350001	1	ポンプタイ	PUMP BODY	
2	SW0351001	1	ポンプカイテンヨク	PUMP PROPELLER	
3	SW0352001	1	カイテンヨクシメネジ	SCREW, SM3.18-44X6.5	
4	SW0353001	3	シボリyataトメネジ	SCREW, SM3.18-44X13	
5	SW0354001	1	ワツシヤ-	WASHER, PLAIN	
6	SW0355001	1	カイテンヨクフタ	COVER	
7	SW0356001	1	リュウリヨウシボリyata	THROTTLE PLATE	
8	SW0357001	1	ポンプフィルターセット	FILTER SET	
9	SW0335001	3	シメネジ	SCREW, SM4.37-40X13	
<hr/>					
10	SW0359001	1	<B727用> オイルチューブD	<For B727> OILTUBE, D	
10	SW0524001	1	<B728用> オイルチューブD	<For B728> OIL TUBE, D	
<hr/>					
11	SW0360001	1	アブラヒモトリツケイタ	SETTING PLATE	
12	SW0361001	2	トリツケイタシメネジ	SCREW, SM3.57-40X11	
13	SW0362001	1	オイルチューブU	OIL TUBE, U	
14	SW0363001	1	チューブクミ	TUBE ASSY	
15	SW0364001	1	フェルトオサエ	FELT SUPPORT	
16	SW0365001	1	チューブクミササエ	SUPPORTER	
17	SW0366001	1	キウウユヒモ	OIL WICK	
18	SW0367001	1	オクリジククミヒモ	OIL WICK	
19	SW0086001	1	シメネジ437X40X6	SCREW, SM4.37-40X6	
20	SW0370001	1	ゴムセン	RUBBER CAP	
21	SW0371001	4	ゴムセン	RUBBER CAP	
22	SW0372001	2	ゴムセン	RUBBER CAP	
23	SW0373001	1	ゴムセン	RUBBER CAP	
24	SW0374001	1	ゴムセン	RUBBER CAP	
30	SW0380001	1	ユリヨウケイマド	OIL GAUGE WINDOW	
<hr/>					
31-1	SW0381001	1	<B727用> ガワイタS	<For B727> REAR COVER, S	
32-1	SW0382001	1	ガワイタL	REAR COVER, L	
33-1	SW0383001	1	ガワイタパツキング	PACKING	
34-1	SW0384001	10	ガワイタシメネジ	SCREW, SM4.37-40X9	
35	SW0385001	10	ガワイタシメネジワツシヤ-	WASHER, PLAIN	
40	SW0390001	1	オイルパン	OIL PAN	
<hr/>					
31-2	SW0522001	1	<B728用> ガワイタU	<For B728> REAR COVER, U	
32-2	SW0523001	1	ガワイタL	REAR COVER, L	
33-2	SW0544001	1	ガワイタパツキング	PACKING	
34-2	062681012	11	ナベコ437-40X10	SCREW, PAN SM4.37-40X10	
40	SW0543001	1	オイルパン	OIL PAN	
<hr/>					
41	SW0391001	2	アブラヌキネジ	SCREW, SM7.94-28X10	
42	SW0392001	2	アブラヌキリング	RING	
43	S54799000	1	オイルパンパツキン	PACKING, OIL PAN	
45	SW0395001	1	ヒザアゲオシボウ	LIFTER BAR, ;KNEE	
47	SW0397001	1	ジシヤク	MAGNET	
48	SW0490001	1	オイルシヤヘイカバーS	COVER, S	
49	SW0491001	1	カバーシメネジ	SCREW, SM4.37-40X6	

H. 糸通シ関係 / Threading mechanism / Fadenführungsrichtung / Mécanisme de l'enfilage / Mecanismo del enhebrado

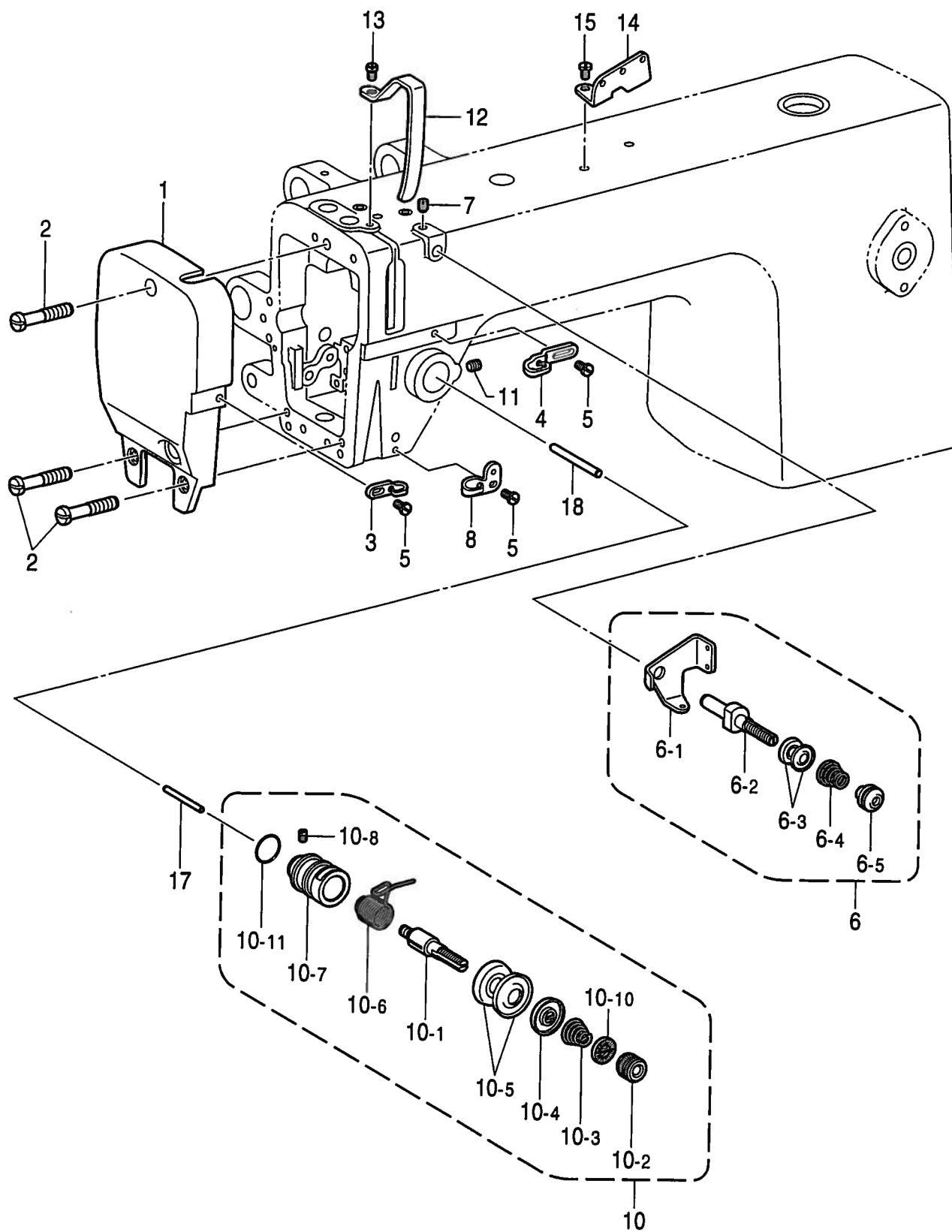

H. 糸通シ関係 / Threading mechanism / Fadenführungsrichtung / Mécanisme de l'enfilage / Mecanismo del enhebrado

REF.NO.	CODE	Q'TY	ヒンメイ	NAME OF PARTS	RM
1	SW0410001	1	メンイタ	FACE PLATE	
2	SW0411001	3	メンイタシメネジ	SCREW, SM4.37-40X20	
3	SW0412001	1	アームイトアンナイ	THREAD GUIDE	
4	SW0413001	1	アームイトアンナイD	THREAD GUIDE, D	
5	SW0414001	3	アームイトアンナイトメネジ	SCREW, SM3.57-40X6	

6	SW0415001	1	<B727用> イトアンナイクミ	<For B727> THREAD GUIDE ASSY	
6-1	SW0416001	1	イトアンナイ	THREAD GUIDE	
6-2	SW0417001	1	イトアンナイチヨウシボウ	PRE-TENSION STUD	
6-3	SW0418001	2	イトアンナイサラ	DISC, THREAD GUIDE	
6-4	SW0419001	1	プレテンションバネ	SPRING	
6-5	SW0420001	1	イトアンナイチヨウシネジ	ADJUSTING SCREW	

6	SW0546001	1	<B728用> イトアンナイクミ	<For B728> THREAD GUIDE ASSY	
6-1	SW0416001	1	イトアンナイ	THREAD GUIDE	
6-2	SW0417001	1	イトアンナイチヨウシボウ	PRE-TENSION STUD	
6-3	SW0418001	2	イトアンナイサラ	DISC, THREAD GUIDE	
6-4	154560001	1	プレテンションバネA	SPRING,A	
6-5	SW0420001	1	イトアンナイチヨウシネジ	ADJUSTING SCREW	

7	SW0421001	1	イトアンナイクミトリツケネジ	SET SCREW, SM4.37-40X5.5	
8	SW0492001	1	アームイトアンナイB	THREAD GUIDE, B	
10	SW0430001	1	イトチヨウシボウクミ	THREAD TENSION BRACKET ASSY	
10-1	SW0431001	1	イトチヨウシボウ	TENSION STUD	
10-2	SW0432001	1	イトチヨウシナツト	TENSION NUT	
10-3	SW0433001	1	イトチヨウシバネ	TENSION SPRING	
10-4	SW0434001	1	イトチヨウシサラオサエ	DISC PRESSER	
10-5	SW0435001	2	イトチヨウシサラ	DISC, TENSION	
10-6	SW0436001	1	イトトリバネ	THREAD TAKE-UP SPRING	
10-7	SW0437001	1	イトチヨウシボウダイ	THREAD TENSION BRACKET	
10-8	SW0438001	1	イトチヨウシボウトメネジ	SET SCREW, SM3.57-40X6	
10-10	SW0440001	1	ローレットストツバ	STOPPER	
10-11	SW0441001	1	Oリング	O RING	
11	SW0079001	1	トメネジ595X28X8	SET SCREW, SM5.95-28X8	
12	SW0443001	1	テンピンカバー	COVER, ;T/TAKE-UP LEVER	
13	SW0086001	1	シメネジ437X40X6	SCREW, SM4.37-40X6	
14	SW0445001	1	イトカケ	THREAD RETAINER	
15	SW0446001	1	イトカケシメネジ	SCREW, SM4.37-40X8	

17	SW0439001	1	<B727用> イトユルメピン	<For B727> PIN	
18	SW0070001	1	イトユルメジク	SHAFT	

17	SW0526001	1	<B728用> イトユルメピン	<For B728> TENSION RELEASE PIN	
18	SW0527001	1	イトユルメボウ	TENSION RELEASE STUD	

J. 糸切り関係 (B728) / Thread trimmer mechanism (B728) / Fadenabschneidevorrichtung (B728) / Mécanisme de coupe-fil (B728) / Mecanismo de la cortadura de hiros (B728)

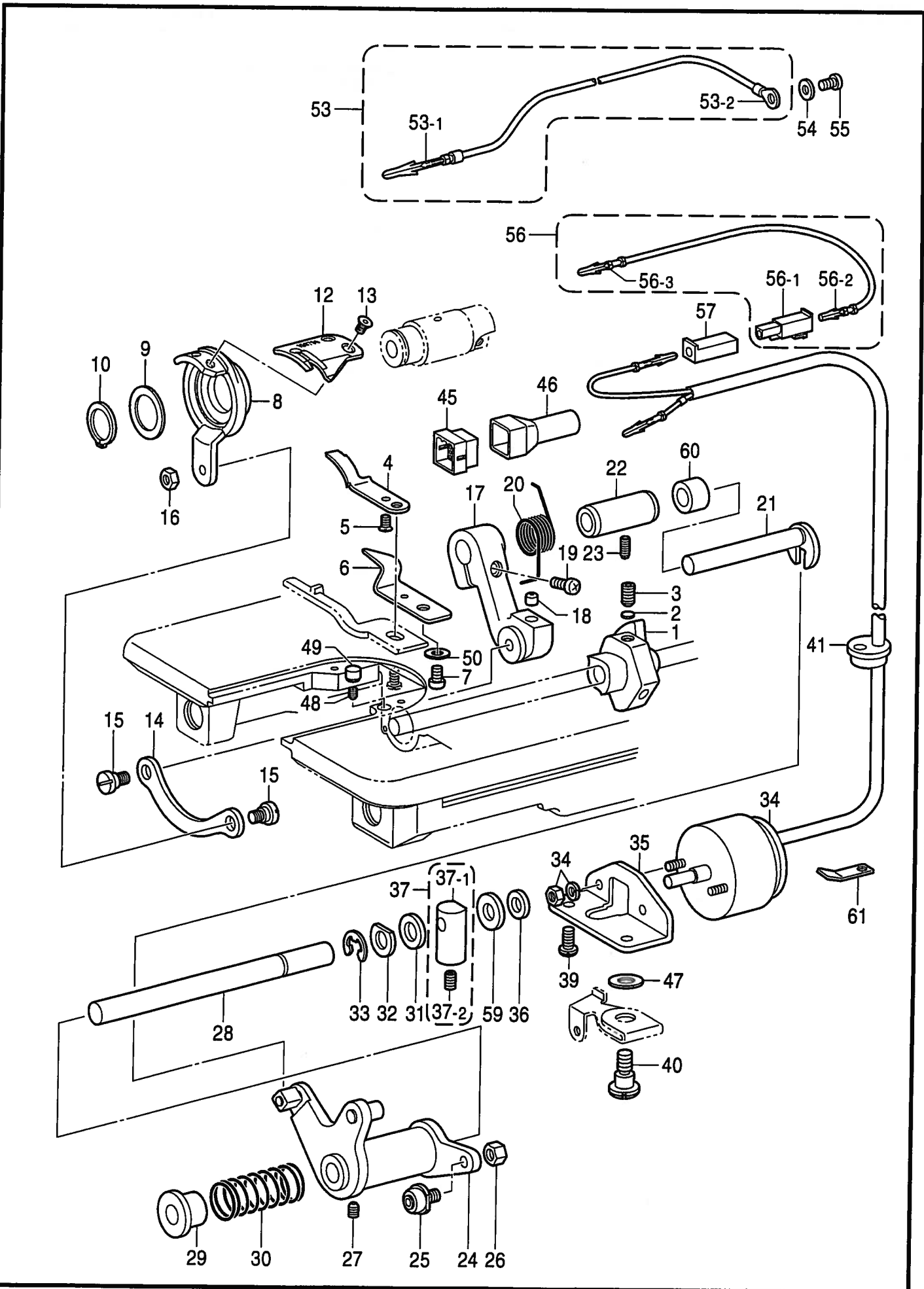

From the library of: Diamond Needle Corp

J. 糸切り関係 (B728) / Thread trimmer mechanism (B728) / Fadenabschneidevorrichtung (B728) /
 Mécanisme de coupe-fil (B728) / Mecanismo de la cortadura de hiros (B728)

REF.NO.	CODE	Q'TY	ヒンメイ	NAME OF PARTS	RM
1	S00337021	1	イトキリカム	THREAD TRIMMER CAM	
2	154567000	2	カンザ5.3	SPACER, 5.3	
3	014771022	2	アナトメネジ6.35クボミ	SET SCREW, SOCKET (CP) SM6.35	
4	154568101	1	コテイハ	FIXED KNIFE	
5	102843004	1	サラネジ3.57	SCREW, FLAT SM3.57	
6	159797001	1	イトサバキ	LOWER THREAD FINGER	
7	062680712	1	ナベコ437-40X7	SCREW, PAN SM4.37-40X7	
8	159798001	1	イトキリホルダ	HOLDER, M-KNIFE	
9	156620000	1	スラストザガネ	WASHER, THRUST	
10	048180142	1	トメワジクヨウC18	RETAINING RING, EXTERNAL C18	
12	159799001	1	イドウハ	MOVABLE KNIFE	
13	148537101	2	サラネジ4.37	SCREW, FLAT (W/SOCKET) SM4.37	
14	154576003	1	イトキリレンカン	THREAD TRIMMER CONNECTING ROD	
15	151987002	2	ダンネジ4.37	SHOULDER, SCREW SM4.37	
16	102571003	1	ナツト4.37	NUT, SM4.37	
17	S01486001	1	イトキリレバー	THREAD TRIMMER LEVER	
18	S25437000	1	レバーストツバ	STOPPER, LEVER	
19	062711412	1	ナベコ4.76-32X14	SCREW, PAN SM4.76-32X14	
20	154579001	1	イトキリレバーバネ	SPRING	
21	S02647001	1	フタマタジク	FORKED SHAFT	
22	154581001	1	フタマタジクメタル	BUSH, FORKED SHAFT	
23	151607001	1	トメネジ4.37	SET SCREW, SM4.37	
24	154582021	1	イトキリカムレバークミ	THREAD TRIMMER CAM LEVER ASSY	
25	154590001	1	コロジクCクミ	ROLLER SHAFT ASSY, C	
26	105234003	1	ナツト4.37	NUT, SM4.37	
27	014770622	1	アナトメネジ6.35クボミ	SET SCREW, SOCKET (CP) SM6.35	
28	154593201	1	イトキリカムレバークミ	THREAD TRIMMER CAM LEVER SHAFT	
29	154594000	1	カラー	COLLAR	
30	154595001	1	カムレバーモドシバネ	SPRING	
31	154596000	1	イトキリカムレバークツシヨン	CUSHION	
32	110367001	1	ザガネ	WASHER, PLAIN SPECIAL 8	
33	048060342	1	トメワE6	RETAINING RING, E6	
34	S02815009	1	イトキリソレノイド	THREAD TRIMMER SOLENOID	
35	SW0528001	1	イトキリソレノイドダイ	THREAD TRIMMER SOLENOID BASE	
36	154599000	1	ソレノイドクツシヨン	CUSHION, ;SOLENOID	
37	S23836001	1	ソレノイドレバークミ	SOLENOID LEVER ASSY	
37-1	S02654001	1	ソレノイドレバー	SOLENOID LEVER	
37-2	014680622	1	アナトメネジ4.37クボミ	SET SCREW, SOCKET (CP) SM4.37	
39	110201001	1	シメネジ6.35	SCREW, SM6.35	
40	S02655002	1	ダンネジ6.35	SHOULDER SCREW, SM6.35	
41	146020009	1	コードブシュ	CORD BUSH	
45	153969000	1	ナイロンコネクタ12P	NYLON CONNECTOR, 12P	
46	S03815001	1	コネクタキャップ6	CONNECTOR CAP, 6	
47	155559001	1	ヒラザガネ	WASHER, PLAIN	
48	013660612	1	トメネジ3.18クボミ	SET SCREW, (CP) SM3.18	
49	142274009	1	ゴムセン4.2	RUBBER CAP, 4.2	
50	100645003	1	ザガネ	WASHER	
53	S02682001	1	アースセンクミ	GROUND WIRE ASSY	
53-1	S03328000	1	ピンターミナルオスL	TERMINAL PIN, L ;MALE	
53-2	204569001	1	アツタンシ4.5X14	TERMINAL, 4.5X14	
54	S02745001	1	ザガネ	WASHER	
55	062680663	1	ナベコ437-40X6	SCREW, PAN SM4.37-40X6	
56	S11210000	1	WコードSクミ	W-CORD ASSY, S	
56-1	S11684000	1	コネクタ3191-01R1	CONNECTOR, 3191-01R1	
56-2	143548000	1	ピンターミナルメス	TERMINAL PIN, ;FEMALE	
56-3	143549000	1	ピンターミナルオス	TERMINAL PIN, ;MALE	
57	S11683000	1	コネクタ3191-01P1	CONNECTOR, 3191-01P1	
59	S02652001	1	ザガネ	WASHER	
60	S02648001	1	カラー	COLLAR	
61	S02657101	1	コードオサエ	CORD HOLDER	

K . 逆転関係 (B728) / Quick reverse mechanism (B728) / Umkehr (B728) /
 Mécanisme de marche arrière rapide (B728) / Mecanismo de la inversión rápida (B728)

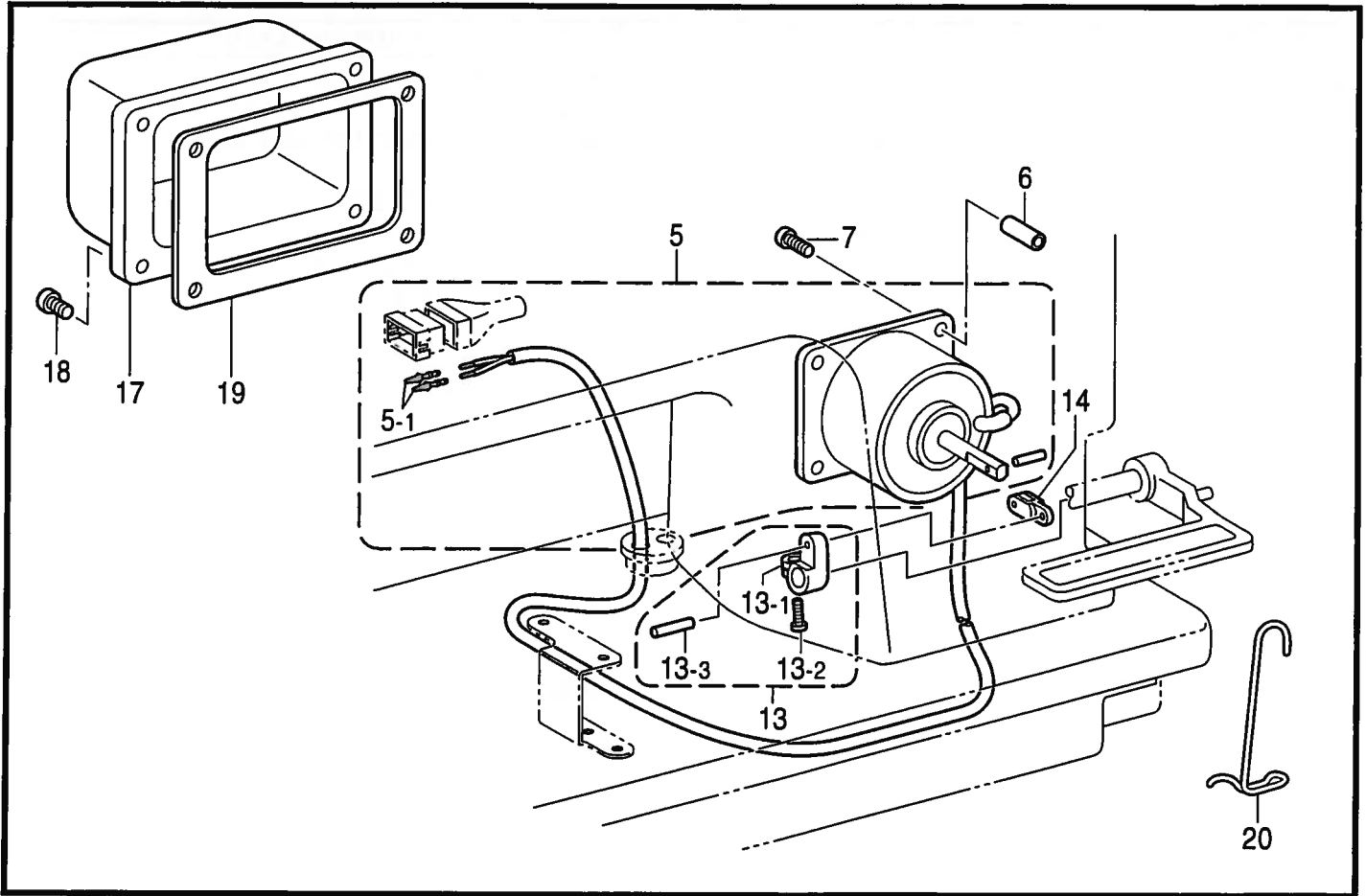

117-727-205

L . 糸緩メ関係 (B728) / Tension release mechanism (B728) / Spannungsverminderrungsvorrichtung (B728) /
 Mécanisme de la lâche de tension (B728) / Mecanismo relajador de tensión (B728)

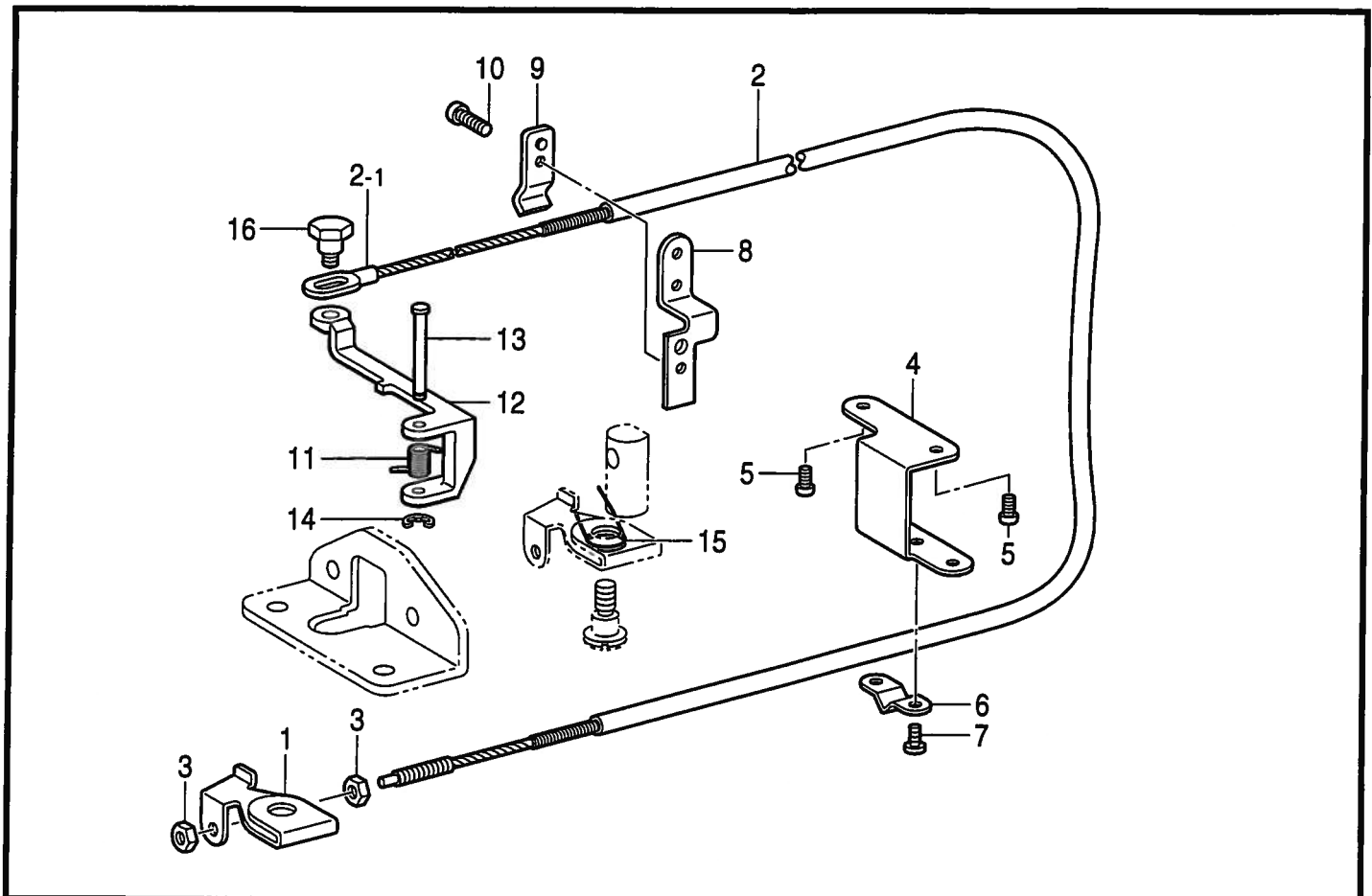

117-727-404

K. 逆転関係 (B728) / Quick reverse mechanism (B728) / Umkehr (B728) /

Mécanisme de marche arrière rapide (B728) / Mecanismo de la inversión rápida (B728)

REF.NO.	CODE	Q'TY	ヒンメイ	NAME OF PARTS	RM
5	S54796001	1	ギヤクテンソレノイドクミ	QUICK REVERSE SOLENOID ASSY	
5-1	143549000	2	ピンターミナルオス	TERMINAL PIN, ;MALE	
6	SW0510001	4	スパーサカラー	SPACER COLLAR	
7	SW0511001	4	ナベコ476-32X25	SCREW, PAN SM4.76-32X25	
13-1	SW0514001	1	ソレノイドレバー	SOLENOID LEVER	
13-2	062711412	1	ナベコ4.76-32X14	SCREW, PAN SM4.76-32X14	
13-3	S38670001	1	ニードルローラー4X13.8	NEEDLE ROLLAR, 4X13.8	
14	SW0512001	1	レンゲツリンク	CONNECTING LINK	
17	SW0515001	1	ソレノイドカバー	SOLENOID COVER	
18	062681012	4	ナベコ437-40X10	SCREW, PAN SM4.37-40X10	
19	SW0516000	1	ソレノイドカバーパツキン	PACKING, S-COVER	
20	SW0517001	1	コードオサエ	CORD HOLDER	

117-727-205

L. 糸緩メ関係 (B728) / Tension release mechanism (B728) / Spannungsverminderungsrichtung (B728) /

Mécanisme de la lâche de tension (B728) / Mecanismo relajador de tensión (B728)

REF.NO.	CODE	Q'TY	ヒンメイ	NAME OF PARTS	RM
1	SW0529001	1	イトユルメレバー	TENSION RELEASE LEVER	
2	SW0530001	1	イトユルメワイヤー	TENSION RELEASE WIRE	
2-1	S01510001	1	ワイヤージョイント	WIRE JOINT	
3	110161004	2	ナツト4.76	NUT, SM4.76	
4	154606021	1	イトユルメワイヤーホルダD	WIRE HOLDER, D	
5	062670812	2	ナベコ3.57-40X8	SCREW, PAN SM3.57-40X8	
6	154607121	1	イトユルメワイヤーオサエD	WIRE HOLDER, D	
7	060670612	2	バインド357-40X6	SCREW, BIND SM3.57-40X6	
8	SW0531001	1	イトユルメワイヤーホルダU	WIRE HOLDER, U	
9	149133101	1	イトユルメワイヤーオサエD	WIRE HOLDER, D	
10	062671612	2	ナベコ357-40X16	SCREW, PAN SM3.57-40X16	
11	SW0532001	1	イトユルメイタモドシバネ	SPRING	
12	SW0533001	1	イトユルメイタ	TENSION RELEASE PLATE	
13	S01507001	1	イトユルメジク	TENSION RELEASE STUD	
14	048020342	1	トメワE2	RETAINING RING, E2	
15	S03670101	1	イトユルメモドシバネ	SPRING	
16	159113001	1	ダンネジ3.18	SHOULDER SCREW, SM3.18	

117-727-404

M. 針位置検出器関係 (B728) / Synchronizer (B728) / Synchronisator (B728) /
Synchronisateur (B728) / Sincronizador (B728)

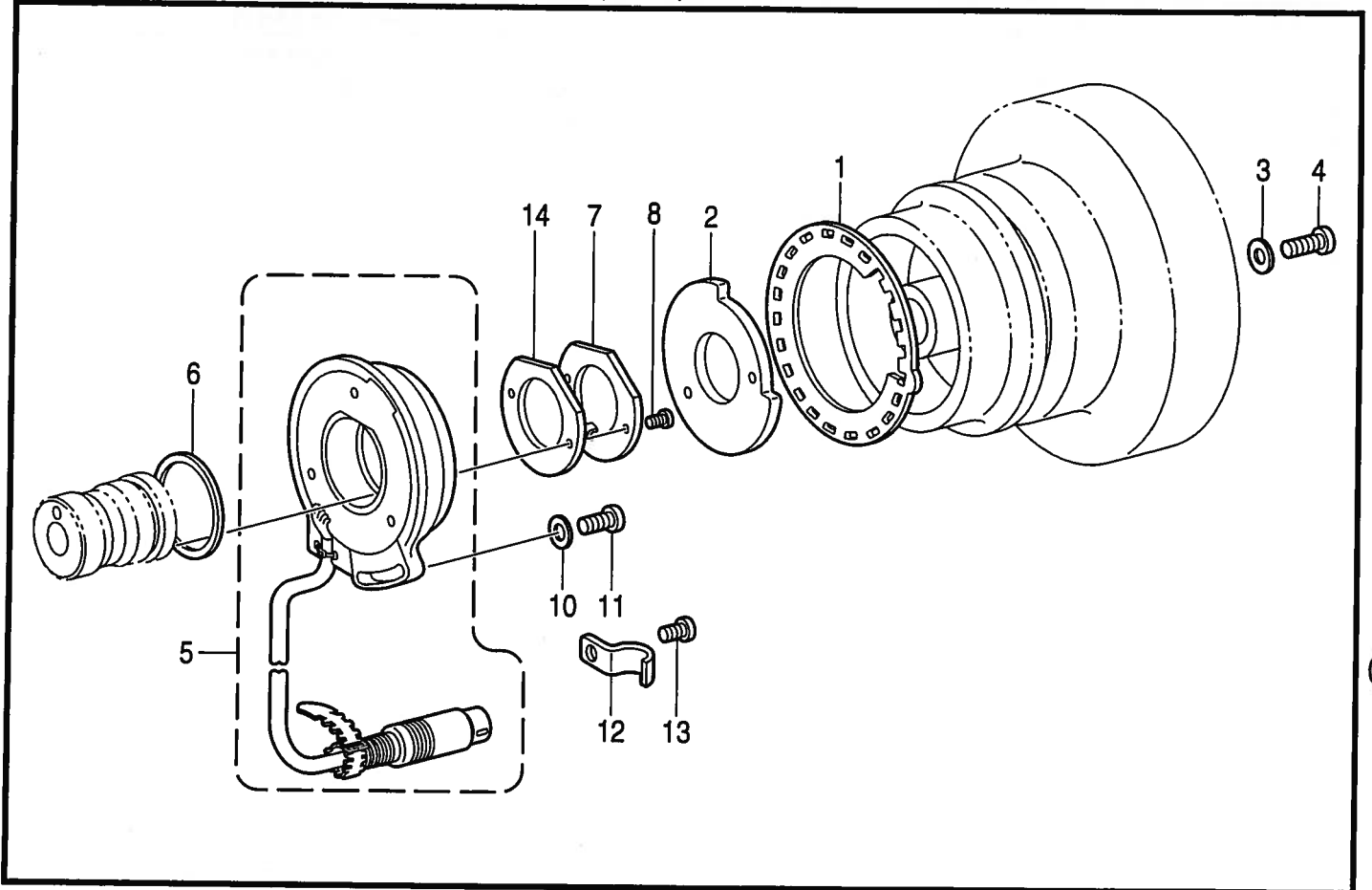

117-727-501

N. 逆転スイッチ関係 (B728) / Quick reverse switch mechanism (B728) / Umkehrschalter (B728) /
Mécanisme de interrupteur de marche arrière rapide (B728) /
Mecanismo del conmutador de inversión rápida (B728)

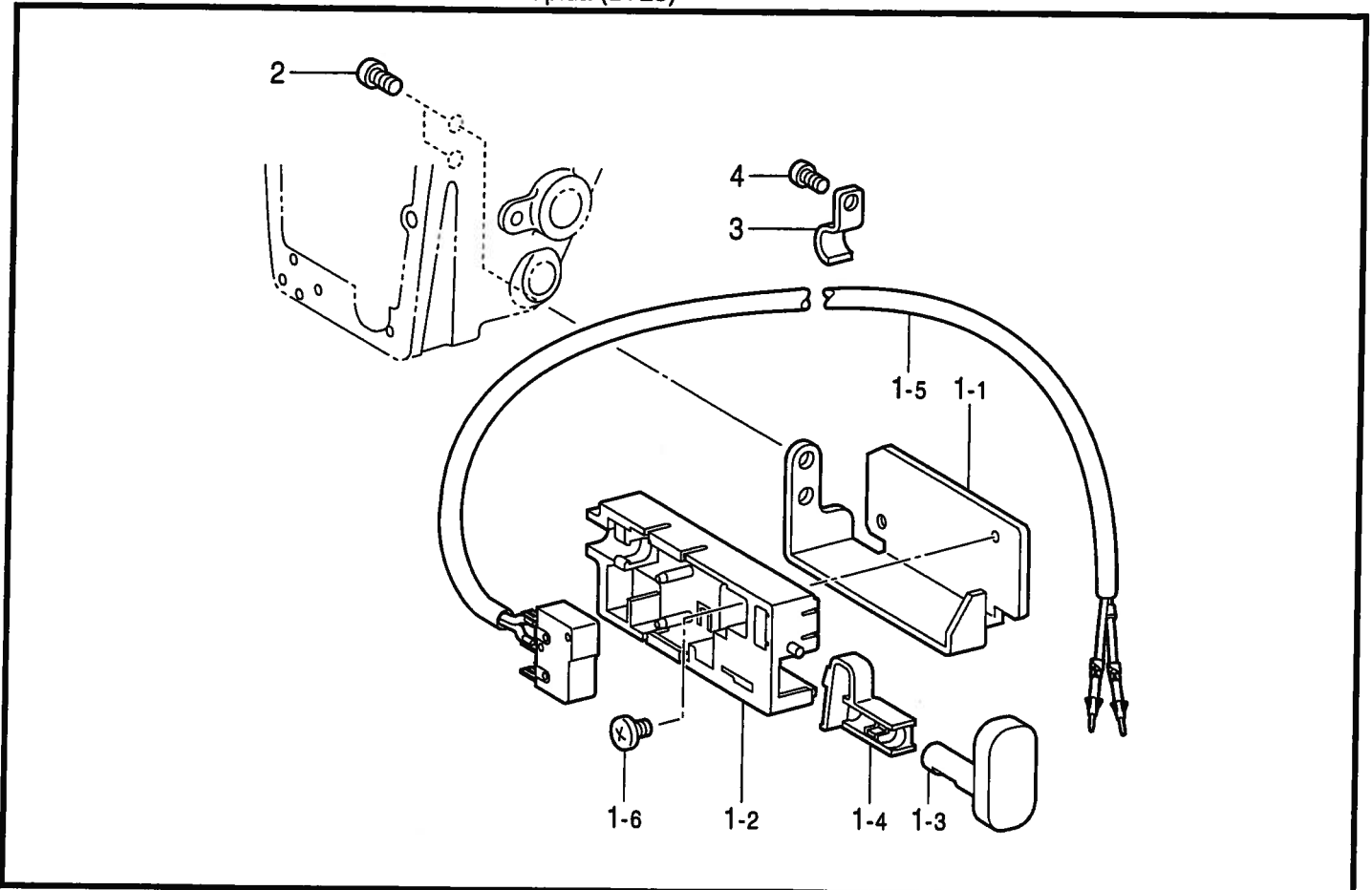

117-727-508

M. 針位置検出器関係 (B728) / Synchronizer (B728) / Synchronisator (B728) /
Synchronisateur (B728) / Sincronizador (B728)

REF.NO.	CODE	Q'TY	ヒンメイ	NAME OF PARTS	RM
1	S02684101	1	ソクドシレイイタ24	SPEED COMMAND PLATE, 24	
2	S02685001	1	ハリウエイタ	PLATE, NEEDLE UPPER STOP	
3	100645003	2	ザガネ	WASHER	
4	062681612	2	ナベコ437-40X16	SCREW, PAN SM4.37-40X16	
5	J80818001	1	シンクロナイザ#18-2X	SYNCHRONIZER, #18-2 X	
6	S03327020	1	シンクロナイザパツキン	PACKING, ;SYNCHRONIZER	
7	S02687221	1	ケンシュツキオサエ	SUPPORT, ;SYNCHRONIZER	
8	062630712	2	ナベコ238-56X7	SCREW, PAN SM2.38-56X7	
10	113431022	1	ザガネ	WASHER	
11	062711012	1	ナベコ476-32X10	SCREW, PAN SM4.76-32X10	
12	140647121	1	コードオサエ	CORD HOLDER	
13	062670612	1	ナベコ357-40X6	SCREW, PAN SM3.57-40X6	
14	S28926020	1	ケンシュツキオサエパツキン	SUPPORT PACKING, SYNCHRONIZER	

117-727-501

N. 逆転スイッチ関係 (B728) / Quick reverse switch mechanism (B728) / Umkehrschalter (B728) /
Mécanisme de interrupteur de marche arrière rapide (B728) /
Mecanismo del conmutador de inversión rápida (B728)

REF.NO.	CODE	Q'TY	ヒンメイ	NAME OF PARTS	RM
1-1	SW0535001	1	Rスイッチササエ	SUPPORT, R-SWITCH	
1-2	SW0536001	1	Rスイッチダイ	BASE, ;R-SWITCH	
1-3	S32904000	1	アクチュエーター	ACTUATOR	
1-4	S32905000	1	Rスイッチバネ	SPRING, ;R-SWITCH	
1-5	S32906000	1	Rスイッチクミ	REVERSE SWITCH ASSY	
1-6	060300606	1	バインド3X6	SCREW, BIND M3X6	
2	062680712	2	ナベコ437-40X7	SCREW, PAN SM4.37-40X7	
3	S02701121	3	コードオサエU1	CORD HOLDER, U1	
4	062670612	3	ナベコ357-40X6	SCREW, PAN SM3.57-40X6	

117-727-508

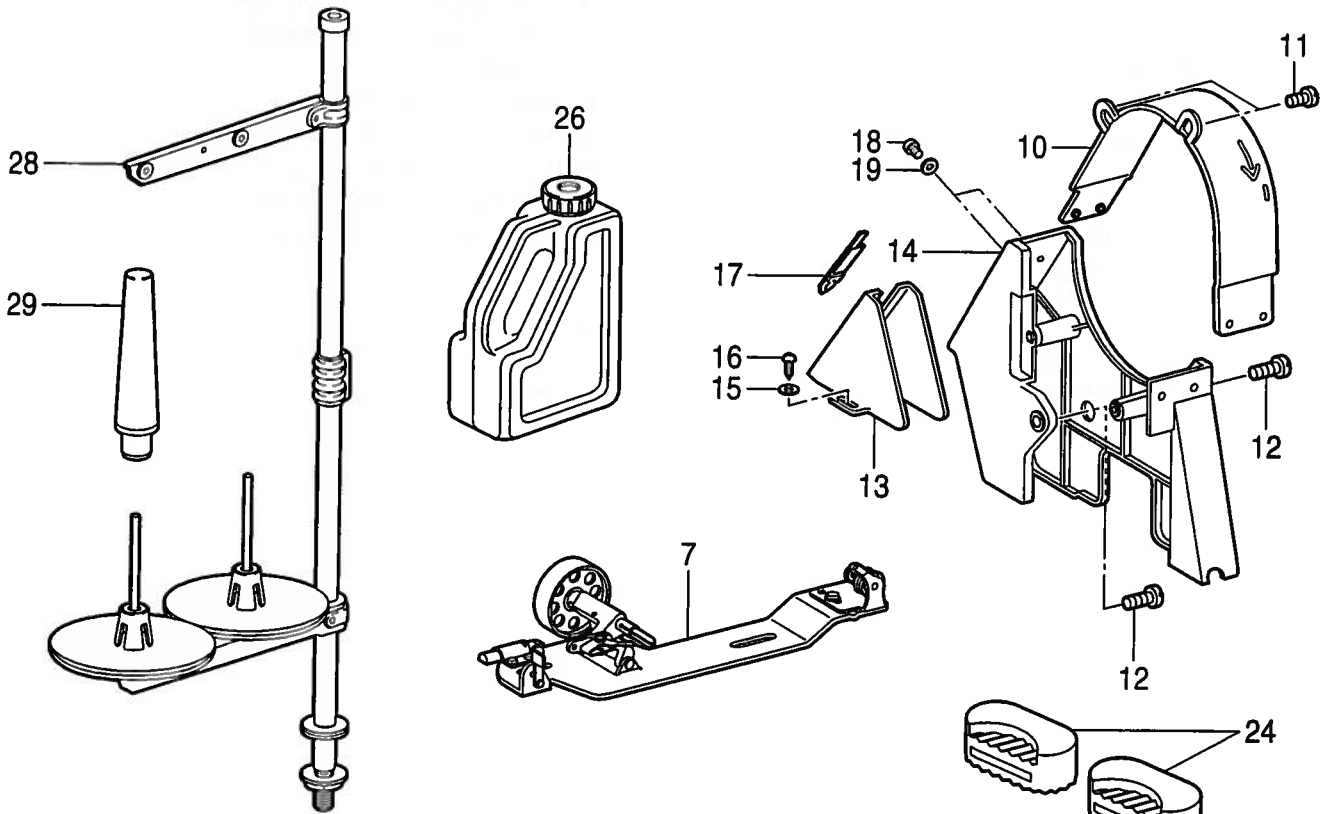

< B728 輸出用 / For Export of B728 >

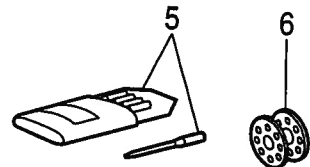
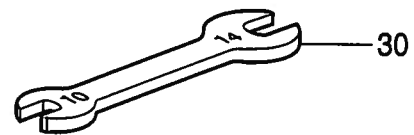
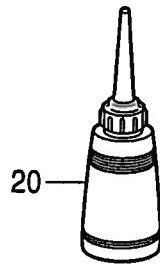
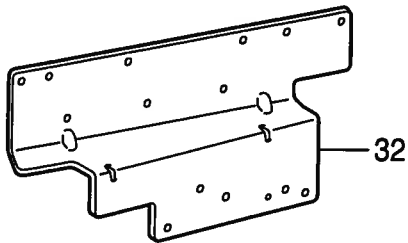

< B728用 / For B728 >

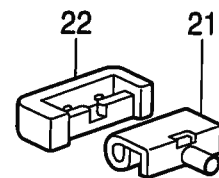
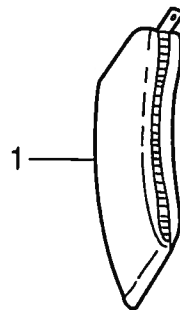
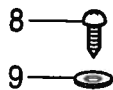
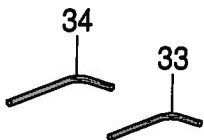

< 輸出用 / For Export only >

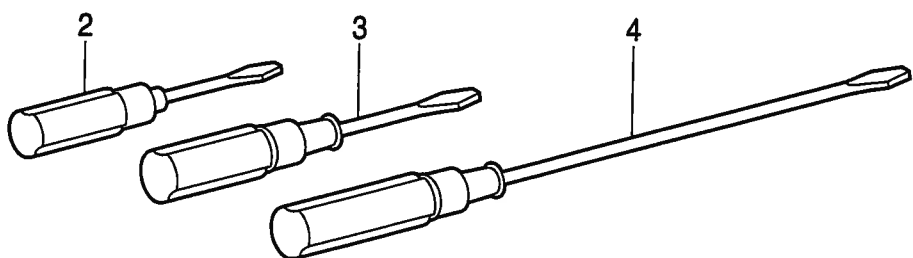
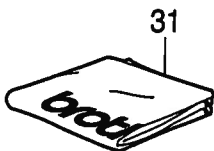



Z. 付属品関係 / Accessories / Zubehör / Accessoires / Accesorios

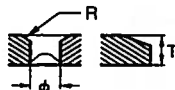
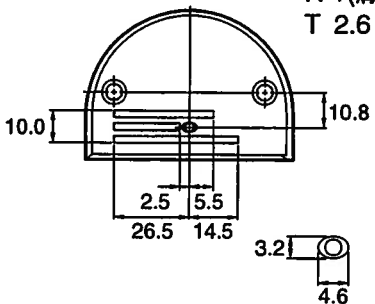
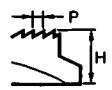
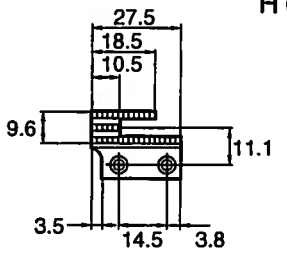

REF.NO.	CODE	Q'TY	ヒンメイ	NAME OF PARTS	RM
1	SW0460001	1	フゾクヒンフクロ	ACCESSORY BAG	
2	142443021	1	ネジマワシ1.9X52	SCREW DRIVER, 1.9X52	
3	118837021	1	ネジマワシ3.4X70	SCREW DRIVER, 3.4X70	
4	S17774021	1	ネジマワシ4.7X250	SCREW DRIVER, 4.7X250	
5	145646423	1	ミシンハリDPX17#23クミ	NEEDLE ASSY, DPX17 (#23)	
6	SW0465001	5	<B727用> ボビン	<For B727> BOBBIN	
6	SW0521001	3	<B728用> ボビン	<For B728> BOBBIN	
7	S14420220	1	イトマキキクミ	BOBBIN WINDER ASSY	
8	SW0467001	2	イトマキキモクネジ	WOOD SCREW, ROUND M5X20	
9	SW0468001	2	イトマキキワツシヤー	WASHER, PLAIN	
10	SW0469001	1	ベルトカバーU	BELT COVER, U	
11	SW0493001	2	シメネジM4X0.7X8	SCREW, M4-0.7X8	
12	SW0494001	2	シメネジM5X0.8X12	SCREW, M5-0.8X12	
13	SW0472001	1	ベルトカバーD	BELT COVER, D	
14	SW0473001	1	ベルトカバー	BELT COVER	
15	SW0474001	2	ベルトカバーDワツシヤー	WASHER, PLAIN	
16	SW0475001	2	ベルトカバーモクネジ	WOOD SCREW, ROUND M5X20	
17	S37264001	1	ベルトカバーDフタS	LID, S ;B-COVER (S)	
18	SW0495001	4	シメネジM4X0.7X5	SCREW, M4-0.7X5	
19	SW0496001	4	ワツシヤー	WASHER, PLAIN	
20	114483001	1	ポリオイラークミ	OILER ASSY	
21	SW0481001	2	トウブヒンジ	HEAD HINGE	
22	SW0482001	2	トウブヒンジウケゴム	RUBBER CUSHION	
24	SW0484001	2	トウブシキゴムF	HEAD CUSHION, F	
25	SW0485001	2	トウブシキゴムB	HEAD CUSHION, B	
26	S35822121	1	オイルタンク	OIL TANK	
28	SW0488001	1	イトタテダイクミ	COTTON STAND ASSY	
29	100477029	1	マクラ	HEAD REST	
30	SW0047001	1	スパナ14X10	WRENCH, 14X10	
31	S35732021	1	<輸出用> トウブカバー	<For Export only> HEAD COVER	
32	J02054001	1	<B728輸出用> HBトリツケイタ#F-1-2	<For Export of B728> SETTING PLATE, HB ;#F-1-2	
33	142002001	1	<B728用> 6カクボウスパナ2	<For B728> HEXAGONAL WRENCH, 2	
34	142721001	1	6カクボウスパナ3	HEXAGONAL WRENCH, 3	

Ga . ゲージ部品一覧表 / Gauge parts List / Lehrenliste / Liste des Pièces decartment /
Lista d'ePiezas de calibradores

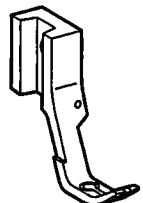
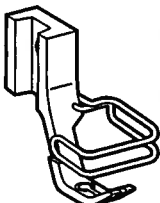

◎標準ゲージ (B727) / Standard Gauge (B727)

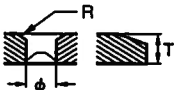
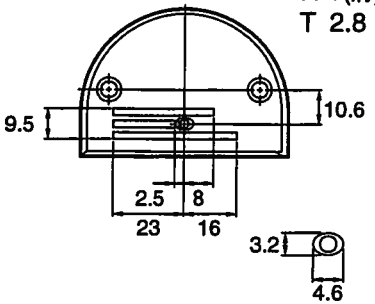
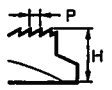
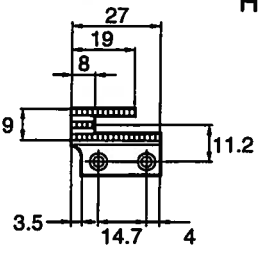
針板 Needle Plate	送り歯 Feed Dog	標準押え Standard Feet		
		送り足 Walking Foot	押え足 Presser Foot	押え足クミ Presser Foot Assy,W/FG
 <p>φ 2.5 R 1(溝) T 2.6</p>  <p>10.0 10.8 2.5 5.5 26.5 14.5 3.2 4.6</p> <p>SW0057-001</p>	 <p>P 1.6 H 6.6</p>  <p>27.5 18.5 10.5 9.6 11.1 3.5 14.5 3.8</p> <p>SW0120-001</p>	 <p>SW0216-001</p>	 <p>SW0083-001</p>	 <p>SW0105-001</p>

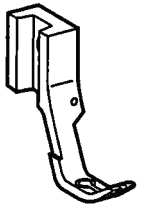
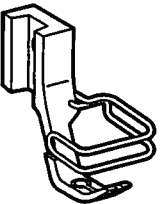

◎標準ゲージ (B728) / Standard Gauge (B728)

針板 Needle Plate	送り歯 Feed Dog	標準押え Standard Feet		
		送り足 Walking Foot	押え足 Presser Foot	押え足クミ Presser Foot Assy,W/FG
 <p>φ 2.6 R 1(溝) T 2.8</p>  <p>9.5 10.6 2.5 8 23 16 3.2 4.6</p> <p>147322-101</p>	 <p>P 1.6 H 6.7</p>  <p>27 19 8 9 11.2 3.5 14.7 4</p> <p>S06629-001</p>	 <p>SW0216-001</p>	 <p>SW0083-001</p>	 <p>SW0105-001</p>

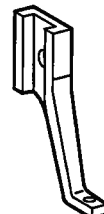
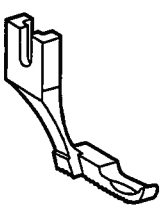
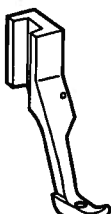
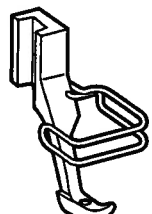
◎オプションゲージ / Option Gauge

パイピング用押え Feet for Piping		小物縫い用押え Narrow type feet for small parts		リバース押え Reverse Feet		
送り足 Walking Foot	押え足 Presser Foot	送り足 Walking Foot	押え足 Presser Foot	送り足 Walking Foot	押え足 Presser Foot	押え足Rクミ Presser Foot Assy,R-W/FG
 <p>151847-001 6.4mm (1/4) 151848-001 7.9mm (5/16) 151849-001 9.5mm (3/8)</p>	 <p>151850-001</p>	 <p>151851-001</p>	 <p>151852-001</p>	 <p>S04501-001</p>	 <p>S04502-101</p>	 <p>S36917-001</p>

Wa. 警告ラベル / Warning labels / Warnschilder / Etiquettes d'avertissement /
Etiquetas de advertencia

警告ラベル / Warning labels	品名 / Name of parts	Size(mm)	Code
	操作注意ラベル・和	40×64	S38350-001
	Label, operation Eng.	40×64	S38349-001
	アースマーク Label, grounding	φ 12	S37060-001

117-727-Wa

索引 / INDEX / VERZEICHNIS /
INDEX / INDICE

CODE	REF.NO.	Page
J02054001	Z -32	28
J80818001	M -5	26
SW0003001	A -3	2
SW0004001	A -4	2
SW0005001	A -5	2
SW0006001	A -6	2
SW0010001	B -1	4
SW0011001	B -2	4
SW0012001	B -3	4
	E -70	12
SW0013001	B -4	4
	D -13	8
	D -30	8
	E -71	12
SW0014001	B -5	4
SW0015001	B -6	4
SW0016001	B -7	4
	B -21	4
	D -28	8
	F -16	16
SW0017001	B -8-1	4
SW0018001	B -9-1	4
SW0019001	B -10-1	4
SW0020001	B -11-1	4
	C -55	6
SW0021001	B -12	4
SW0030001	B -20	4
SW0032001	B -22	4
SW0033001	B -23	4
	F -7	16
	F -9	16
	F -11	16
	F -13	16
SW0034001	B -24	4
SW0035001	B -25	4
SW0036001	B -26	4
SW0040001	B -30	4
SW0041001	B -31	4
	D -27	8
	E -63	12
	E -73	12
	E -77	14
	E -79	14
	E -81	14
	F -32	16
SW0042001	B -32	4
SW0044001	B -34	4
	C -41	6
SW0045001	B -35	4
SW0046001	B -36	4
SW0047001	Z -30	28
SW0048001	B -38	4
SW0049001	B -39-1	4
SW0050001	B -40	4
SW0051001	B -41	4
SW0052001	B -42	4
SW0053001	B -43	4
SW0054001	B -43-1	4
SW0055001	B -43-2	4
SW0056001	B -43-3	4
SW0057001	B -44	4
	Ga -44	29
SW0058001	B -45	4

CODE	REF.NO.	Page
SW0060001	C -1	6
SW0061001	C -2	6
SW0062001	C -3	6
SW0063001	C -4	6
SW0064001	C -5	6
SW0065001	C -6	6
SW0066001	C -7	6
SW0067001	C -8	6
SW0068001	C -9	6
SW0069001	C -11	6
SW0070001	H -18	20
SW0071001	C -16	6
SW0072001	C -17	6
SW0073001	C -18	6
SW0074001	C -19	6
SW0075001	C -20	6
SW0076001	C -30	6
SW0077001	C -31	6
SW0078001	C -32	6
SW0079001	C -33	6
	F -41	16
	F -47	16
	H -11	20
SW0080001	C -34	6
SW0081001	C -35	6
SW0082001	C -36	6
SW0083001	C -37-1	6
	Ga -37-1	29
SW0084001	C -38	6
SW0085001	C -39	6
SW0086001	C -40	6
	C -43	6
	G -19	18
	H -13	20
SW0088001	C -42	6
SW0090001	C -50	6
SW0091001	C -51	6
SW0092001	C -52	6
SW0093001	C -53	6
SW0094001	C -54	6
SW0096001	C -56	6
SW0097001	C -57	6
SW0098001	C -58	6
SW0100001	C -60	6
SW0101001	C -61	6
SW0103001	C -63	6
SW0105001	C -37-3	6
	Ga -37-3	29
SW0120001	D -1	8
	Ga -1	29
SW0121001	D -2	8
SW0122001	D -3	8
SW0123001	D -4	8
SW0124001	D -5	8
SW0125001	D -6	8
SW0126001	D -7	8
	D -20	8
	E -46	12
	D -8	8
SW0127001	D -8	8
SW0128001	D -9	8
SW0129001	D -10	8
	D -31	8
SW0130001	D -11	8

CODE	REF.NO.	Page
SW0130001	D -33	8
SW0131001	D -12	8
	D -29	8
SW0133001	D -14	8
SW0134001	D -15	8
SW0135001	D -16	8
	D -76	10
	E -47	12
SW0136001	D -17	8
	D -42	8
	D -84	10
	E -44	12
SW0137001	D -18	8
SW0138001	D -19	8
SW0140001	D -21	8
SW0141001	D -22	8
	D -23	8
SW0142001	D -24	8
	D -34	8
SW0143001	D -25	8
SW0144001	D -26	8
SW0150001	D -32	8
SW0160001	D -40	8
SW0161001	D -41	8
SW0163001	D -43	8
SW0164001	D -44	8
SW0165001	D -45	8
SW0166001	D -46	8
SW0169001	D -49	8
SW0172001	D -52	8
SW0173001	D -53	8
SW0174001	D -54-1	8
SW0175001	D -55-1	8
SW0176001	D -48	8
	D -56	10
SW0177001	D -57	10
SW0178001	D -58	10
SW0179001	D -59	10
SW0180001	D -60	10
SW0181001	D -61	10
SW0182001	D -62	10
SW0183001	D -63	10
SW0184001	D -64	10
SW0185001	D -65	10
SW0186001	D -66	10
SW0190001	D -70	10
SW0191001	D -71	10
SW0192001	D -72	10
SW0194001	D -74	10
SW0195001	D -75	10
SW0197001	D -77	10
SW0198001	D -78	10
SW0199001	D -79	10
SW0200001	D -80	10
SW0201001	D -81	10
SW0202001	D -82	10
SW0203001	D -83	10
SW0205001	D -85	10
SW0206001	D -86	10
SW0207001	D -87	10
SW0208001	D -88	10
SW0210001	E -1	12
SW0211001	E -2	12

CODE	REF.NO.	Page
SW0212001	E - 3	12
SW0213001	E - 4	12
	E - 31	12
SW0214001	E - 5	12
SW0215001	E - 6	12
SW0216001	E - 7-1	12
	Ga - 7-1	29
SW0217001	E - 8	12
SW0218001	E - 9	12
SW0219001	E - 10	12
	E - 41	12
SW0220001	E - 11	12
SW0221001	E - 12	12
SW0222001	E - 13	12
SW0223001	E - 14	12
SW0224001	E - 15	12
SW0225001	E - 16	12
SW0226001	E - 17	12
SW0227001	E - 18	12
SW0230001	E - 20	12
SW0231001	E - 21	12
SW0232001	E - 22	12
	E - 28	12
SW0233001	E - 23	12
SW0234001	E - 24	12
SW0235001	E - 25	12
SW0236001	E - 26	12
	E - 61	12
SW0237001	E - 27	12
SW0240001	E - 30	12
SW0242001	E - 32	12
SW0243001	E - 33	12
SW0244001	E - 34	12
SW0245001	E - 35	12
SW0250001	E - 40	12
SW0251001	E - 42	12
SW0252001	E - 43	12
SW0254001	E - 45	12
SW0260001	E - 50	12
SW0261001	E - 51	12
SW0262001	E - 52	12
SW0263001	E - 53	12
SW0264001	E - 54	12
SW0265001	E - 55	12
SW0266001	E - 56	12
SW0267001	E - 57	12
SW0268001	E - 58	12
SW0269001	E - 59	12
SW0270001	E - 60	12
	E - 75	14
SW0271001	E - 62	12
SW0282001	E - 72	12
SW0283001	E - 74	14
SW0284001	E - 76	14
SW0290001	D - 89	10
SW0291001	D - 90	10
SW0292001	D - 91	10
SW0293001	D - 92	10
SW0294001	F - 5	16
SW0295001	F - 6	16
SW0297001	F - 8	16
SW0298001	F - 10	16
SW0299001	F - 12	16

CODE	REF.NO.	Page
SW0300001	F - 14	16
SW0301001	F - 15	16
SW0310001	F - 20	16
SW0311001	F - 21	16
SW0312901	F - 22	16
SW0314001	F - 24-1	16
SW0315001	F - 25	16
SW0316001	F - 26	16
SW0317001	F - 27	16
SW0318001	F - 28-1	16
SW0319001	F - 29	16
SW0320001	F - 30	16
SW0321001	F - 31	16
SW0330001	F - 40	16
SW0332001	F - 42	16
SW0333001	F - 43	16
SW0334001	F - 44	16
SW0335001	F - 45	16
	G - 9	18
SW0336001	F - 46-1	16
SW0350001	G - 1	18
SW0351001	G - 2	18
SW0352001	G - 3	18
SW0353001	G - 4	18
SW0354001	G - 5	18
SW0355001	G - 6	18
SW0356001	G - 7	18
SW0357001	G - 8	18
SW0359001	G - 10	18
SW0360001	G - 11	18
SW0361001	G - 12	18
SW0362001	G - 13	18
SW0363001	G - 14	18
SW0364001	G - 15	18
SW0365001	G - 16	18
SW0366001	G - 17	18
SW0367001	G - 18	18
SW0370001	G - 20	18
SW0371001	G - 21	18
SW0372001	G - 22	18
SW0373001	G - 23	18
SW0374001	G - 24	18
SW0380001	G - 30	18
SW0381001	G - 31-1	18
SW0382001	G - 32-1	18
SW0383001	G - 33-1	18
SW0384001	G - 34-1	18
SW0385001	C - 64	6
	G - 35	18
SW0390001	G - 40	18
SW0391001	G - 41	18
SW0392001	G - 42	18
SW0395001	G - 45	18
SW0396001	C - 65	6
SW0397001	G - 47	18
SW0410001	H - 1	20
SW0411001	H - 2	20
SW0412001	H - 3	20
SW0413001	H - 4	20
SW0414001	H - 5	20
SW0415001	H - 6	20
SW0416001	H - 6-1	20
	H - 6-1	20

CODE	REF.NO.	Page
SW0417001	H - 6-2	20
	H - 6-2	20
SW0418001	H - 6-3	20
	H - 6-3	20
SW0419001	H - 6-4	20
SW0420001	H - 6-5	20
	H - 6-5	20
SW0421001	H - 7	20
SW0430001	H - 10	20
SW0431001	H - 10-1	20
SW0432001	H - 10-2	20
SW0433001	H - 10-3	20
SW0434001	H - 10-4	20
SW0435001	H - 10-5	20
SW0436001	H - 10-6	20
SW0437001	H - 10-7	20
SW0438001	H - 10-8	20
SW0439001	H - 17	20
SW0440001	H - 10-10	20
SW0441001	H - 10-11	20
SW0443001	H - 12	20
SW0445001	H - 14	20
SW0446001	H - 15	20
SW0460001	Z - 1	28
SW0465001	Z - 6	28
SW0466001	E - 80	14
SW0467001	Z - 8	28
SW0468001	Z - 9	28
SW0469001	Z - 10	28
SW0472001	Z - 13	28
SW0473001	Z - 14	28
SW0474001	Z - 15	28
SW0475001	Z - 16	28
SW0477001	D - 67	10
SW0481001	Z - 21	28
SW0482001	Z - 22	28
SW0484001	Z - 24	28
SW0485001	Z - 25	28
SW0488001	Z - 28	28
SW0489001	B - 46	4
SW0490001	G - 48	18
SW0491001	G - 49	18
SW0492001	H - 8	20
SW0493001	Z - 11	28
SW0494001	Z - 12	28
SW0495001	Z - 18	28
SW0496001	Z - 19	28
SW0497001	E - 82	14
SW0498001	E - 78	14
SW0503001	B - 35	4
SW0504001	B - 33	4
SW0505000	B - 39-2	4
SW0506001	B - 10-2	4
SW0507001	C - 6	6
SW0508001	D - 55-2	8
SW0509001	D - 73	10
SW0510001	K - 6	24
SW0511001	K - 7	24
SW0512001	K - 14	24
SW0514001	K - 13-1	24
SW0515001	K - 17	24
SW0516000	K - 19	24
SW0517001	K - 20	24

CODE	REF.NO.	Page
SW0518001	F -24-2	16
SW0520001	F -15	16
SW0521001	F -21	16
	Z -6	28
SW0522001	G -31-2	18
SW0523001	G -32-2	18
SW0524001	G -10	18
SW0525001	F -49	16
SW0526001	H -17	20
SW0527001	H -18	20
SW0528001	J -35	22
SW0529001	L -1	24
SW0530001	L -2	24
SW0531001	L -8	24
SW0532001	L -11	24
SW0533001	L -12	24
SW0535001	N -1-1	26
SW0536001	N -1-2	26
SW0543001	G -40	18
SW0544001	G -33-2	18
SW0545001	F -28-2	16
SW0546001	H -6	20
S00337021	J -1	22
S01486001	J -17	22
S01507001	L -13	24
S01510001	L -2-1	24
S02524001	B -8-2	4
S02561021	D -54-2-2	8
S02562001	D -94	10
S02563001	D -93	10
S02578101	D -96	10
S02647001	J -21	22
S02648001	J -60	22
S02652001	J -59	22
S02654001	J -37-1	22
S02655002	J -40	22
S02657101	J -61	22
S02682001	J -53	22
S02684101	M -1	26
S02685001	M -2	26
S02687221	M -7	26
S02701121	N -3	26
S02745001	J -54	22
S02815009	J -34	22
S03327020	M -6	26
S03328000	J -53-1	22
S03670101	L -15	24
S03815001	J -46	22
S04501001	E -7-2	14
	Ga -7-2	29
S04502101	C -37-2	6
	Ga -37-2	29
S06629001	D -1	8
	Ga -1	29
S11210000	J -56	22
S11683000	J -57	22
S11684000	J -56-1	22
S14420220	Z -7	28
S17774021	Z -4	28
S23836001	J -37	22
S25437000	J -18	22
S28926020	M -14	26
S31027020	F -48	16

CODE	REF.NO.	Page
S31885001	C -62	6
S32904000	N -1-3	26
S32905000	N -1-4	26
S32906000	N -1-5	26
S33689002	B -11-2	4
S34756001	C -59	6
S35732021	Z -31	28
S35822121	Z -26	28
S36917001	C -37-4	6
	Ga -37-4	29
S37060001	Wa	30
S37264001	Z -17	28
S38349001	Wa	30
S38350001	Wa	30
S38670001	K -13-3	24
S45840101	D -54-2	8
S45841101	D -54-2-1	8
S54796001	K -5	24
S54799000	G -43	18
013660612	J -48	22
014680622	J -37-2	22
014770622	J -27	22
014771022	J -3	22
048020342	L -14	24
048060342	J -33	22
048180142	J -10	22
060300606	N -1-6	26
060670612	L -7	24
062630712	M -8	26
062670612	M -13	26
	N -4	26
062670812	L -5	24
062671612	L -10	24
062680663	J -55	22
062680712	J -7	22
	N -2	26
062681012	G -34-2	18
	K -18	24
062681612	M -4	26
062711012	M -11	26
062711412	J -19	22
	K -13-2	24
100477029	Z -29	28
100511003	D -97	10
100645003	J -50	22
	M -3	26
101487000	B -9-2	4
102571003	J -16	22
102843004	J -5	22
105234003	J -26	22
110161004	L -3	24
110201001	J -39	22
110367001	J -32	22
113431022	M -10	26
114483001	Z -20	28
118837021	Z -3	28
140647121	M -12	26
142002001	Z -33	28
142274009	J -49	22
142443021	Z -2	28
142721001	Z -34	28
143548000	J -56-2	22
143549000	J -56-3	22

CODE	REF.NO.	Page
143549000	K -5-1	24
145646023	B -37	4
145646423	Z -5	28
146020009	J -41	22
147322101	B -44	4
	Ga -44	29
147337001	F -46-2	16
148537101	J -13	22
149133101	L -9	24
151607001	J -23	22
151845001	F -20	16
151847001	E -7-3	14
	Ga -7-3	29
151848001	E -7-4	14
	Ga -7-4	29
151849001	E -7-5	14
	Ga -7-5	29
151850001	C -37-5	6
	Ga -37-5	29
151851001	E -7-6	14
	Ga -7-6	29
151852001	C -37-6	6
	Ga -37-6	29
151987002	J -15	22
153132000	D -95	10
153969000	J -45	22
154560001	H -6-4	20
154567000	J -2	22
154568101	J -4	22
154576003	J -14	22
154579001	J -20	22
154581001	J -22	22
154582021	J -24	22
154590001	J -25	22
154593201	J -28	22
154594000	J -29	22
154595001	J -30	22
154596000	J -31	22
154599000	J -36	22
154606021	L -4	24
154607121	L -6	24
155559001	J -47	22
156620000	J -9	22
159113001	L -16	24
159793901	F -22	16
159797001	J -6	22
159798001	J -8	22
159799001	J -12	22
204569001	J -53-2	22

brother®

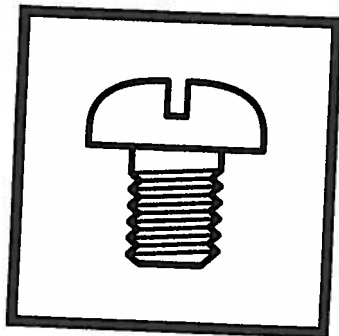

パーツブック
PARTS BOOK
TEILEKATALOG
LIVRE DES PIECES
LIBRO DE REFERENCIA DE PIEZAS

ブラザー工業株式会社

〒467-8561 名古屋市瑞穂区苗代町15番1号 TEL(052)824-2392

BROTHER INDUSTRIES, LTD.

15-1, Naeshiro-cho, Mizuho-ku, Nagoya 467-8561, Japan. Phone: 81-52-824-2177

Printed in Japan / Gedruckt in Japan / Imprimé au Japon / Impreso en Japón

117-727,728
S95727-101
2000.11. F(1)

