



Model

1333

Revision 4 Updated Feb 22, 2012

Technical Manual & Parts Lists

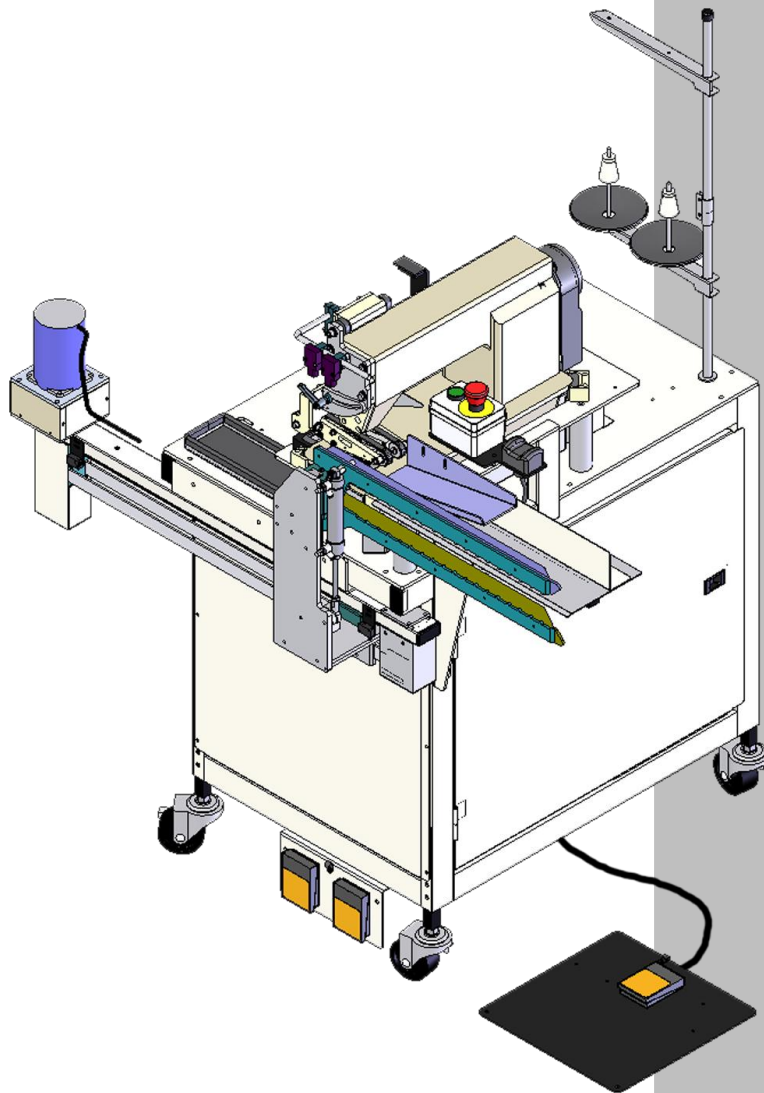

From the library of: Diamond Needle Corp

Atlanta Attachment Company

362 Industrial Park Drive

Lawrenceville, GA 30046

770-963-7369 • www.atlatt.com

ATLANTA ATTACHMENT COMPANY, INC.

Confidential and Proprietary Information

The materials contained herein are confidential and proprietary information of Atlanta Attachment Company. In addition to any confidentiality and non-disclosure obligations that currently exist between you and Atlanta Attachment Company, your use of these materials serves as an acknowledgment of the confidential and proprietary nature of these materials and your duty not to make any unauthorized use or disclosure of these materials.

All materials contained herein are additionally protected by United States Copyright law and may not be used, disclosed, reproduced, distributed, published or sold without the express written consent of Atlanta Attachment Company, which consent may be withheld in Atlanta Attachment Company's sole discretion. You may not alter or remove any copyright, trademark or other notice from copies of these materials.

Patents & Patents Pending

The sale of this product does not sell or otherwise transfer any license or other rights under any U.S. Patent or other corresponding foreign patent.

This equipment is manufactured under one or more of the following patents:

4,280,421 • 4,432,294 • 4,466,367 • 4,644,883 • 5,134,947 • 5,159,889 • 5,203,270 • 5,373,798 • 5,437,238 • 5,522,332 • 5,524,563 • 5,562,060 • 5,634,418 • 5,647,293 • 5,657,711 • 5,743,202 • 5,865,135 • 5,899,159 • 5,915,319 • 5,918,560 • 5,924,376 • 5,979,345 • 6,035,794 • 6,055,921 • 6,202,579 • 6,279,869 • 6,295,481 • 6,494,225 • 6,523,488 • 6,574,815 • 6,802,271 • 6,834,603 • 6,968,794 • 6,994,043 • 7,543,364 • 7,574,788 • 7,647,876 • 7,735,439

Foreign Patents: 9-520,472 • 0,537,323 • 92,905,522.6 • 96,936,922.2 • 2,076,379 • 2,084,055
Other U.S. and Foreign Patents Pending.

IMPORTANT

It is important to read and understand the information contained within this manual before attempting to operate the machine. Atlanta Attachment Co., Inc. shall not be held liable for damage resulting from misuse of the information presented within, and reserves the right to change the information contained within, without prior notification.

Contents

Important Safety Instruction	1
Liability	2
Safety Equipment on the Machines	3
Protective Eyewear	4
Important Notices.....	5
Maintenance	7
Repair	8
A Word to the End User.....	9
Safety Precautions.....	9
Features	10
General Machine Data	10
Installation.....	11
Machine Start-Up.....	11
Semi-Automatic Operation	12
Manual Operation	12
Machine Error Codes	13
1333-PAR Parameter Settings	14
Electric Eye Sensor Adjustment	15
Reflective Tape Maintenance	15
Notes	16
Assembly Drawings & Parts Lists	17
11333 Semi-Automatic Border Closing Workstation.....	19
1333010 Closer Station Assembly.....	21
1333100 Transfer Assembly.....	23
1333200 Gripper Assembly	25
1333400 Control Panel Assembly	27
32006600A Sewing Head Assembly	29
32007850 Pivot Assembly	31
1333-PD Pneumatic Diagram	32
1333-WD Wiring Diagram	33

Important Safety Instruction



This part of the Instruction Material is provided for the safe use of your equipment. It contains important information to help work safely with the unit and describes the dangers inherent in machinery. Some of these dangers are obvious, while others are less evident.

Mandatory Information

All persons operating and/or working on the 1333Semi-Auto Border Closing Workstation should read and understand all parts of the Safety Instructions. This applies, in particular, for persons who only operate and/or work on the unit occasionally (e.g. for maintenance and repair). Persons who have difficulty reading must receive particularly thorough instruction.

Scope of the Instruction Material

- The Instruction Material comprises:
- Safety information
- Operator Instructions
- Electrical and Pneumatic diagrams

And may also include;

- A list of recommended spare parts
- Instruction Manual(s) for components made by other manufacturers
- The layout and installation diagram containing information for installation

Intended Use

Our machines are designed and built in line with the state of the art and the accepted safety rules. However, all machines may endanger the life and limb of their users and/or third parties and be damaged or cause damage to other property, particularly if they are operated incorrectly or used for purposes other than those specified in the Instruction Manual.

Exclusion of Misuse



Non-conforming uses include, for example, using the equipment for something other than it was designed for, as well as operation without duly installed safety equipment. The risk rests exclusively with the end user.

Conforming use of the machine includes compliance with the technical data, information and regulations in all parts of the complete Instruction Material, as well as compliance with the maintenance regulations. All local safety and accident prevention regulations must also be observed.

Liability

The machine should only be operated when in perfect working order, with due regard for safety and the potential dangers, as well as in accordance with the Instruction Material. Faults and malfunctions capable of impairing safety should be remedied immediately. We cannot accept any liability for personal injury or property damage due to operator errors or non-compliance with the safety instructions contained in this booklet. The risk rests exclusively with the end user.

The Instruction Material should always be kept near the machine so that it is accessible to all concerned.

The local, general, statutory and other binding regulations on accident prevention and environmental protection must also be observed in addition to the Instruction Material. The operating staff must be instructed accordingly. This obligation also includes the handling of dangerous substances and provision/use of personal protective equipment.

The Instruction Material should be supplemented by instructions, including supervisory and notification duties with due regard for special operational features, such as the organization of work, work sequences, the personnel deployed, etc.

The personnel's awareness of the dangers and compliance with the safety regulations should be checked at irregular intervals.

Choice and Qualification of Personnel

Ensure that work on the machine is only carried out by reliable persons who have been appropriately trained for such work - either within the company, by our field staff or at our office - and who have not only been duly appointed and authorized, but are also fully familiar with the local regulations. Work on the machine should only be carried out by skilled personnel, under the management and supervision of a duly qualified engineer.

This not only applies when the machine is used for production, but also for special work associated with its operation (start-up and maintenance), especially when it concerns work on the hydraulic or electrical systems, as well as on the software/serial bus system.

Training

Everyone working on or with the machine should be duly trained and informed with regard to correct use of the safety equipment, the foreseeable dangers which may arise during operation of the machine and the safety precautions to be taken. In addition, the personnel should be instructed to check all safety mechanisms at regular intervals.

Responsibilities

Clearly define exactly who is responsible for operating, setting-up, servicing and repairing the machine. Define the responsibilities of the machine operator and authorize him to refuse any instructions by third parties if they run contrary to the machine's safety. This applies in particular for the operators of machines linked to other equipment. Persons receiving training of any kind may only work on or with the machine under the constant supervision of an experienced operator. Note the minimum age limits permitted by law.

A Word to the Operator

The greatest danger inherent in our machines: is that of fingers, hands or loose clothing being drawn into a machine by live, coasting or rotating tools or assemblies or of being cut by sharp tools or burned by hot elements.

ALWAYS BE CONSCIOUS OF THESE DANGERS!

Safety Equipment on the Machines



All machines are delivered with safety equipment, which shall not be removed or bypassed during operation.

The correct functioning of safety equipment on machines and systems should be checked every day and before every new shift starts, after maintenance and repair work, when starting up for the first time and when restarting (e.g. after prolonged shutdowns).

If safety equipment has to be dismantled for setting-up, maintenance or repair work, such safety equipment shall be replaced and checked immediately upon completing the maintenance or repair work. All protective mechanisms shall be fitted and fully operational whenever the machine is at a standstill or if it has been shut down for a longer period of time.

Damage

If any changes capable of impairing safety are observed in the machine or its mode of operation, such as malfunctions, faults or changes in the machine or tools, appropriate steps must be taken immediately, the machine switched off and a proper lockout tagout procedure followed. The machine should be examined for obvious damage and defects at least once per shift. Damage found shall be immediately remedied by a duly authorized person before resuming operation of machine.

The machine should only be operated when in perfect working order and when all protective mechanisms and safety equipment, such as detachable protective mechanisms, emergency STOP systems, etc. are in place and operational.

Faults or Errors

The machine must be switched off and all moving or rotating parts allowed to come to a standstill and secured against accidental restart before starting to remedy any faults or errors.

Signs on the Machine

Safety and danger signs on the machine should be observed and checked at regular intervals to ensure that they are complete and undamaged. They should be clearly visible and legible at all times.

Clothing, Jewelry, Protective Equipment

Long loose hair, loose-fitting clothes, gloves and jewelry, including rings, should be avoided in order to avoid injuries due to being caught, drawn in and wound up inside the machine.

Protective Eyewear

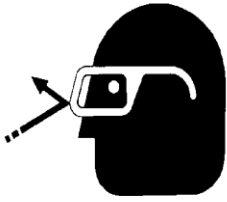

Protective eyewear that has been tested by the local authorities should be worn whenever there is a possibility of loose or flying objects or particles such as when cleaning the machine with compressed air.

Tools

Always count the number of tools in your possession before starting work on the machine. This will allow you to check that no tools have been left behind inside the machine. Never leave a tool in the machine while working.

Oils, Lubricants, Chemicals

Note the applicable safety regulations for the product used.

No Smoking, Fire, Explosion Hazard

Smoking and open flame (e.g. welding work) should be prohibited in the production area due to the risk of fire and explosions.

Workplace

A clear working area without any obstructions whatsoever is essential for safe operation of the machine. The floor should be level and clean, without any waste.

The workplace should be well lit, either by the general lighting or by local lights.

Emergency STOP

The emergency STOP buttons bring all machine movements to a standstill. Make sure you know exactly where they are located and how they work. Try them out. Always ensure easy access to the nearest emergency STOP button while working on the machine.

First Aid

1. Keep calm even when injured.
2. Clear the operator from the danger zone. The decision of what to do and whether to seek additional assistance rests entirely with you, particularly if someone has been trapped.
3. Give First Aid. Special courses are offered by such organizations as the employers' liability insurance association. Your colleagues should be able to rely on you and vice versa.
4. Call an ambulance. Do you know the telephone numbers for the ambulance service, police and fire service?

Important Notices

Reporting and Fighting Fires

Read the instructions posted in the factory with regard to reporting fires and the emergency exits. Make sure you know exactly where the fire extinguishers and sprinkler systems are located and how they are operated. Pass on the corresponding information to the firemen when they arrive. Ensure there are enough signs to avoid fire hazards.

The following fire extinguishers may be used:

- Dry powder extinguishers, ABC fire-extinguishing powder.
- Carbon dioxide fire extinguishers to DIN 14461 for electronic components. Great care must be exercised when using carbon dioxide fire extinguishers in confined, badly ventilated rooms (see DIN 14406 and 14270).

Isolate the machine from the power supply if a fire breaks out. Do not use water on burning electrical parts until it is absolutely certain that they have been completely disconnected from the power supply. Burning oils, lubricants, plastics and coatings on the machine can give off gases and vapors that may be harmful to your health.

A qualified person should be consulted to repair the damage after a fire.

Electrical Power Supply

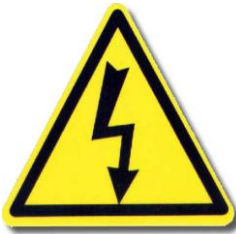

Before undertaking any maintenance or repair work on the machine, switch off the electrical power to the machine at the main source and secure it with a padlock so that it cannot be switched on again without authorization.

In practice, this may mean that the technician, electrician and operator all attach their own padlock to the master switch simultaneously so that they can carry out their work safely. Locking extension plates should be available for multiple locks if required. The primary purpose for a lockout/tagout procedure is to protect workers from injury caused by unexpected energizing or start-up of equipment.

Energy sources (electrical/pneumatic/hydraulic, etc.) for the equipment shall be turned off or disconnected and the switches locked or labeled with a warning tag. It is the responsibility of the employer to establish control procedures. Follow lockout/tagout procedures before, setup and/or any service or maintenance work is performed, including lubrication, cleaning or clearance of jams.

Caution: The machine is still not completely de-energized even when the master switch is off.

- Electricity - The machine is always isolated from the electrical power supply whenever the master switch has been switched off. However, this does not apply for the power supply in the control cabinet, nor for equipment that does not draw its power via the master switch.
- Pneumatic / hydraulic energy - Almost all our machines carry compressed air. In addition to switching off the master switch, the air supply must also be disconnected and the machine checked to ensure it is depressurized before starting any work on the machine; otherwise the machine may execute uncontrolled movements.

- Kinetic energy - Note that some motors or spindles, for example, may continue to run or coast run on after being switched off.
- Potential energy - Individual assemblies may need to be secured if necessary for repair work.

Delivery of the Machine/Packaging

Note any markings on the packaging, such as weights, lifting points and special information. Avoid temperature fluctuations. Condensation may damage the machine.

Transport Damage

The packaging and machine must immediately be examined for signs of damage in transit. Such damage must be reported to the shipper/transporter within the applicable time limits. Contact Atlanta Attachment Company and/or your transport insurer immediately, if signs of damage are visible. Never operate a damaged machine.

Interim Storage

If the machine has to be stored temporarily, it must be oiled or greased and stored in a dry place where it is protected from the weather in order to avoid damage. A corrosion-inhibiting coating should be applied if the machine has to be stored for a longer period of time and additional precautions taken to avoid corrosion.

Transporting the Machine

Disconnect the machine from all external connections and secure any loose assemblies or parts. Never step under a suspended load. When transporting the machine or assemblies in a crate, ensure that the ropes or arms of a forklift truck are positioned as close to the edge of the crate as possible. The center of gravity is not necessarily in the middle of the crate. Note the accident prevention regulations, safety instructions and local regulations governing transport of the machine and its assemblies.

Only use suitable transport vehicles, hoisting gear and load suspension devices that are in perfect working order and of adequate carrying capacity. Transport should only be entrusted to duly qualified personnel.

Never allow the straps to rest against the machine enclosure and never push or pull sensitive parts of the machine. Ensure that the load is always properly secured. Before or immediately after loading the machine, secure it properly and affix corresponding warnings.

All transport guards and lifting devices must be removed before the machine is started up again. Any parts that are to be removed for transport must be carefully refitted and secured before the machine is started up again.

Workplace Environment

Our machines are designed for use in enclosed rooms: Permissible ambient temperature approx. 5 - 40 °C (40 - 104 °F). Malfunctions of the control systems and uncontrolled machine movements may occur at temperatures outside this range.

Protect against climatic influences, such as electrostatic charges, lightning strikes, hail, storm damage, high humidity, salinity of the air in coastal regions.

Protect against influences from the surroundings: no structure-borne vibrations, no grinding dust, or chemical vapors.

Protect against unauthorized access.

Ensure that the machine and accessories are set up in a stable position.

Ensure easy access for operation and maintenance (Instruction Manual and layout diagram); also verify that the floor is strong enough to carry the weight of the machine.

Local Regulations

Particular attention must be paid to local and statutory regulations, etc. when installing machines and the plant (e.g. with regard to the specified escape routes). Note the safety zones in relation to adjacent machines.

Maintenance

General Safety Instructions

The machine shall be switched off, come to a standstill and be secured so that it cannot be switched on again inadvertently before starting any maintenance work whatsoever. Use proper lockout/tagout procedures to secure the machine against inadvertent startup.

Remove any oil, grease, dirt and waste from the machine, particularly from the connections and screws, when starting the maintenance and/or repair work. Do not use any corrosive-cleaning agents. Use lint-free rags.

Retighten all screw connections that have to be loosened for the maintenance and repair work. Any safety mechanisms that have to be dismantled for setting-up, maintenance or repair purposes must be refitted and checked immediately after completing the work.

Maintenance, Care, Adjustment

The activities and intervals specified in the Instruction Manual for carrying out adjustments, maintenance and inspections must be observed and parts replaced as specified.

All hydraulic and pneumatic lines should be examined for leaks, loose connections, rubbing and damage whenever the machine is serviced. Any defects found must be remedied immediately.

Waste, Disassembly, Disposal

Waste products should be cleared from the machine as soon as possible as not to create a fire hazard. Ensure that fuels and operating lubricants, as well as replacement parts are disposed of in a safe and ecologically acceptable manner. Note the local regulations on pollution control.

When scrapping (disassembling) the machine and its assemblies, ensure that these materials are disposed of safely. Either commission a specialist company familiar with the local regulations or note the local regulations when disposing of these materials yourself. Materials should be sorted properly.

Repair

Replacement Parts

We cannot accept any liability whatsoever for damage due to the use of parts made by other manufacturers or due to unqualified repair or modification of the machine.

Repair, Electrical

The power supply must be switched off (master switch off) and secured so that it cannot be switched on again inadvertently before starting any work on live parts.

Those parts of the machine and plant on which inspection, maintenance or repair work is to be carried out must be isolated from the power supply, if specified. The isolated parts must first be checked to determine that they are truly de-energized before being grounded and short-circuited. Adjacent live parts must also be isolated.

The protective measures implemented (e.g. grounding resistance) must be tested before restarting the machine after all assembly or repair work on electric parts.

Signal generators (limit switches) and other electrical parts on the safety mechanisms must not be removed or bypassed. Only use original fuses or circuit overloads with the specified current rating. The machine must be switched off immediately if a fault develops in the electrical power supply.

The electrical equipment of our machines must be checked at regular intervals and any defects found must be remedied immediately.

If it is necessary to carry out work on live parts, a second person should be on hand to operate the emergency OFF switch or master switch with voltage release in the event of an emergency. The working area should be cordoned off and marked by a warning sign. Only use electrically insulated tools.

Ventilation/Hazardous Gases

It is the end users responsibility to ensure adequate ventilation is provided to exhaust any and all noxious or hazardous gases that may be present in the working environment.

Hydraulic and Pneumatic Systems

Work on hydraulic or pneumatic equipment shall only be carried out by persons with training, knowledge and experience of hydraulic systems. Pressure lines shall be depressurized before starting any repair work.

General Liability

Liability for machine damage and personal injury is extinguished completely if any unauthorized conversions or modifications are undertaken. The machine must not be modified, enlarged or converted in any way capable of affecting safety without the manufacturer's prior approval.

Starting Machine Movements

Read the Instruction Manual carefully to establish which keys and functions start machine movements.

A Word to the End User

The end user has sole responsibility to enforce the use of safety procedures and guards on the machine. Any other safety devices or procedures due to local regulations should be should be retrofitted in accordance to these regulations and/or the EC Directive on the safety of machines.

Operator's position must always be readily accessible. Escape routes must always be kept clear and safety areas should be identified.

Safety Precautions

Safety should be a constant concern for everyone. Always be careful when working with this equipment. While normal safety precautions were taken in the design and manufacture of this equipment, there are some potential safety hazards.

Everyone involved with the operation and maintenance of this equipment should read and follow the instructions in this manual.

Operate the equipment only as stated in this manual. Incorrect use could cause damage to the equipment or personal injury.

It is the owner's responsibility to make certain that the operator reads and understands this manual before operating this equipment. It is also the owner's responsibility to make certain that the operator is a qualified and physically able individual, properly trained in the operation of this equipment.

Specific safety warning decals are located on the equipment near the immediate areas of potential hazards. These decals should not be removed or obliterated. Replace them if they become non-readable.

- ALWAYS keep safety shields and covers in place, except for servicing.
- ALWAYS operate equipment in daylight or with adequate working lights.
- Follow daily and weekly checklists, making sure hoses are tightly secured and bolts are tightened.
- ALWAYS watch and avoid holes or deep depressions.
- ALWAYS wear adequate eye protection when servicing the hydraulic system and battery.
- NEVER operate a poorly maintained machine.
- NEVER allow persons to operate this machine without proper instruction.
- NEVER put hands or feet under any part of the machine while it is running.
- NEVER attempt to make any adjustments or repairs to the machine while running. Repairs or maintenance should be performed by trained personnel only.
- NEVER work under the machine unless it is safely supported with stands, blocks or a hoist and blocks.
- NEVER touch hot parts of machine.

The 1333 unit is a stand-alone, semi-automatic border closing workstation which can be moved to any department as needed.

Features

- Heavy-duty lockstitch sewing head
- Lockstitch ensures no stitch ravel at tape edge operation
- Tractor style top feed swings up for easy threading and maintenance
- Closes all borders up to 18" wide without adjustment
- Auto needle positioning, footlift and thread trimmer

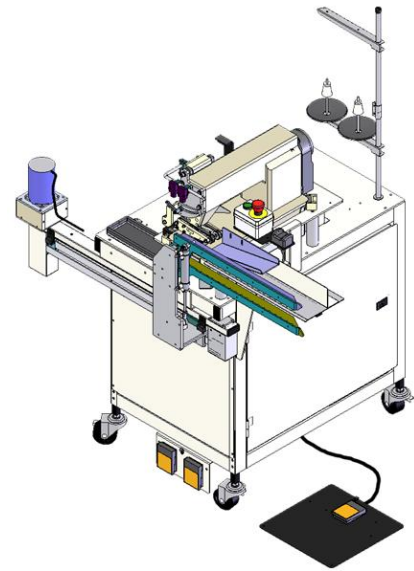

General Machine Data

Electrical:	220VAC, 10A, 50/60 Hz Single Phase Power
Pneumatic:	40 PSI, 1 SCFM
Sew Heads:	Mitsubishi LS2-1380
Needle:	DLX1/Size 140 (16 x 95) AAC Part # SNDLX1140
Speed:	1800 RPM
Weight:	Approx. 500 Lbs.
Dimensions:	4'5" W, 3'3" L, 5'4" H

Installation

1. Connect the machine's power cord to 220VAC, 50-60 Hz Single Phase.
2. Connect compressed air supply to the Air Pressure Regulator.(See Figure 1 for component location)
3. Place the Gripper Pedal in position and connect it's cable if required.(See Figure 2 for component location)
4. Switch power by pressing the green button on the Main Power Disconnect.(See Figure 1 for component location)
5. Adjust the Air Pressure Regulator to 40 PSI by pulling up the adjustment knob on the top of the regulator and turning clockwise to increase pressure or counter-clockwise to decrease pressure. After adjustment has been made, push the adjustment knob back down to its locked position.(See Figure 1 for component location)

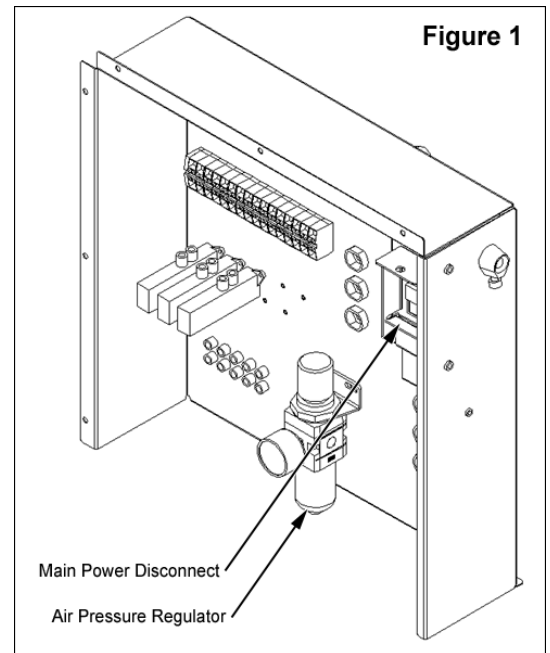

Machine Start-Up

Make sure that both Electric Photo Eyes are not blocked. Powering up with one or both eyes blocked changes the mode of operation to Manual Mode (See “Manual Operation” on page 3).

Make sure the E-Stop button is reset (turn the E-Stop button clockwise until it clicks and springs up) and press the green Start button. The Gripper Carriage will jog to the Home position if not there already.

Allow approximately 5 seconds for the program to initialize before operation.

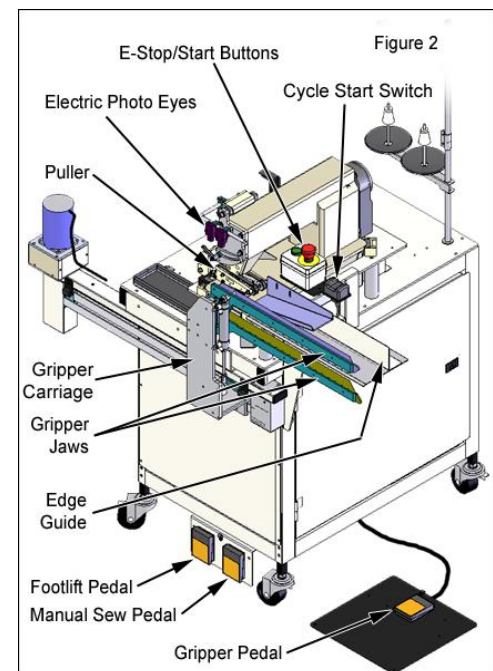

Semi-Automatic Operation

Note: If either the Manual Sew or Footlift Pedals are pressed, at any time, the machine will switch to Manual Mode.

1. Bring the two ends of the border together and insert them between the Gripper jaws and against the Edge Guide.
(See Figure 2 on page 2 for component location)
2. Slide the border as far left as possible.

Warning: Do not put hands between the upper and lower Gripper jaws.

3. Press and hold the Gripper Pedal to close the jaws. Releasing the pedal at any time before touching the Cycle Start Switch will open the jaws.
(See Figure 2 on page 2 for component location)
4. With the Gripper Pedal depressed, touch the Cycle Start Switch.
(See Figure 2 on page 2 for component location)
5. The border is sewn automatically and the Gripper jaws open at the end of the sewing cycle. Remove the border. The Gripper will jog back to the Home position.

When the Gripper is back in the Home position, the machine is ready for another cycle to begin.



Manual Operation

Powering up with either or both Electric Photo Eyes blocked will initialize Manual Mode. Also pressing either the Manual Sew or Footlift pedals will switch the machine to Manual Mode.

In Manual Mode, the Puller is raised and the Gripper jaws are open. Touching the Cycle Start Switch will move the Gripper out of the way.

To return to Semi-Automatic Mode, unblock both Electric Photo Eyes and reset power by pushing the E-Stop button and resetting it then push the Green Start button. Refer to “Machine Start-Up” on page 2.

Machine Error Codes

Listed below are the possible error codes which will be displayed, in case of an error, on the Efka motor control box located under the table top.
 (See Figure 4 for component location and identification)

To clear, reset power. Refer to “Machine Start-Up” on page 2.

ERROR CODE DISPLAYED	DEFINITION
U1	Gripper Pedal stuck down upon power up.
U2	Manual Sew Pedal stuck down upon power up.
U3	Footlift Pedal stuck down upon power up.
U4	Cycle Start Switch touched upon power up.
U5	Puller Eye covered upon power up (Manual Mode). See Figure 4.
U6	Foot Eye covered upon power up (Manual Mode). See Figure 4.
U7	Puller Eye covered when Cycle Start Switch is activated. See Figure 4.
U8	Foot Eye covered when Cycle Start Switch is activated. See Figure 4.
U9	Carriage crash. Leading edge did not cover Foot Eye. See Figure 4.
U10	Carriage crash. Trailing edge did not uncover Puller Eye. See Figure 4.
U11	Gripper Pedal activated during Manual Mode.

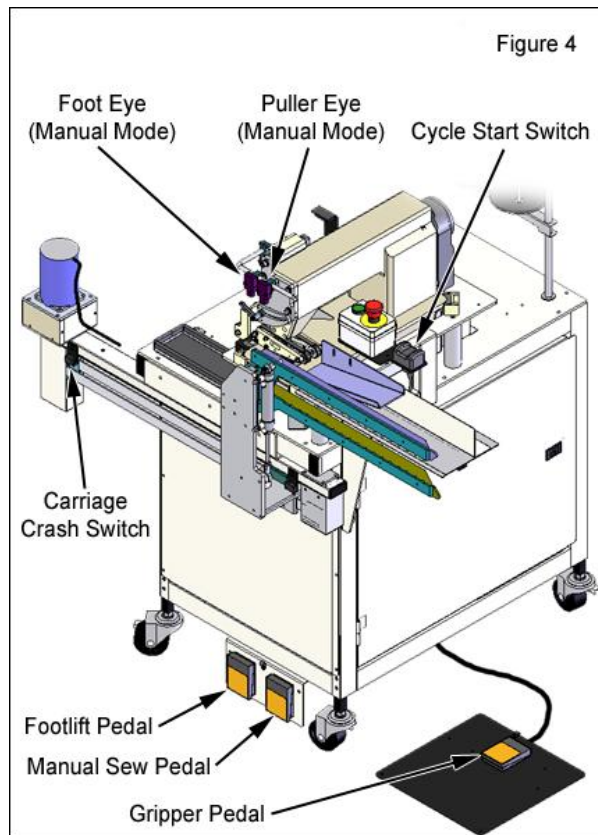

1333-PAR Parameter Settings

Parameter	Range	Value	Description
290	0-24	14	Mode of Operation. MUST BE SET FIRST!
100	0-254	2	Number of soft start stitches.
111	200-9900 rpm	180	Maximum Speed when “129” is 0, 1 or 2.
134	0-1	1	Soft start enable.
161	0-1	1=CCW	Motor Rotation
180	0-360	60	Degrees reverse run goes to get to needle up
181	0-999	50	Delay till reverse run starts after trim
182	0-1	1	Enable reverse run after trim to get to “true” needle up
202	0-500	250	Start sew delay after footlift turns off.
204	1-100%	100	F/L solenoid holding power
219	20090	35	Positioning power at stop
240	0-31	16	Backtack input for In1 (reverse sewing)
250	0-259	150	Activation angle of thread trimmer
254	1-100%	100	Upper limit for 204
270	0-5	1	External handwheel sensor configuration.
272	020-255	100	Drive ratio between motor pulley and handwheel pulley. If handwheel pulley is smaller than motor pulley, increase this value to slow down sewing head until measured speed matches speed set with parameter 111.

From the library of: Diamond Needle Corp

Front Panel LED's:

- LED 1: Off
- LED 2: Off
- LED 3: Off
- LED 4: Off
- LED 5: Off
- LED 6: Off
- LED 7: Off, Stop at needle down.
- LED 8: On, Stop at needle up.

Programming Instructions

1. Power on holding down the “P” button until “COD” is displayed.
2. Press “>>” once and enter the number 311.
3. Press “E” once and “2.0.0” is displayed.
4. Proceed to the parameter to be changed and press “E”.
5. The value now shows in the screen. Adjust to desired value.
6. Press “E” to enter value and continue with parameter setting.
7. Repeat for other parameters. Press “P” once when complete.
8. Run sewing head to save parameters before powering down.

Electric Eye Sensor Adjustment

To adjust the sensor, first remove the clear plastic cover from the end of the sensor. There are two adjusting screws under the cover. One is labeled “GAIN” and is used to set the sensitivity of the sensor. The other screw is labeled “DO & LO” and should always be fully clockwise.

With the end of the sensor pointing at the center of the reflective tape, turn the “GAIN” screw counter-clockwise until the red LED indicator is off. Then turn the “GAIN” screw clockwise until the LED indicator comes on. Then turn the “GAIN” screw one full turn clockwise. The LED indicator should be blinking slowly. Cover the eye so that the sensor cannot see the reflective tape and the LED should go off.

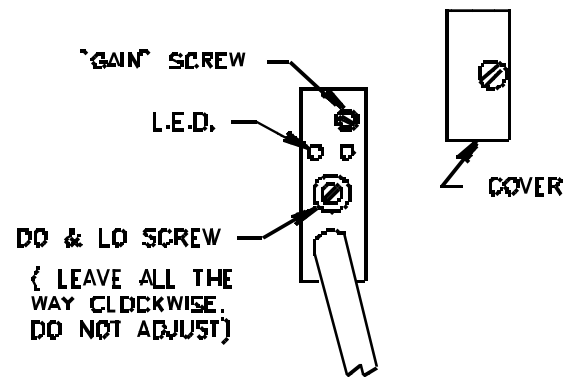

Reflective Tape Maintenance

- Use a soft cloth for cleaning.
- Do not use chemicals or abrasives to clean it.
- Avoid any contact with oils and liquids.
- Do not touch the tape with bare fingers.
- If tape is dirty or opaque, the eye may not function correctly.

Notes

From the library of: Diamond Needle Corp

Assembly Drawings & Parts Lists

The materials contained herein are confidential and proprietary information of Atlanta Attachment Company. In addition to any confidentiality and non-disclosure obligations that currently exist between you and Atlanta Attachment Company, your use of these materials serves as an acknowledgment of the confidential and proprietary nature of these materials and your duty not to make any unauthorized use or disclosure of these materials.



One-Stop Shopping
For Expendable Replacement Parts for AAC & Other Bedding Equipment Suppliers
Toll Free: **1-866-885-5100**
www.atlantapartsdepot.com • sales@atlantapartsdepot.com

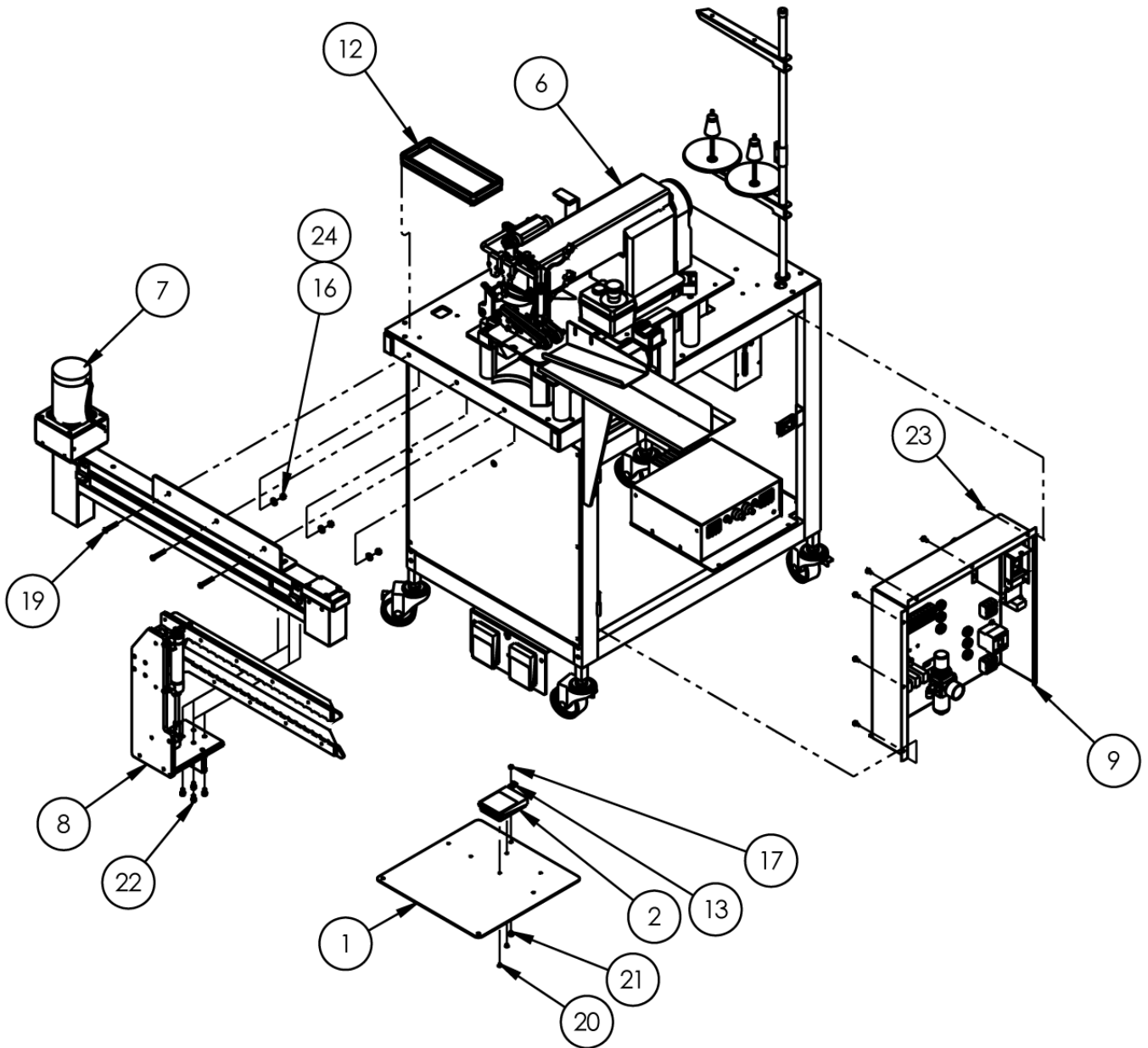

11333 Semi-Automatic Border Closing Workstation

AAC Drawing Number 9000851 Rev2

NO.	QTY	PART #	DESCRIPTION	
1	1	1278-5281	Foot Pedal Plate	
2	1	1278-6161	Foot Switch	
3	AR	1333CAB	Cable Package	
4	1	1333-PAR	Parameter List	Page 14
5	1	1333-PD	Pneumatic Diagram	Page 32
6	1	1333-WD	Wiring Diagram	Page 33
7	1	1333010	Closer Station Assembly	Page 21
8	1	1333100	Transfer Assembly	Page 23
9	1	1333200	Gripper Assembly	Page 25
10	1	1333400	Control Panel Assembly	Page 27
11	1	1333LAB	Labels	
12	1	26151	Tool Tray	
13	1	AAF3/16	Plastic Clamp	
14	2	AAVBG35B	Coiled Hose	
15	1	EEFE-RR2	Reflective Tape	
16	3	NNK1/4-20	Kep Nut	
17	1	NNK8-32	Kep Nut	
18	1	SNDLX1140	Needle	
19	3	SSBC01096	Screw, Button Cap	
20	2	SSFC80016	Screw, Flat Allen	
21	1	SSFC90024	Screw, Flat Allen	
22	6	SSZS93032	Screw, Sheet Metal	
23	3	WWFS1/4	Flat Washer	
24	4	SSSCM6X10	Screw, Socket Cap	

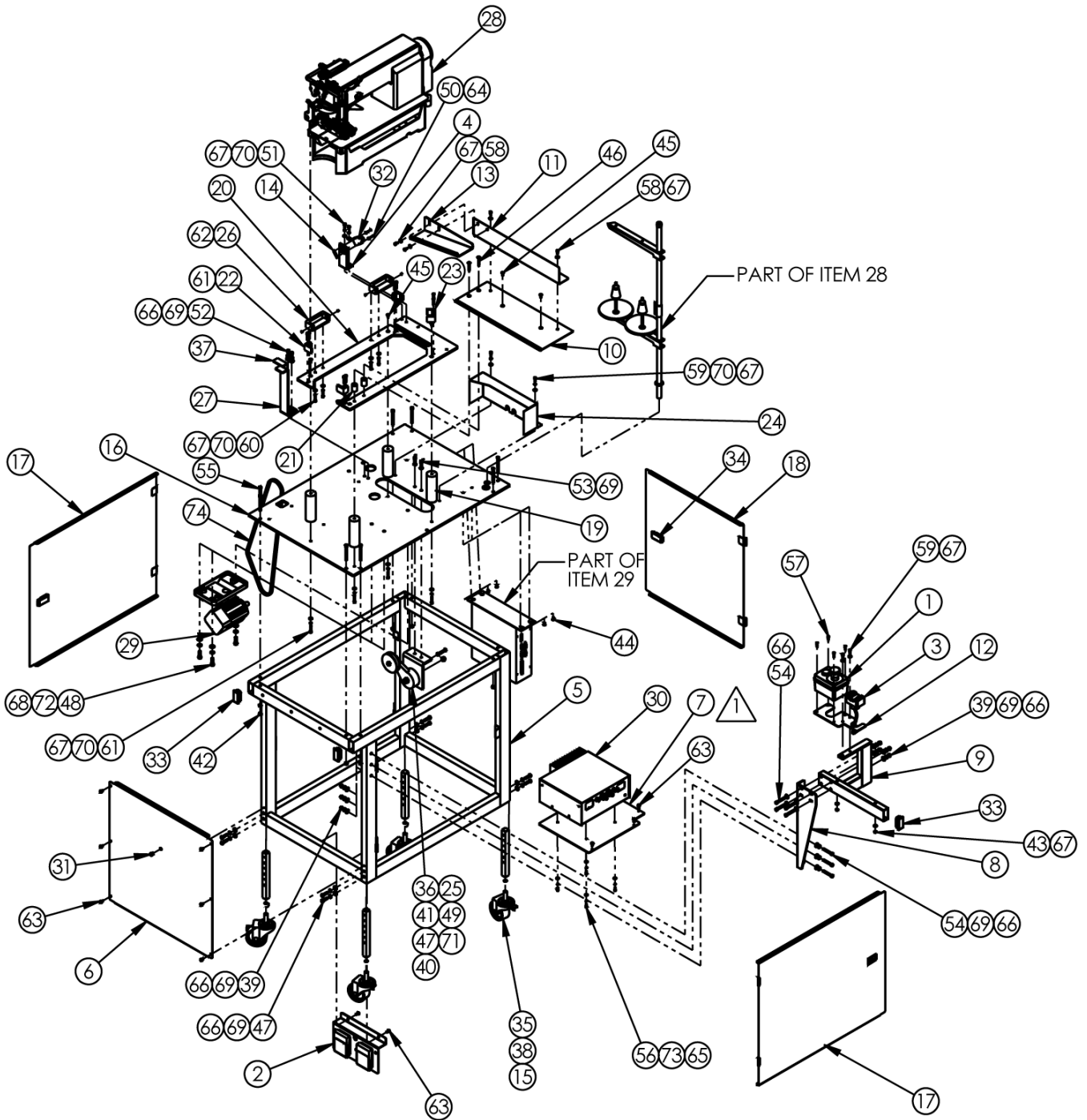

NOTES:

▲ LOCATE ITEM 7 ON TOP OF LOWER TUBES OF ITEM 5. INSTALL ITEM 62 4 PL.

1333010 Closer Station Assembly

AAC Drawing Number 1333010 Rev4

NO.	QTY	PART #	DESCRIPTION	NO.	QTY	PART #	DESCRIPTION
1	1	1278-6010	Start/Stop Button Assy	38	4	NNH1/2-13	Hex Nut
2	1	1278-6160C	Dual Foot Pedal Assy	39	7	NNH1/4-20	Hex Nut
3	1	1278-6602	Touch Switch Assy	40	3	NNH3/8-16	Hex Nut
4	1	1278-6689B	Eye Mount Brkt	41	1	NNJ1/4-20	Jam Nut
5	4	26127	Leg	42	8	NNK1/4-20	Keq Nut
6	1	1333009	Frame Assy	43	2	NNK10-32	Keq Nut
7	1	1333011	Panel	44	4	SSBC98024	Screw, Button Cap
8	1	1333012	Mount Plate	45	5	SSFC98032	Screw, Flat Allen
9	1	1333017	Mount Brkt	46	2	SSFC98096	Screw, Flat Allen
10	1	1333021	Support Weldment	47	9	SSHC01064	Screw, Hex Cap
11	1	1333022	Material Guide	48	3	SSHC10064	Screw, Hex Cap
12	1	1333023	Edge Guide	49	1	SSHC25144	Screw, Hex Cap
13	1	1333024	Mount Plate	50	2	SSPS70048	Screw, Pan Head
14	1	1975-412A	Nut Plate	51	2	SSPS98032	Screw, Pan Head
15	1	1333030	Top Guide	52	2	SSSC01032	Screw, Socket Cap
16	1	32006005	Top Plate	53	2	SSSC01048	Screw, Socket Cap
17	2	32006020	Left Rear Door	54	7	SSSC01112	Screw, Socket Cap
18	1	32006021	Right Door	55	8	SSSC01160	Screw, Socket Cap
19	4	32006501	Stand-Off	56	4	SSSC90024	Screw, Socket Cap
20	1	32006503	Top Plate	57	4	SSSC90040	Screw, Socket Cap
21	2	32006504	Spacer	58	4	SSSC98024	Screw, Socket Cap
22	3	32006505	Corner Brkt	59	4	SSSC98032	Screw, Socket Cap
23	1	32006506	Corner Brkt	60	4	SSSC98048	Screw, Socket Cap
24	1	32006512	Belt Cover	61	12	SSSC98064	Screw, Socket Cap
25	1	32006521	Idler Pulley Brkt	62	4	SSSS98016	Screw, Socket Set
26	2	32006522	Hinge Mount	63	12	SSZS93032	Screw, Sheet Metal
27	1	32006531	Tilt Support Brkt	64	2	WWF4	Flat Washer
28	1	32006600A	Sewing Head Assy	65	4	WWF8	Flat Washer
29	1	4059-DC1500FP	Motor	66	24	WWFS1/4	Flat Washer
30	1	AP-28-800WD	Stepper Box	67	20	WWFS10	Flat Washer
31	1	EESB-375-4	Heyco Bushing	68	3	WWFS5/16	Flat Washer
32	1	FFSM312LVQ	Electric Eye	69	22	WWL1/4	Lock Washer
33	3	MM132-1496	Plug	70	12	WWL10	Lock Washer
34	3	MM40450010	Slide Lock Fastener	71	1	WWL3/8	Lock Washer
35	4	MM503022LB	Caster	72	3	WWL5/16	Lock Washer
36	1	MMFS0127	Belt Tensioner	73	4	WWL8	Lock Washer
37	1	MMLSSBB01210	Foam	74	1	ZX3848	V Belt

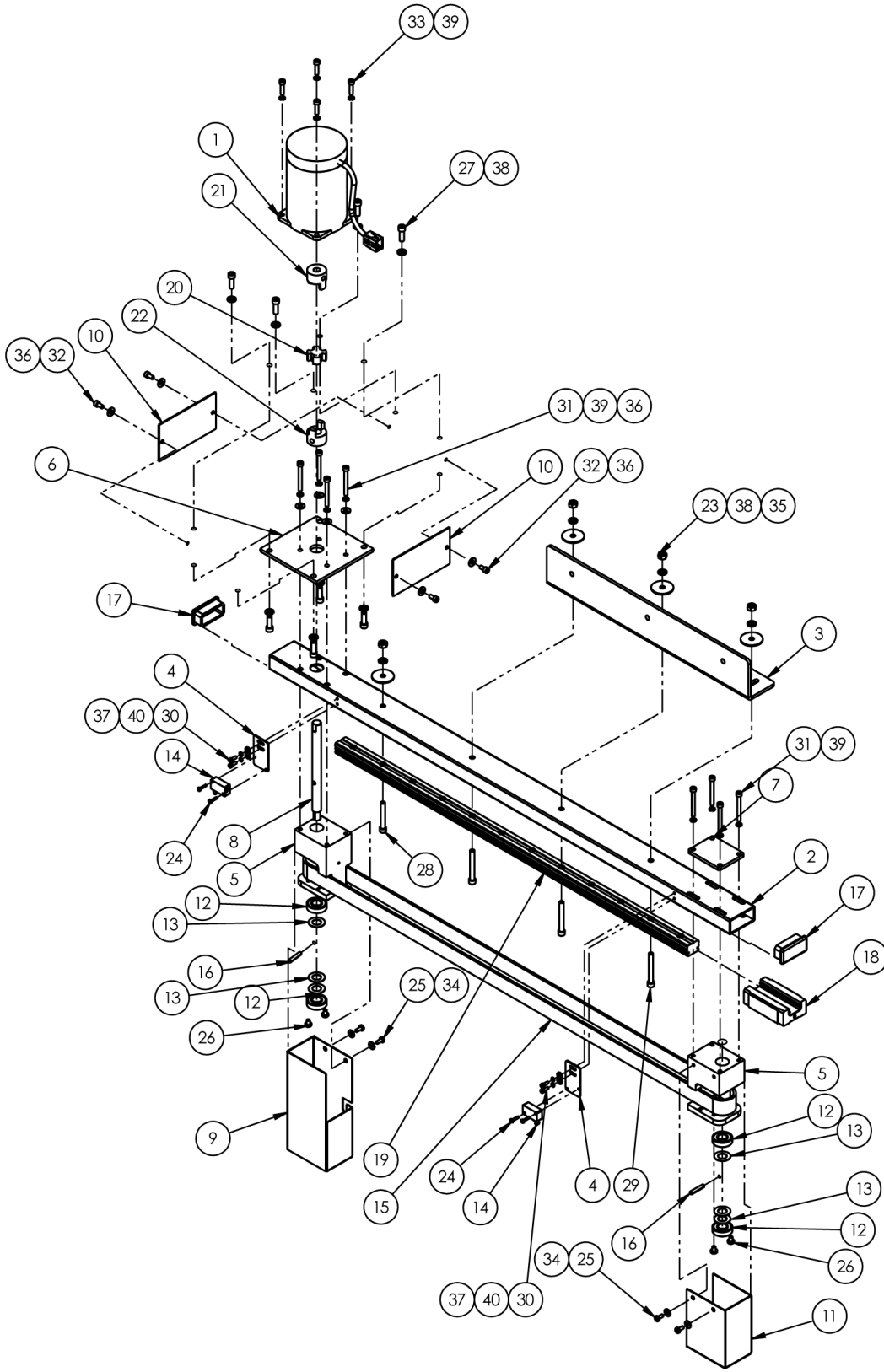

From the library of: Diamond Needle Corp

1333100 Transfer Assembly

AAC Drawing Number 1333100 Rev2

NO.	QTY	PART #	DESCRIPTION
1	1	011-020	Stepper Motor
2	1	1333101	Tube
3	1	1333112	Rail Mnt Brkt
4	2	1333113	Sensor Mnt Plate
5	2	32007605	Pulley Brkt
6	1	32007607	Motor Mnt Brkt
7	1	32007610	Backing Plate
8	1	32007615	Drive Shaft
9	1	32007645	Encoder Cover
10	2	32007646	Coupling Cover
11	1	32007658	Belt Cover
12	2	98203012	Pulley
13	1	98203013	Idler Pulley Shaft
14	2	98203015A	Motor Mnt
15	1	98203024	Motor Mnt Plate
16	4	BB1L005	Ball Bearing
17	6	BBTRA815	Thrust Washer
18	2	EEVX80C1	Switch
19	1	GG686L100ST	Gear Belt
20	2	IIS012X064	Spring Pin
21	2	MM132-1496	End Cap
22	1	MMAGH25CA	Linear Bearing
23	1	MMAGR25710	Linear Rail
24	1	MML050	Coupling Spider
25	1	MML050-375	Coupling, 3/8
26	1	MML050-500	Coupling, 1/2
27	4	NNH1/4-20	Hex Nut
28	4	SSPS70032	Screw, Pan Head
29	4	SSPS90024	Screw, Pan Head
30	4	SSPS98016	Screw, Pan Head
31	8	SSSC01048	Screw, Socket Cap
32	1	SSSC01112	Screw, Socket Cap
33	3	SSSC01128	Screw, Socket Cap
34	4	SSSC80024	Screw, Socket Cap
35	8	SSSC95112	Screw, Socket Cap
36	4	SSSC98024	Screw, Socket Cap
37	4	SSSC98048	Screw, Socket Cap
38	4	WWF6	Flat Washer
39	4	WWF8	Flat Washer
40	4	WWFE016	Fender Washer
41	8	WWFS10	Flat Washer
42	12	WWL1/4	Lock Washer
43	12	WWL10	Lock Washer
44	4	WWL6	Lock Washer

From the library of: Diamond Needle Corp

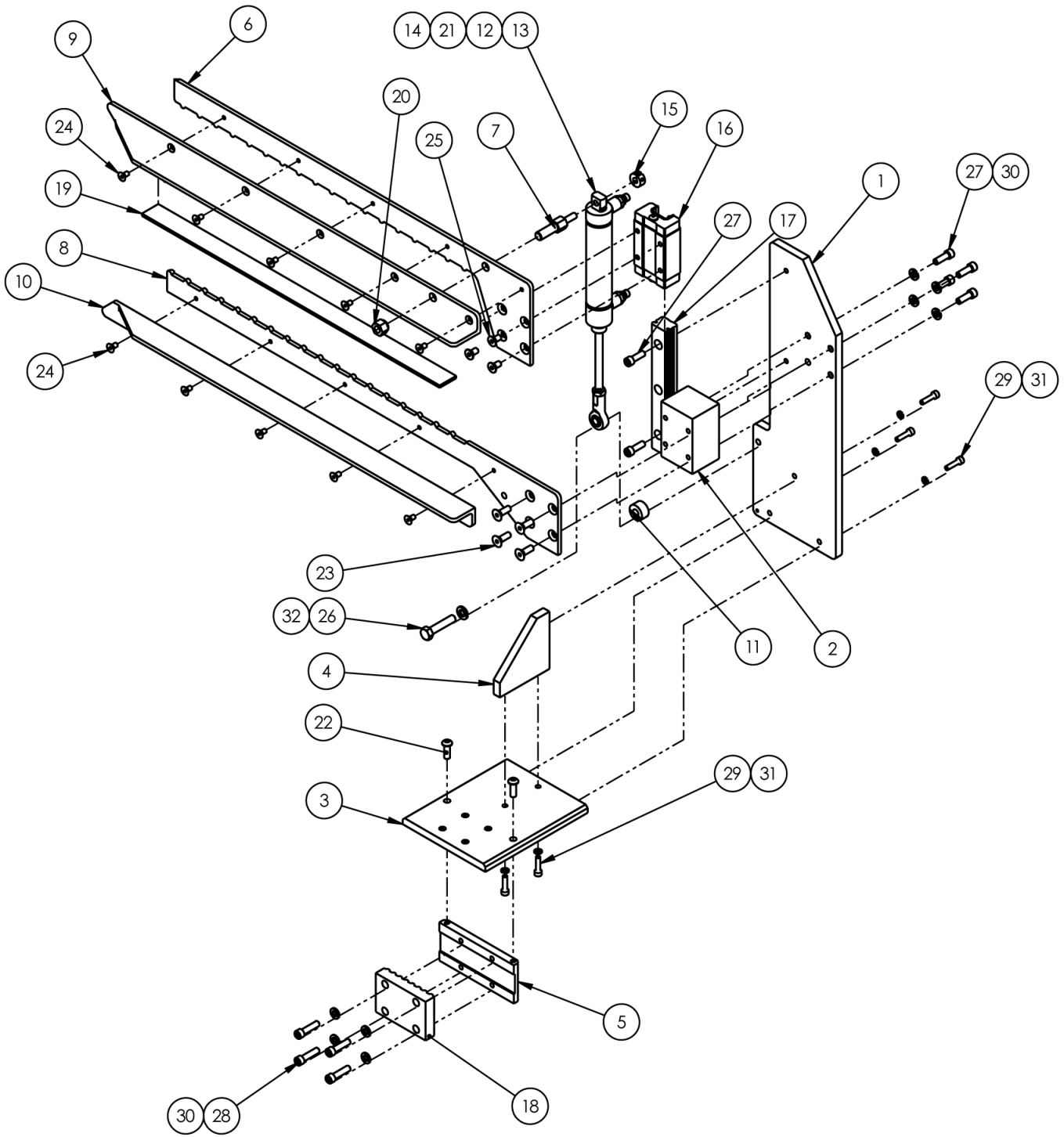

From the library of: Diamond Needle Corp

1333200 Gripper Assembly

AAC Drawing Number 1333200 Rev4

NO.	QTY	PART #	DESCRIPTION
1	1	1333201	MAIN MTG PLATE
2	1	1333202	SPACER, BOTTOM CLAMP
3	1	1333203	BASE PLATE, GRIPPER ASSY
4	1	1333204	GUSSET, MTG PLATE
5	1	32007611	BELT HOLDER
6	1	32007801	TOP CLAMP MTG PLT.
7	1	32007804	STUD, CLAMP CYLINDER
8	1	32007805	BOTTOM CLAMP MTG PLT.
9	1	32007807	CLAMP, UPPER PRIMARY
10	1	32007808	CLAMP, LOWER PRIMARY
11	1	32007829	SPACER, CYL MNT
12	2	AA198RA508	FLOW CONTROL,5/32 X 1/8"
13	1	AAC6DP-3M	CYLINDER,AIR,DA,MAG
14	1	BBAW-5Z	ROD END, SPHERICAL .5/16ID
15	1	CCCL4F	COLLAR,1/4,CLAMP
16	1	MMAGH25CAN	LINEAR BEARING
17	1	MMAGR25165N	RAIL,LINEAR,AG SERIES
18	1	MMCPL100	BELT CLAMP
19	20 *	MMLSSBB01210	FOAM, URETHANE, 1/8X1
20	1	NNE3/8-16	NUT, ELASTIC 3/8-16
21	1	NNJ5/16-24	5/16-24 HEX JAM NUT
22	2	SSBC01048	1/4-20 X 3/4 BUT HEAD
23	4	SSFC01048	1/4-20 X 3/4 FLAT ALLEN
24	10	SSFC98024	#10-32 X 3/8 FLAT ALLEN
25	4	SSFCM6X12	M6-1.0 X 12 FLAT ALLEN
26	1	SSHC10096	5/16-18 X 1-1/2 HEX HEAD
27	6	SSSC01048	1/4-20 X 3/4 SOC CAP
28	4	SSSC01064	1/4-20 X 1 SOC CAP
29	5	SSSC98048	#10-32 X 3/4 SOC CAP
30	8	WWL1/4	1/4 LW
31	5	WWL10	#10 LW
32	1	WWL5/16	5/16 LW

From the library of: Diamond Needle Corp

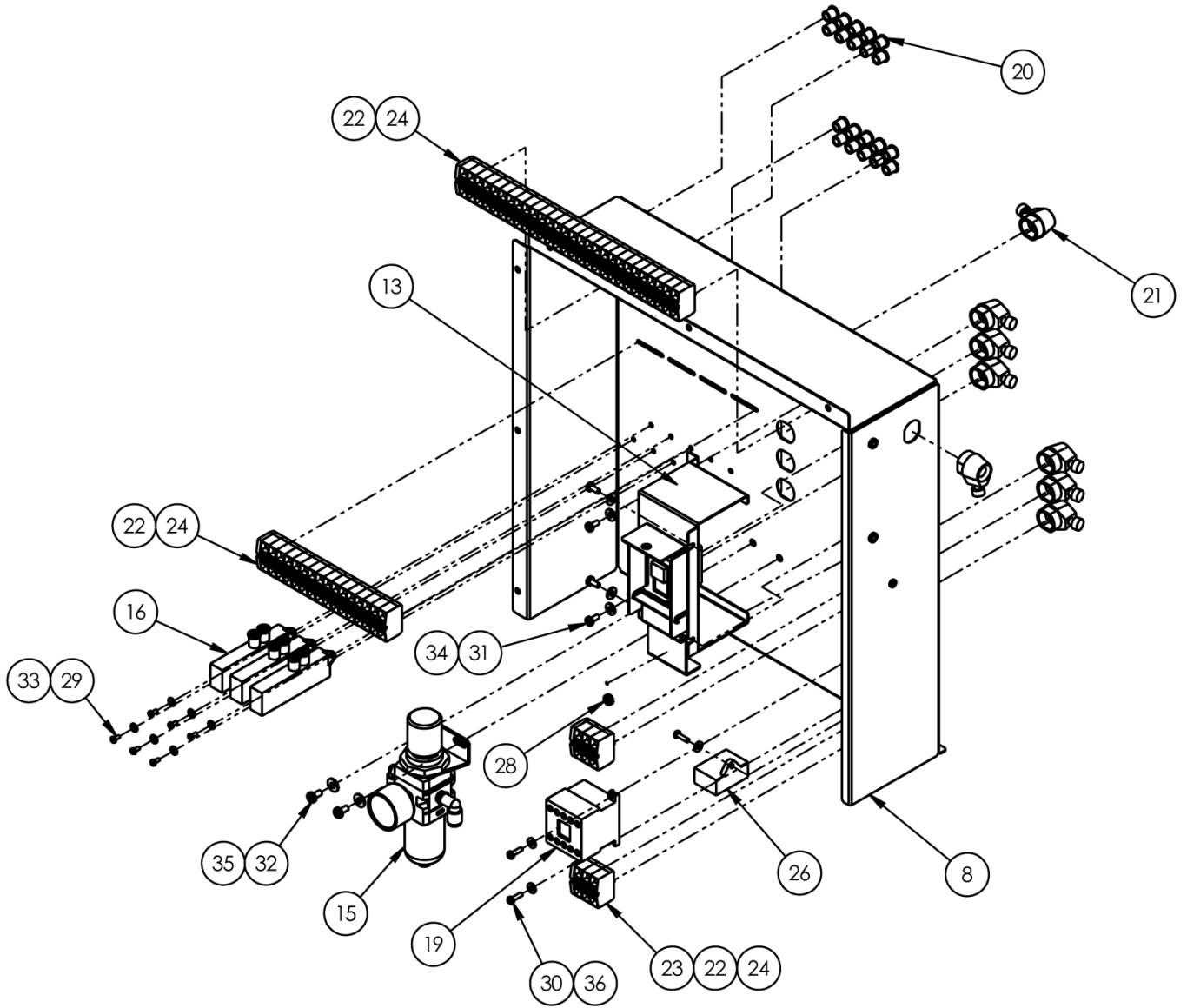

From the library of: Diamond Needle Corp

1333400 Control Panel Assembly

AAC Drawing Number 1333400 Rev1

NO.	QTY	PART #	DESCRIPTION
NS	1	0211-701N	CABLE, EFKA FP
NS	1	0211-702C	CABLE, POSITION SENSOR
NS	1	0211-703	CABLE, PULLER SYNC
NS	1	0411-1906	CABLE, PROX SWITCH, 8 FT
NS	1	0411-1927A	CABLE, FOOT PEDAL, 5 FT
NS	1	1278-7049A	CABLE, SEW HEAD, TR, REV
NS	1	12788-502B	CABLE, 4 COND, 6 FT
8	1	1333401	PANEL, CONTROL
NS	1	1335S-510	CABLE, 2P FM MOLEX
NS	1	13459009	CABLE, EXT, EFKA
NS	1	28-512A	CABLE, STEP MOTOR DRIVE
NS	2	32009002A	CABLE, EXTENSION, 3 FT
13	1	40-320	AC POWER DISCONNECT ASSY
NS	1	4080-4508A	CABLE, STEPPER MOTOR
15	1	AA198-5102	REGULATOR W/GAUGE & NUT
16	3	AAEVQZ2121	VALVE, BODY PORTED
NS	1	AP-28-610U	CABLE, JOG/DIR/ENBL
NS	1	EE17518	CORD, POWER, IEC, F
19	1	EECA491024	CONTACTOR, MINI, 240V
20	20	EESB-375-4	HEYCO BUSHING 1/4" ID
21	8	FF1724	STRAIN RELIEF
22	48	FF264-341	TERMBLK,WAGO,TOP,DUAL,GRY
23	2	FF264-347	TERMBLK,WAGO,TOP,DUAL,GRN
24	4	FF264-371	TERMBLK,WAGO,TOP,END
NS	1	FFR1K	RESISTOR, 1K, 1/4W, 5%
26	1	FFRAV781BW	MODULE, TVS, 240 VAC
NS	1	FFRK44T-4	CABLE, EYE, 12 FT, NO END
28	1	NNK8-32	KEP NUT, 8-32
29	6	SSPS70016	#4-40 X 1/4 PAN HD SLOT
30	3	SSPS80032	#6-32 X 1/2 PAN HD SLOT
31	4	SSPS90024	#8-32 X 3/8 PAN HD SLOT
32	2	SSPS98024	#10-32 X 3/8 LG. PAN HD SLOT
33	6	WWF4	WASHER, FLAT #4
34	4	WWF8	WASHER, FLAT #8
35	2	WWFS10	WASHER, FLAT #10
36	3	WWFS6	WASHER, FLAT, #6

From the library of: Diamond Needle Corp

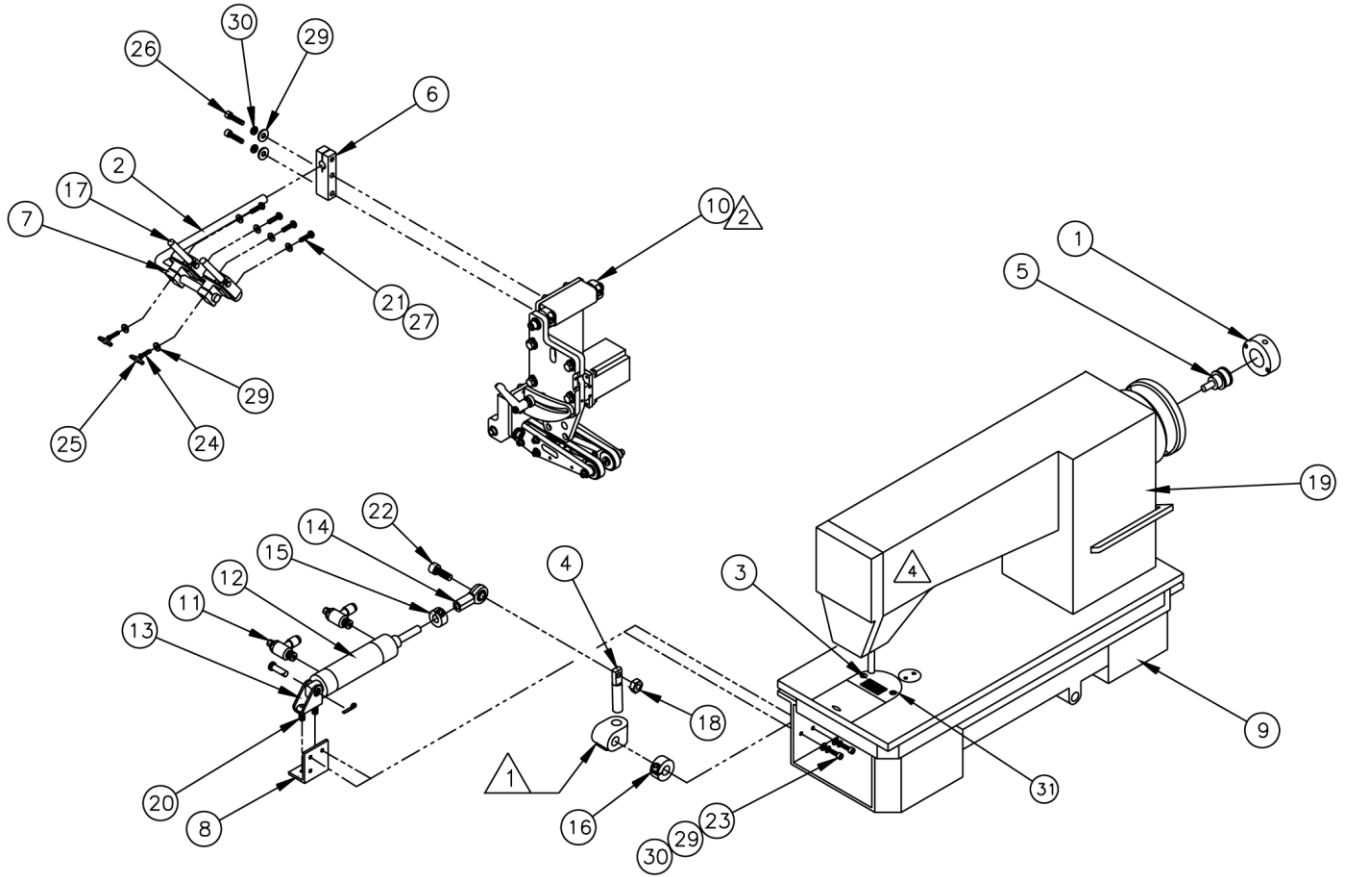

32006600A Sewing Head Assembly

AAC Drawing Number 192685C Rev5

NO.	QTY	PART #	DESCRIPTION
1	1	1278-6364	Disc, Tape Mount
2	1	1335-316	Bent Rod, 3/8
3	1	32006525	Foot
4	1	1918-073	Footlift Link
5	1	22100-013A	Sync Adapter
6	1	23080	Eye Clamp Block
7	2	23132A	Eye Holder
8	1	32006524	Pivot Mount Brkt
9	1	32006527A	Oil Tray
10	1	32007850	Pivot Assembly
11	2	AA198RA508	Flow Control
12	1	AAC6DP-1	Air Cylinder
13	1	AAFBP-11C	Pivot Brkt
14	1	BBAW-5Z	Rod End Bearing
15	1	CCCL5F	Clamp Collar
16	1	CCSCL7F	Set Collar
17	2	FFSM312LVQ	Electric Eye
18	1	NNK1/4-20	Kep Nut
19	1	SMITLS2-1380	Sewing Head
20	2	SSBC98024	Screw, Button Cap
21	4	SSPS70048	Screw, Pan Head
22	1	SSAS020032	Screw, Allen Shoulder
23	2	SSSC98024	Screw, Socket Cap
24	2	SSSC98048	Screw, Socket Cap
25	2	SSW#10	Wing Nut
26	2	SSSC98064	Screw, Socket Cap
27	4	WWF4	Flat Washer
28	1	MMF01A1419	Vibration Pad
29	6	WWFS10	Flat Washer
30	4	WWL10	Lock Washer

Page 31

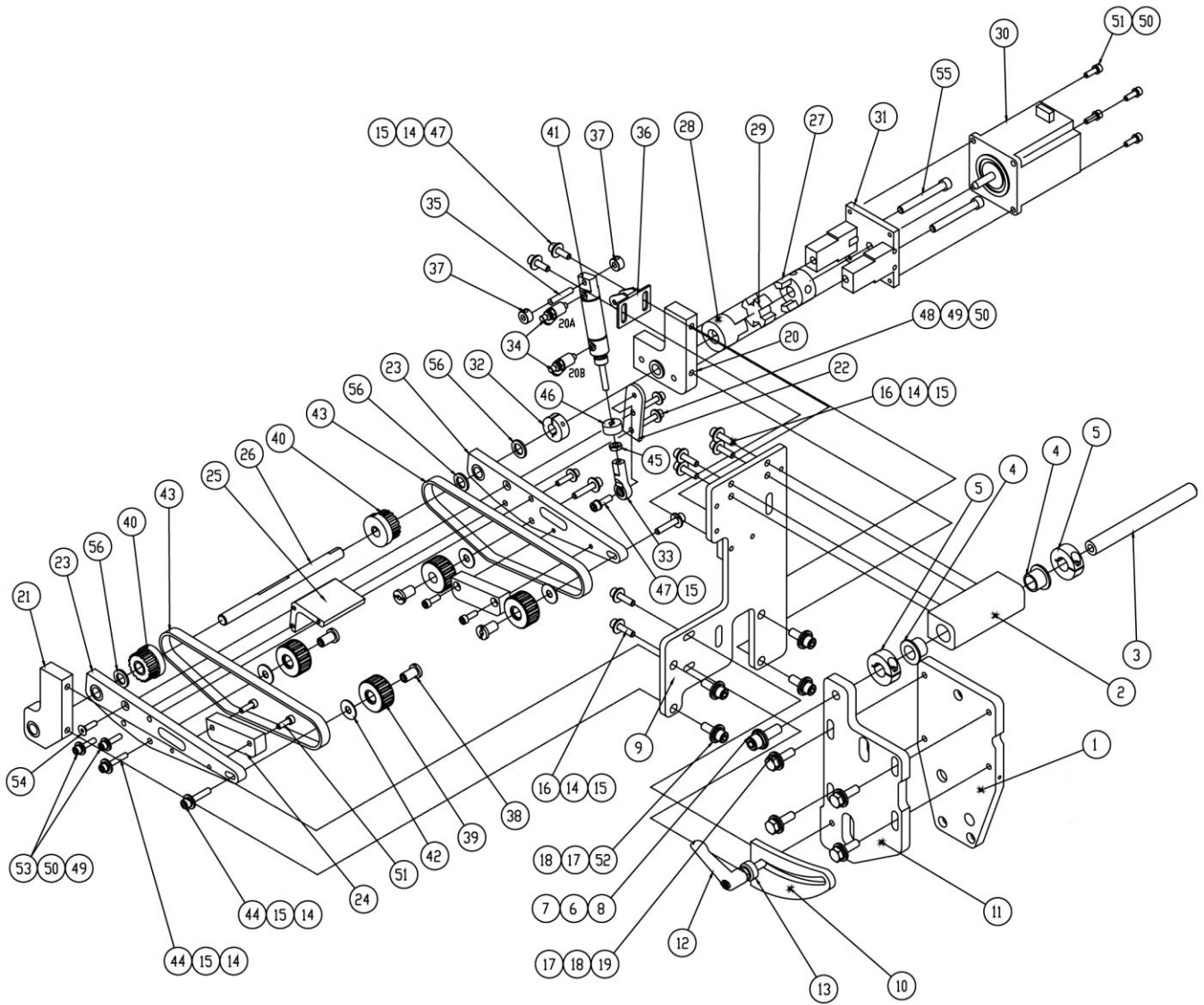

From the library of: Diamond Needle Corp

32007850 Pivot Assembly

AAC Drawing Number 32007850 Rev2

NO.	QTY	PART #	DESCRIPTION	NO.	QTY	PART #	DESCRIPTION
1	1	32007832	Pivot Adjustment Plate	29	1	MML050	Coupling Spider
2	1	32007833	Pivot Block	30	1	AP-22E-103	Stepper Motor
3	1	32007834	Pivot Shaft	31	1	AP-22E-101	Motor Brkt
4	2	UUFF620-01	Bronze Bearing	32	1	CCCL6F	Clamp Collar
5	2	CCCL8F	Clamp Collar	33	1	BBAW-3Z	Rod End Bearing
6	1	WWL5/16	Lock Washer	34	2	AA198RA510	Flow Control
7	1	WWFS5/16	Flat Washer	35	1	IID012X064	Dowel Pin
8	1	SSSC10064	Screw, Socket Cap	36	1	011-070	Cylinder Mount Plate
9	1	32007835	Mounting Plate	37	2	CCSC33/16	Set Collar
10	1	32007836	Pivot Lock Plate	38	4	26179	Pulley Bushing
11	1	32007837	Pivot Adjustment Plate	39	4	26183	Pulley
12	1	TTH32415	Theaded Handle	40	2	311-3004A	Pulley
13	1	32007838	Spacer	41	1	1975-213	Air Cylinder
14	12	WWFS10	Flat Washer	42	4	BBTRA411	Thrust Washer
15	13	WWL10	Lock Washer	43	2	GGD160XL37	Gear Belt
16	6	SSSC98048	Screw, Socket Cap	44	4	SSSC98064	Screw, Socket Cap
17	8	WWFS1/4	Flat Washer	45	1	NNJ10-32	Jam Nut
18	8	WWL1/4	Lock Washer	46	1	CCCL3F	Clamp Collar
19	4	SSHC01056	Screw, Hex Cap	47	3	SSSC98040	Screw, Socket Cap
20	1	32006550	Puller Rod Support	48	2	SSSC90064	Screw, Socket Cap
21	1	32006559	Puller Rod Support	49	6	WWF8	Flat Washer
22	1	32006552	Puller Pivot Link	50	10	WWL8	Lock Washer
23	2	32006555	Puller Arm	51	8	SSSC90032	Screw, Socket Cap
24	2	32006558	Belt Support	52	4	SSSC01048	Screw, Socket Cap
25	1	32006557	Spacer	53	3	SSSC90048	Screw, Socket Cap
26	1	32006556	Axle	54	1	SSFC90040	Screw, Flat Allen
27	1	MML050-250	Coupling, 1/4	55	2	SSSC01128	Screw, Socket Cap
28	1	MML050-375	Coupling, 3/8	56	3	BBTT604	Bronze Bearing

From the library of: Diamond Needle Corp

1333-PD Pneumatic Diagram

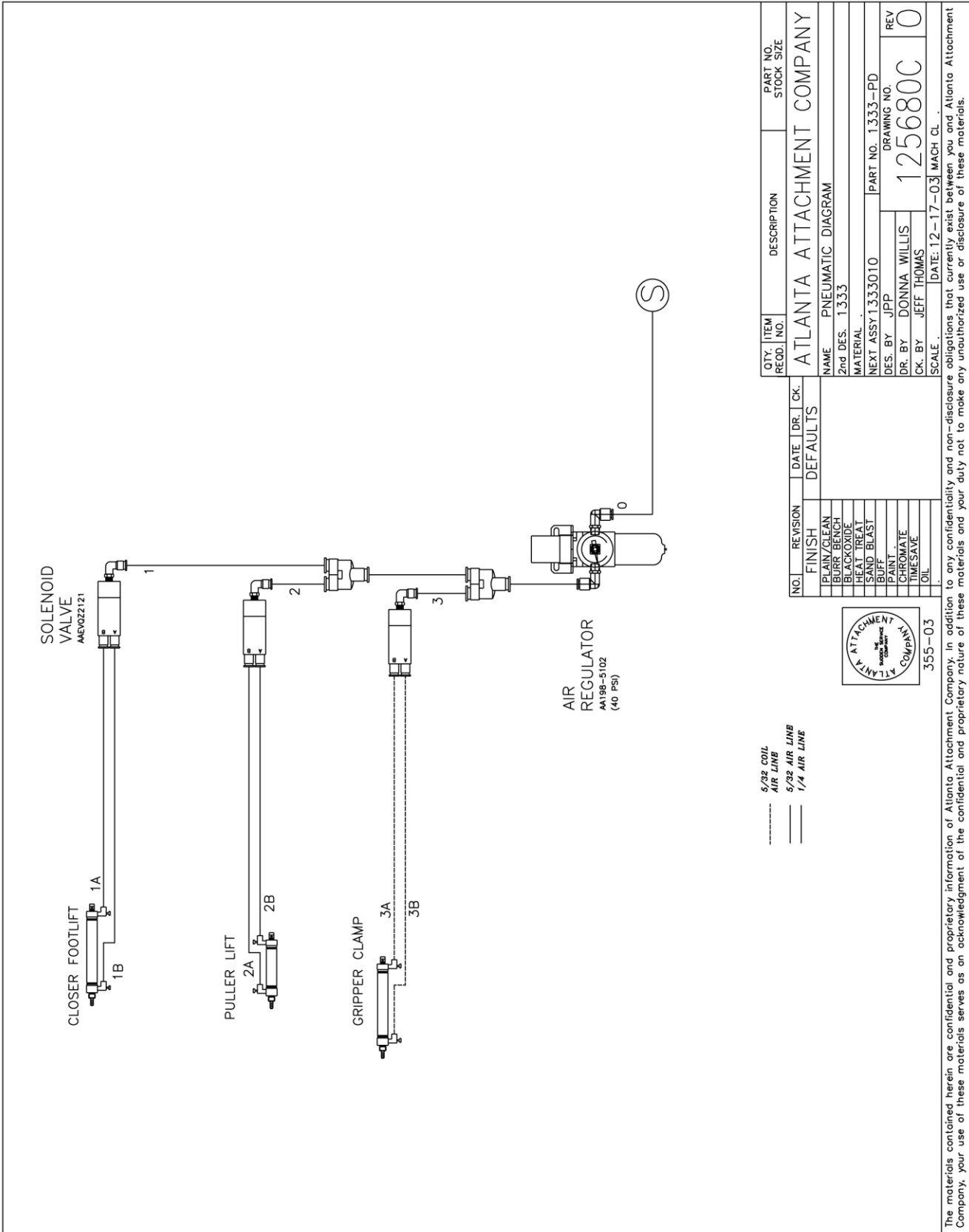

From the library of: Diamond Needle Corp

1333-WD Wiring Diagram

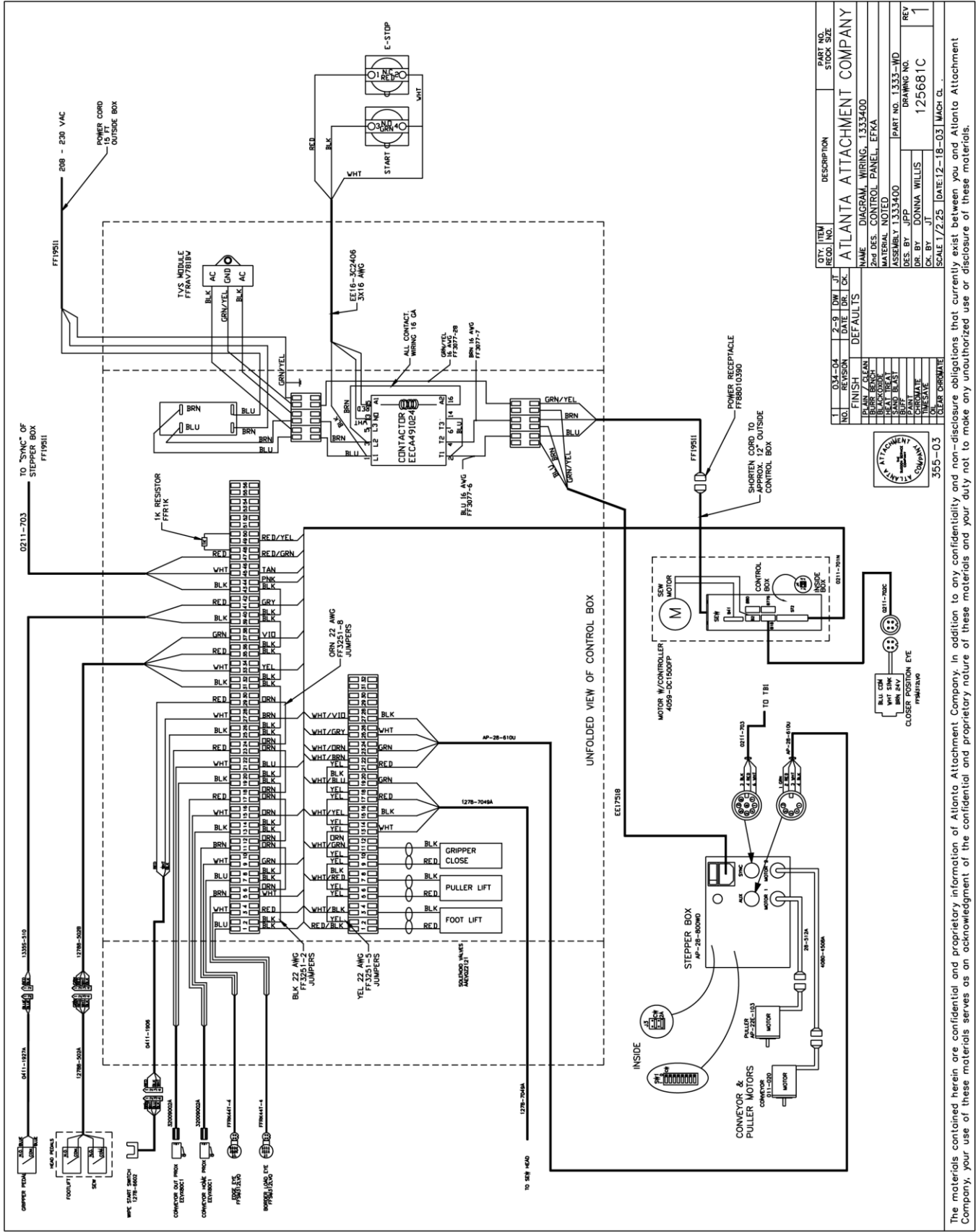

From the library of: Diamond Needle Corp

Atlanta Attachment Company (AAC) Statement of Warranty

Manufactured Products

Atlanta Attachment Company warrants manufactured products to be free from defects in material and workmanship for a period of eight hundred (800) hours of operation or one hundred (100) days whichever comes first. Atlanta Attachment Company warrants all electrical components of the Serial Bus System to be free from defects in material or workmanship for a period of thirty six (36) months.

Terms and Conditions:

- AAC Limited Warranty becomes effective on the date of shipment.
- AAC Warranty claims may be made by telephone, letter, fax or e-mail. All verbal claims must be confirmed in writing.
- AAC reserves the right to require the return of all claimed defective parts with a completed warranty claim form.
- AAC will, at its option, repair or replace the defective machine and parts upon return to AAC.
- AAC reserves the right to make the final decision on all warranty coverage questions.
- AAC warranty periods as stated are for eight hundred (800) hours or one hundred (100) days whichever comes first.
- AAC guarantees satisfactory operation of the machines on the basis of generally accepted industry standards, contingent upon proper application, installation and maintenance.
- AAC Limited Warranty may not be changed or modified and is not subject to any other warranty expressed or implied by any other agent, dealer, or distributor unless approved in writing by AAC in advance of any claim being filed.

What Is Covered

- Electrical components that are not included within the Serial Bus System that fail due to defects in material or workmanship, which are manufactured by AAC are covered for a period of eight hundred (800) hours.
- Mechanical parts or components that fail due to defects in material or workmanship, which are manufactured by AAC.
- Purchased items (sewing heads, motors, etc.) will be covered by the manufacturers (OEM) warranty.
- AAC will assist in the procurement and handling of the manufacturers (OEM) claim.

What Is Not Covered

- Parts that fail due to improper usage, lack of proper maintenance, lubrication and/or modification.
- Damages caused by; improper freight handling, accidents, fire and issues resulting from unauthorized service and/or personnel, improper electrical, plumbing connections.
- Normal wear of machine and parts such as Conveyor belts, "O" rings, gauge parts, cutters, needles, etc.
- Machine adjustments related to sewing applications and/or general machine operation.
- Charges for field service.
- Loss of time, potential revenue, and/or profits.
- Personal injury and/or property damage resulting from the operation of this equipment.

Declaración de Garantía

Productos Manufacturados

Atlanta Attachment Company garantiza que los productos de fabricación son libres de defectos de material y de mano de obra durante un periodo de ochocientos (800) horas de operación o cien (100) días cual llegue primero. Atlanta Attachment Company garantiza que todos los componentes del Serial bus son libres de defectos de material y de mano de obra durante un periodo de treinta y seis (36) meses.

Términos y Condiciones:

- La Garantía Limitada de AAC entra en efecto el día de transporte.
- Reclamos de la Garantía de AAC pueden ser realizados por teléfono, carta, fax o correo electrónico. Todo reclamo verbal tiene que ser confirmado vía escrito.
- AAC reserva el derecho para exigir el retorno de cada pieza defectuosa con un formulario de reclamo de garantía.
- AAC va, según su criterio, reparar o reemplazar las máquinas o piezas defectuosas devueltas para AAC.
- AAC reserva el derecho para tomar la decisión final sobre toda cuestión de garantía.
- Las garantías de AAC tiene una validez de ochocientas (800) horas o cien (100) días cual llega primero.
- AAC garantiza la operación satisfactoria de sus máquinas en base de las normas aceptadas de la industria siempre y cuando se instale use y mantenga de forma apropiada.
- La garantía de AAC no puede ser cambiado o modificado y no está sujeto a cualquier otra garantía implicado por otro agente o distribuidor menos al menos que sea autorizado por AAC antes de cualquier reclamo.

Lo Que Está Garantizado

- Componentes eléctricos que no están incluidos dentro del sistema Serial Bus que fallen por defectos de materiales o de fabricación que han sido manufacturados por AAC son garantizados por un periodo de ochocientas (800) horas.
- Componentes mecánicos que fallen por defectos de materiales o de fabricación que han sido manufacturados por AAC son garantizados por un periodo de ochocientas (800) horas.
- Componentes comprados (Motores, Cabezales,) son protegidos debajo de la garantía del fabricante.
- AAC asistirá con el manejo de todo reclamo de garantía bajo la garantía del fabricante.

Lo Que No Está Garantizado

- Falla de repuestos al raíz de uso incorrecto, falta de mantenimiento, lubricación o modificación.
- Daños ocurridos a raíz de mal transporte, accidentes, incendios o cualquier daño como resultado de servicio por personas no autorizados o instalaciones incorrectas de conexiones eléctricas o neumáticas.
- Desgaste normal de piezas como correas, anillos de goma, cuchillas, agujas, etc.
- Ajustes de la máquina en relación a las aplicaciones de costura y/o la operación en general de la máquina.
- Gastos de Reparaciones fuera de las instalaciones de AAC
- Pérdida de tiempo, ingresos potenciales, y/o ganancias.
- Daños personales y/o daños a la propiedad como resultado de la operación de este equipo.



From the library of: Diamond Needle Corp

Atlanta Attachment Company
362 Industrial Park Drive
Lawrenceville, GA 30046
770-963-7369
www.atlatt.com

Printed in the USA