

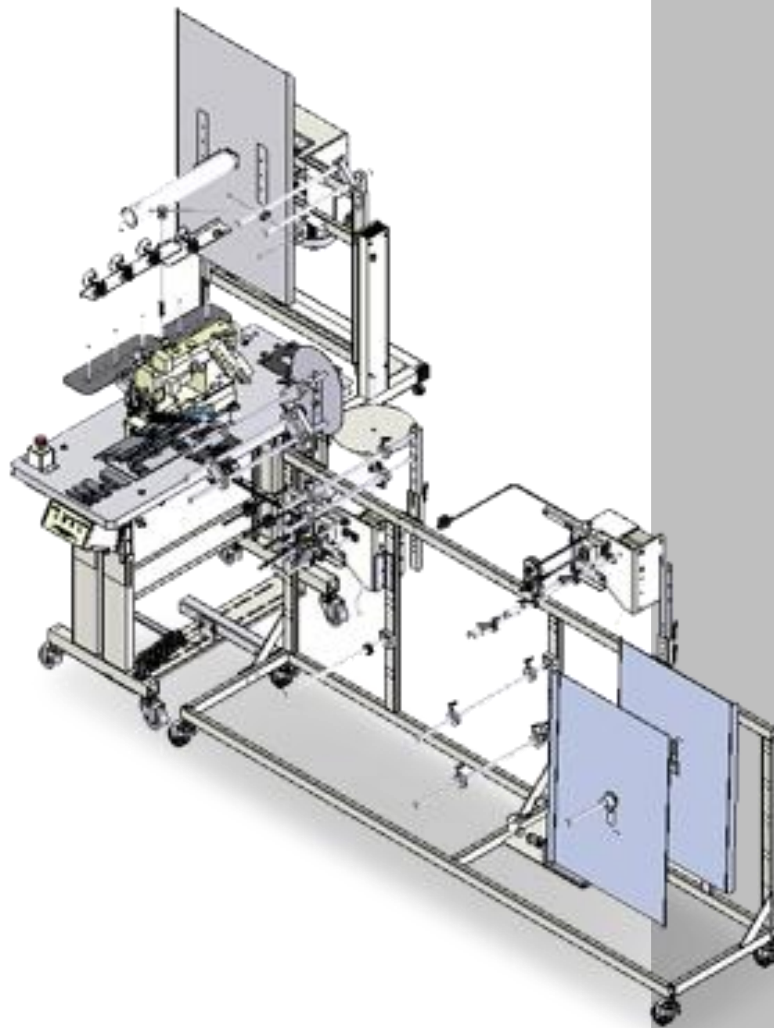

Model **1330E**

Revision 1.3 updated Jan 7, 2013

Technical Manual & Parts Lists



From the library of: Diamond Needle Corp

Atlanta Attachment Company

362 Industrial Park Drive

Lawrenceville, GA 30046

770-963-7369 • www.atlatt.com

ATLANTA ATTACHMENT COMPANY, INC.

Confidential and Proprietary Information

The materials contained herein are confidential and proprietary information of Atlanta Attachment Company. In addition to any confidentiality and non-disclosure obligations that currently exist between you and Atlanta Attachment Company, your use of these materials serves as an acknowledgment of the confidential and proprietary nature of these materials and your duty not to make any unauthorized use or disclosure of these materials.

All materials contained herein are additionally protected by United States Copyright law and may not be used, disclosed, reproduced, distributed, published or sold without the express written consent of Atlanta Attachment Company, which consent may be withheld in Atlanta Attachment Company's sole discretion. You may not alter or remove any copyright, trademark or other notice from copies of these materials.

Patents & Patents Pending

The sale of this product does not sell or otherwise transfer any license or other rights under any U.S. Patent or other corresponding foreign patent.

This equipment is manufactured under one or more of the following patents:

4,280,421 • 4,432,294 • 4,466,367 • 4,644,883 • 5,134,947 • 5,159,889 • 5,203,270 • 5,373,798 • 5,437,238 • 5,522,332 • 5,524,563 • 5,562,060 • 5,634,418 • 5,647,293 • 5,657,711 • 5,743,202 • 5,865,135 • 5,899,159 • 5,915,319 • 5,918,560 • 5,924,376 • 5,979,345 • 6,035,794 • 6,055,921 • 6,202,579 • 6,279,869 • 6,295,481 • 6,494,225 • 6,523,488 • 6,574,815 • 6,802,271 • 6,834,603 • 6,968,794 • 6,994,043 • 7,543,364 • 7,574,788 • 7,647,876 • 7,735,439

Foreign Patents: 9-520,472 • 0,537,323 • 92,905,522.6 • 96,936,922.2 • 2,076,379 • 2,084,055
Other U.S. and Foreign Patents Pending.

IMPORTANT

It is important to read and understand the information contained within this manual before attempting to operate the machine. Atlanta Attachment Co., Inc. shall not be held liable for damage resulting from misuse of the information presented within, and reserves the right to change the information contained within, without prior notification.

Contents

Important Safety Instruction	1
Liability	2
Safety Equipment on the Machines	3
Protective Eyewear	4
Important Notices.....	5
Maintenance	7
Repair	8
A Word to the End User.....	9
Safety Precautions.....	9
Assembly Drawings & Parts Lists	11
11330E Border Zipper Workstation.....	13
1330130 Roll Holder.....	15
K-4D HD T Leg Adjustment Stand	16
502-Z088A Zipper Box, 1-3/8	17
1330027 Junction Box Assembly	19
1330006 Unwinder Motor Assembly.....	21
1330110 Folder, 4-12” Adjustable.....	23
1330120 Motor Table Stand	25
1330113 Zipper Unwind W/ Pulls	27
1330200 Rewinder W/mounting Assembly.....	28
1330119 Folder Mount Assembly	29
1347098 Rewind Assembly w/Sleeve	31
785-A97-36 Stationary Disc Assembly, 36”	32
1347630 Binding Reel Assembly	33
213-005 Table Mount Button Assembly.....	34
1330160 Dual Tension Rack.....	35
1330176 Unwinder Motor Assembly.....	37
23218DM Gear Motor Assembly	38
4003-IS3WT2 Thread Break Sensor.....	40
1330-PD Pneumatic Diagram	41
1347MA-PD Pneumatic Diagram, 1347MA	42
1330-WD Wiring Diagram	43
1347MA-WD Wiring Diagram.....	44
1330E-WD Wiring Diagram.....	45

Important Safety Instruction



This part of the Instruction Material is provided for the safe use of your equipment. It contains important information to help work safely with the unit and describes the dangers inherent in machinery. Some of these dangers are obvious, while others are less evident.

Mandatory Information

All persons operating and/or working on the 1330E Border Zipper Workstation should read and understand all parts of the Safety Instructions. This applies, in particular, for persons who only operate and/or work on the unit occasionally (e.g. for maintenance and repair). Persons who have difficulty reading must receive particularly thorough instruction.

Scope of the Instruction Material

- The Instruction Material comprises:
- Safety information
- Operator Instructions
- Electrical and Pneumatic diagrams

And may also include;

- A list of recommended spare parts
- Instruction Manual(s) for components made by other manufacturers
- The layout and installation diagram containing information for installation

Intended Use

Our machines are designed and built in line with the state of the art and the accepted safety rules. However, all machines may endanger the life and limb of their users and/or third parties and be damaged or cause damage to other property, particularly if they are operated incorrectly or used for purposes other than those specified in the Instruction Manual.

Exclusion of Misuse



Non-conforming uses include, for example, using the equipment for something other than it was designed for, as well as operation without duly installed safety equipment. The risk rests exclusively with the end user.

Conforming use of the machine includes compliance with the technical data, information and regulations in all parts of the complete Instruction Material, as well as compliance with the maintenance regulations. All local safety and accident prevention regulations must also be observed.

Liability

The machine should only be operated when in perfect working order, with due regard for safety and the potential dangers, as well as in accordance with the Instruction Material. Faults and malfunctions capable of impairing safety should be remedied immediately. We cannot accept any liability for personal injury or property damage due to operator errors or non-compliance with the safety instructions contained in this booklet. The risk rests exclusively with the end user.

The Instruction Material should always be kept near the machine so that it is accessible to all concerned.

The local, general, statutory and other binding regulations on accident prevention and environmental protection must also be observed in addition to the Instruction Material. The operating staff must be instructed accordingly. This obligation also includes the handling of dangerous substances and provision/use of personal protective equipment.

The Instruction Material should be supplemented by instructions, including supervisory and notification duties with due regard for special operational features, such as the organization of work, work sequences, the personnel deployed, etc.

The personnel's awareness of the dangers and compliance with the safety regulations should be checked at irregular intervals.

Choice and Qualification of Personnel

Ensure that work on the machine is only carried out by reliable persons who have been appropriately trained for such work - either within the company, by our field staff or at our office - and who have not only been duly appointed and authorized, but are also fully familiar with the local regulations. Work on the machine should only be carried out by skilled personnel, under the management and supervision of a duly qualified engineer.

This not only applies when the machine is used for production, but also for special work associated with its operation (start-up and maintenance), especially when it concerns work on the hydraulic or electrical systems, as well as on the software/serial bus system.

Training

Everyone working on or with the machine should be duly trained and informed with regard to correct use of the safety equipment, the foreseeable dangers which may arise during operation of the machine and the safety precautions to be taken. In addition, the personnel should be instructed to check all safety mechanisms at regular intervals.

Responsibilities

Clearly define exactly who is responsible for operating, setting-up, servicing and repairing the machine. Define the responsibilities of the machine operator and authorize him to refuse any instructions by third parties if they run contrary to the machine's safety. This applies in particular for the operators of machines linked to other equipment. Persons receiving training of any kind may only work on or with the machine under the constant supervision of an experienced operator. Note the minimum age limits permitted by law.

A Word to the Operator

The greatest danger inherent in our machines: is that of fingers, hands or loose clothing being drawn into a machine by live, coasting or rotating tools or assemblies or of being cut by sharp tools or burned by hot elements.

ALWAYS BE CONSCIOUS OF THESE DANGERS!

Safety Equipment on the Machines



All machines are delivered with safety equipment, which shall not be removed or bypassed during operation.

The correct functioning of safety equipment on machines and systems should be checked every day and before every new shift starts, after maintenance and repair work, when starting up for the first time and when restarting (e.g. after prolonged shutdowns).

If safety equipment has to be dismantled for setting-up, maintenance or repair work, such safety equipment shall be replaced and checked immediately upon completing the maintenance or repair work. All protective mechanisms shall be fitted and fully operational whenever the machine is at a standstill or if it has been shut down for a longer period of time.

Damage

If any changes capable of impairing safety are observed in the machine or its mode of operation, such as malfunctions, faults or changes in the machine or tools, appropriate steps must be taken immediately, the machine switched off and a proper lockout tagout procedure followed. The machine should be examined for obvious damage and defects at least once per shift. Damage found shall be immediately remedied by a duly authorized person before resuming operation of machine.

The machine should only be operated when in perfect working order and when all protective mechanisms and safety equipment, such as detachable protective mechanisms, emergency STOP systems, etc. are in place and operational.

Faults or Errors

The machine must be switched off and all moving or rotating parts allowed to come to a standstill and secured against accidental restart before starting to remedy any faults or errors.

Signs on the Machine

Safety and danger signs on the machine should be observed and checked at regular intervals to ensure that they are complete and undamaged. They should be clearly visible and legible at all times.

Clothing, Jewelry, Protective Equipment

Long loose hair, loose-fitting clothes, gloves and jewelry, including rings, should be avoided in order to avoid injuries due to being caught, drawn in and wound up inside the machine.

Protective Eyewear

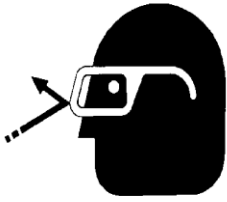

Protective eyewear that has been tested by the local authorities should be worn whenever there is a possibility of loose or flying objects or particles such as when cleaning the machine with compressed air.

Tools

Always count the number of tools in your possession before starting work on the machine. This will allow you to check that no tools have been left behind inside the machine. Never leave a tool in the machine while working.

Oils, Lubricants, Chemicals

Note the applicable safety regulations for the product used.

No Smoking, Fire, Explosion Hazard

Smoking and open flame (e.g. welding work) should be prohibited in the production area due to the risk of fire and explosions.

Workplace

A clear working area without any obstructions whatsoever is essential for safe operation of the machine. The floor should be level and clean, without any waste.

The workplace should be well lit, either by the general lighting or by local lights.

Emergency STOP

The emergency STOP buttons bring all machine movements to a standstill. Make sure you know exactly where they are located and how they work. Try them out. Always ensure easy access to the nearest emergency STOP button while working on the machine.

First Aid

1. Keep calm even when injured.
2. Clear the operator from the danger zone. The decision of what to do and whether to seek additional assistance rests entirely with you, particularly if someone has been trapped.
3. Give First Aid. Special courses are offered by such organizations as the employers' liability insurance association. Your colleagues should be able to rely on you and vice versa.
4. Call an ambulance. Do you know the telephone numbers for the ambulance service, police and fire service?

Important Notices

Reporting and Fighting Fires

Read the instructions posted in the factory with regard to reporting fires and the emergency exits. Make sure you know exactly where the fire extinguishers and sprinkler systems are located and how they are operated. Pass on the corresponding information to the firemen when they arrive. Ensure there are enough signs to avoid fire hazards.

The following fire extinguishers may be used:

- Dry powder extinguishers, ABC fire-extinguishing powder.
- Carbon dioxide fire extinguishers to DIN 14461 for electronic components. Great care must be exercised when using carbon dioxide fire extinguishers in confined, badly ventilated rooms (see DIN 14406 and 14270).

Isolate the machine from the power supply if a fire breaks out. Do not use water on burning electrical parts until it is absolutely certain that they have been completely disconnected from the power supply. Burning oils, lubricants, plastics and coatings on the machine can give off gases and vapors that may be harmful to your health.

A qualified person should be consulted to repair the damage after a fire.

Electrical Power Supply



Before undertaking any maintenance or repair work on the machine, switch off the electrical power to the machine at the main source and secure it with a padlock so that it cannot be switched on again without authorization.

In practice, this may mean that the technician, electrician and operator all attach their own padlock to the master switch simultaneously so that they can carry out their work safely. Locking extension plates should be available for multiple locks if required. The primary purpose for a lockout/tagout procedure is to protect workers from injury caused by unexpected energizing or start-up of equipment.

Energy sources (electrical/pneumatic/hydraulic, etc.) for the equipment shall be turned off or disconnected and the switches locked or labeled with a warning tag. It is the responsibility of the employer to establish control procedures. Follow lockout/tagout procedures before, setup and/or any service or maintenance work is performed, including lubrication, cleaning or clearance of jams.

Caution: The machine is still not completely de-energized even when the master switch is off.

- Electricity - The machine is always isolated from the electrical power supply whenever the master switch has been switched off. However, this does not apply for the power supply in the control cabinet, nor for equipment that does not draw its power via the master switch.
- Pneumatic / hydraulic energy - Almost all our machines carry compressed air. In addition to switching off the master switch, the air supply must also be disconnected and the machine checked to ensure it is depressurized before starting any work on the machine; otherwise the machine may execute uncontrolled movements.

- Kinetic energy - Note that some motors or spindles, for example, may continue to run or coast run on after being switched off.
- Potential energy - Individual assemblies may need to be secured if necessary for repair work.

Delivery of the Machine/Packaging

Note any markings on the packaging, such as weights, lifting points and special information. Avoid temperature fluctuations. Condensation may damage the machine.

Transport Damage

The packaging and machine must immediately be examined for signs of damage in transit. Such damage must be reported to the shipper/transporter within the applicable time limits. Contact Atlanta Attachment Company and/or your transport insurer immediately, if signs of damage are visible. Never operate a damaged machine.

Interim Storage

If the machine has to be stored temporarily, it must be oiled or greased and stored in a dry place where it is protected from the weather in order to avoid damage. A corrosion-inhibiting coating should be applied if the machine has to be stored for a longer period of time and additional precautions taken to avoid corrosion.

Transporting the Machine

Disconnect the machine from all external connections and secure any loose assemblies or parts. Never step under a suspended load. When transporting the machine or assemblies in a crate, ensure that the ropes or arms of a forklift truck are positioned as close to the edge of the crate as possible. The center of gravity is not necessarily in the middle of the crate. Note the accident prevention regulations, safety instructions and local regulations governing transport of the machine and its assemblies.

Only use suitable transport vehicles, hoisting gear and load suspension devices that are in perfect working order and of adequate carrying capacity. Transport should only be entrusted to duly qualified personnel.

Never allow the straps to rest against the machine enclosure and never push or pull sensitive parts of the machine. Ensure that the load is always properly secured. Before or immediately after loading the machine, secure it properly and affix corresponding warnings.

All transport guards and lifting devices must be removed before the machine is started up again. Any parts that are to be removed for transport must be carefully refitted and secured before the machine is started up again.

Workplace Environment

Our machines are designed for use in enclosed rooms: Permissible ambient temperature approx. 5 - 40 °C (40 - 104 °F). Malfunctions of the control systems and uncontrolled machine movements may occur at temperatures outside this range.

Protect against climatic influences, such as electrostatic charges, lightning strikes, hail, storm damage, high humidity, salinity of the air in coastal regions.

Protect against influences from the surroundings: no structure-borne vibrations, no grinding dust, or chemical vapors.

Protect against unauthorized access.

Ensure that the machine and accessories are set up in a stable position.

Ensure easy access for operation and maintenance (Instruction Manual and layout diagram); also verify that the floor is strong enough to carry the weight of the machine.

Local Regulations

Particular attention must be paid to local and statutory regulations, etc. when installing machines and the plant (e.g. with regard to the specified escape routes). Note the safety zones in relation to adjacent machines.

Maintenance

General Safety Instructions

The machine shall be switched off, come to a standstill and be secured so that it cannot be switched on again inadvertently before starting any maintenance work whatsoever. Use proper lockout/tagout procedures to secure the machine against inadvertent startup.

Remove any oil, grease, dirt and waste from the machine, particularly from the connections and screws, when starting the maintenance and/or repair work. Do not use any corrosive-cleaning agents. Use lint-free rags.

Retighten all screw connections that have to be loosened for the maintenance and repair work. Any safety mechanisms that have to be dismantled for setting-up, maintenance or repair purposes must be refitted and checked immediately after completing the work.

Maintenance, Care, Adjustment

The activities and intervals specified in the Instruction Manual for carrying out adjustments, maintenance and inspections must be observed and parts replaced as specified.

All hydraulic and pneumatic lines should be examined for leaks, loose connections, rubbing and damage whenever the machine is serviced. Any defects found must be remedied immediately.

Waste, Disassembly, Disposal

Waste products should be cleared from the machine as soon as possible as not to create a fire hazard. Ensure that fuels and operating lubricants, as well as replacement parts are disposed of in a safe and ecologically acceptable manner. Note the local regulations on pollution control.

When scrapping (disassembling) the machine and its assemblies, ensure that these materials are disposed of safely. Either commission a specialist company familiar with the local regulations or note the local regulations when disposing of these materials yourself. Materials should be sorted properly.

Repair

Replacement Parts

We cannot accept any liability whatsoever for damage due to the use of parts made by other manufacturers or due to unqualified repair or modification of the machine.

Repair, Electrical

The power supply must be switched off (master switch off) and secured so that it cannot be switched on again inadvertently before starting any work on live parts.

Those parts of the machine and plant on which inspection, maintenance or repair work is to be carried out must be isolated from the power supply, if specified. The isolated parts must first be checked to determine that they are truly de-energized before being grounded and short-circuited. Adjacent live parts must also be isolated.

The protective measures implemented (e.g. grounding resistance) must be tested before restarting the machine after all assembly or repair work on electric parts.

Signal generators (limit switches) and other electrical parts on the safety mechanisms must not be removed or bypassed. Only use original fuses or circuit overloads with the specified current rating. The machine must be switched off immediately if a fault develops in the electrical power supply.

The electrical equipment of our machines must be checked at regular intervals and any defects found must be remedied immediately.

If it is necessary to carry out work on live parts, a second person should be on hand to operate the emergency OFF switch or master switch with voltage release in the event of an emergency. The working area should be cordoned off and marked by a warning sign. Only use electrically insulated tools.

Ventilation/Hazardous Gases

It is the end users responsibility to ensure adequate ventilation is provided to exhaust any and all noxious or hazardous gases that may be present in the working environment.

Hydraulic and Pneumatic Systems

Work on hydraulic or pneumatic equipment shall only be carried out by persons with training, knowledge and experience of hydraulic systems. Pressure lines shall be depressurized before starting any repair work.

General Liability

Liability for machine damage and personal injury is extinguished completely if any unauthorized conversions or modifications are undertaken. The machine must not be modified, enlarged or converted in any way capable of affecting safety without the manufacturer's prior approval.

Starting Machine Movements

Read the Instruction Manual carefully to establish which keys and functions start machine movements.

A Word to the End User

The end user has sole responsibility to enforce the use of safety procedures and guards on the machine. Any other safety devices or procedures due to local regulations should be should be retrofitted in accordance to these regulations and/or the EC Directive on the safety of machines.

Operator's position must always be readily accessible. Escape routes must always be kept clear and safety areas should be identified.

Safety Precautions

Safety should be a constant concern for everyone. Always be careful when working with this equipment. While normal safety precautions were taken in the design and manufacture of this equipment, there are some potential safety hazards.

Everyone involved with the operation and maintenance of this equipment should read and follow the instructions in this manual.

Operate the equipment only as stated in this manual. Incorrect use could cause damage to the equipment or personal injury.

It is the owner's responsibility to make certain that the operator reads and understands this manual before operating this equipment. It is also the owner's responsibility to make certain that the operator is a qualified and physically able individual, properly trained in the operation of this equipment.

Specific safety warning decals are located on the equipment near the immediate areas of potential hazards. These decals should not be removed or obliterated. Replace them if they become non-readable.

- ALWAYS keep safety shields and covers in place, except for servicing.
- ALWAYS operate equipment in daylight or with adequate working lights.
- Follow daily and weekly checklists, making sure hoses are tightly secured and bolts are tightened.
- ALWAYS watch and avoid holes or deep depressions.
- ALWAYS wear adequate eye protection when servicing the hydraulic system and battery.
- NEVER operate a poorly maintained machine.
- NEVER allow persons to operate this machine without proper instruction.
- NEVER put hands or feet under any part of the machine while it is running.
- NEVER attempt to make any adjustments or repairs to the machine while running. Repairs or maintenance should be performed by trained personnel only.
- NEVER work under the machine unless it is safely supported with stands, blocks or a hoist and blocks.
- NEVER touch hot parts of machine.

Assembly Drawings & Parts Lists

The materials contained herein are confidential and proprietary information of Atlanta Attachment Company. In addition to any confidentiality and non-disclosure obligations that currently exist between you and Atlanta Attachment Company, your use of these materials serves as an acknowledgment of the confidential and proprietary nature of these materials and your duty not to make any unauthorized use or disclosure of these materials.



One-Stop Shopping
For Expendable Replacement Parts for AAC & Other Bedding Equipment Suppliers
Toll Free: **1-866-885-5100**
www.atlantapartsdepot.com • sales@atlantapartsdepot.com

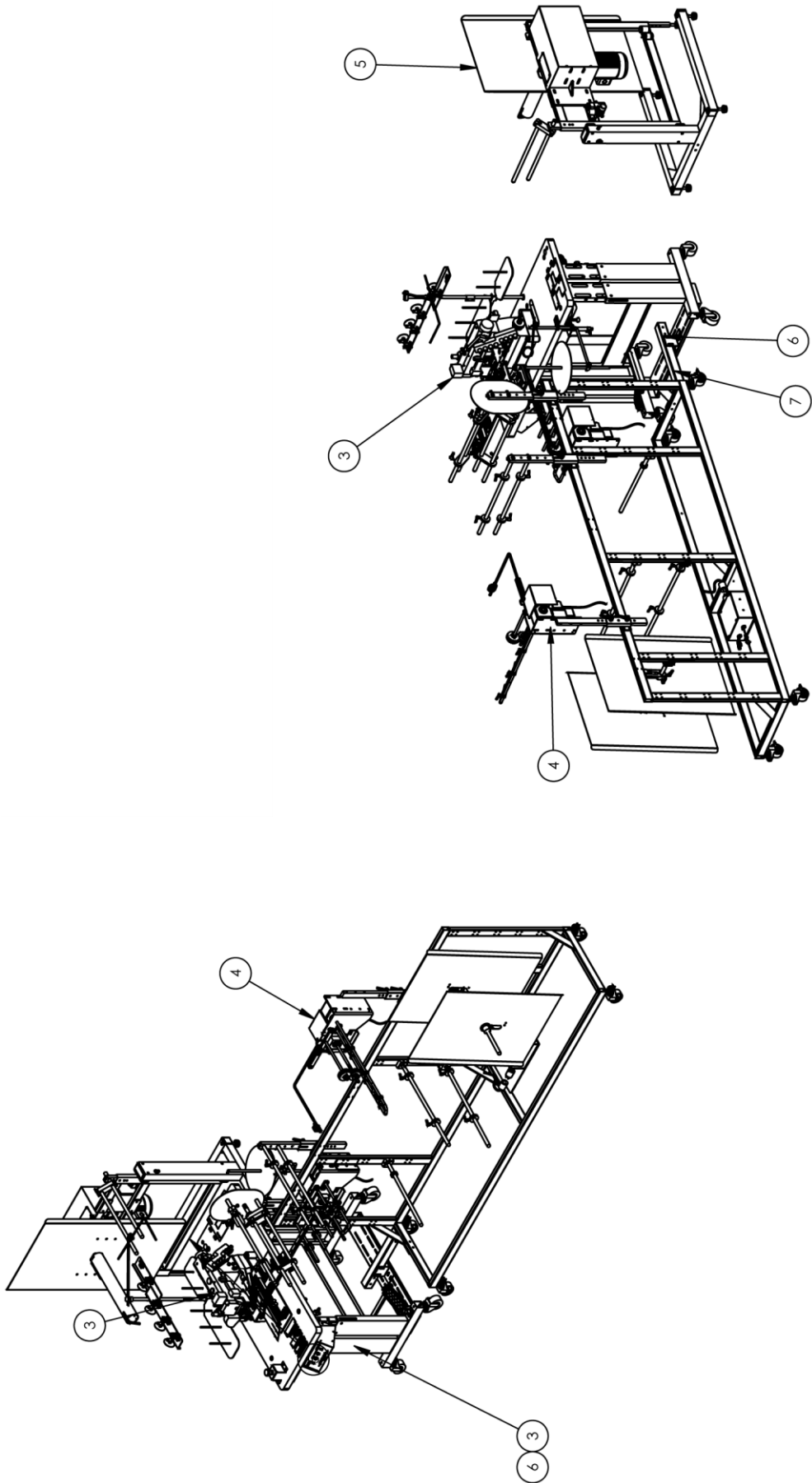

11330E Border Zipper Workstation

AAC Drawing Number 9004279 Rev 0

NO.	QTY	PART #	DESCRIPTION	
1	AR	1330-PD	DIAGRAM, PNEUMATIC	Page 41
2	AR	1330-WD	DIAGRAM, WIRING	Page 43
3	1	1330120	TABLE, STAND, MOTOR	Page 25
4	1	1330130	ROLL HOLDER	Page 15
5	1	1330200	REWINDER W/MOUNTING ASSY	Page 28
6	2	1330215	BRACE, FRAME	
7	1	1330212	BRACE FRAME ASSY.	
8	1	1330E-WD	DIAGRAM, WIRING	Page 45

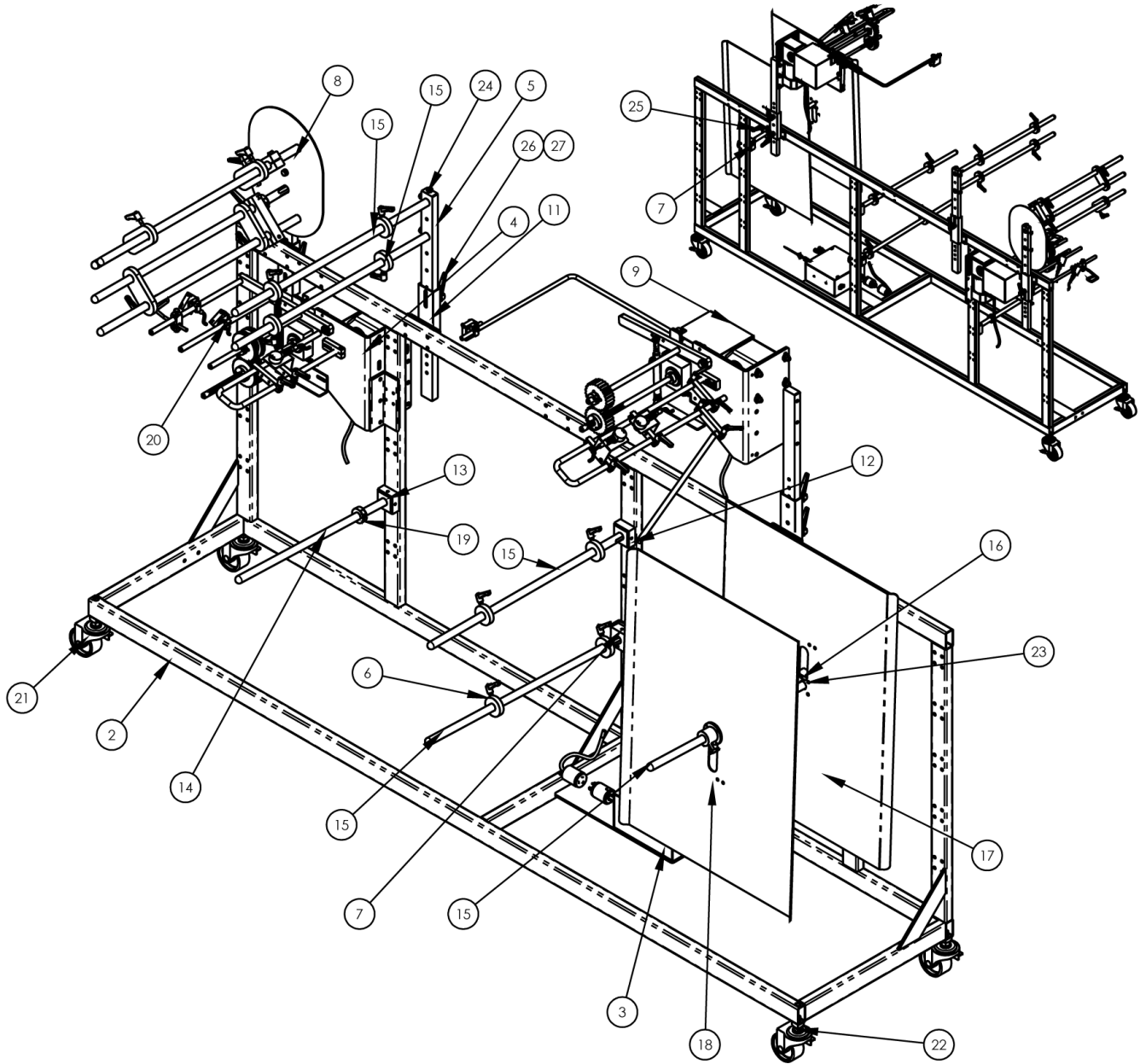

1330130 Roll Holder

AAC Drawing Number 1330130 Rev 2

NO.	QTY	PART #	DESCRIPTION	
1	2	1330-001	CABLE,"Y" ADAPTOR,4 PIN	
2	1	1330012	FRAME WELDMENT, 4 ROLL	
3	1	1330027	JUNCTION BOX ASSEMBLY	Page 19
4	1	1330113	UNWINDER, ZIPPER W/PULLS	Page 27
5	1	1330138	SUPPORT, TENSIONER,DUAL	
6	8	1330153	EDGE GUIDE, 2"X3/4B	
7	2	1330155	ROD MOUNT, 3/4B, W/SWITCH	
8	1	1330160	TENSION RACK, DUAL	Page 35
9	1	1330176	MOTOR ASY, UNWINDER	Page 37
10	1	1330E-WD	DIAGRAM, WIRING	Page 45
11	1	1347093	SUPPORT, TENSIONER	
12	1	1961-251A	HUB, UNWIND SHAFT	
13	1	1961-251C	HUB, UNWIND SHAFT	
14	1	1961-252	ROD,ROLL,SST,3/4X21 W/RAD	
15	5	1961-252D	ROD, ROLL, 27" L	
16	1	1961-253A	HUB, UNWIND STAND	
17	1	784B-2436	PLATE, ALU, 23.75 X 31.75	
18	1	785-A97-36	DISC ASBLY, 36" X 3/4 HUB	Page 32
19	1	CCCL12F	CLAMP COLLAR- 3/4	
20	5	FFRK44T-4	CABLE,EYE,12',NO END	
21	4	MM503022LB	CASTER, 3" LOCKING	
22	4	NNH1/2-13	NUT,HEX,1/2-13	
23	4	SSFC80016	6-32 X 1/4 FLAT SOC CAP	
24	4	SSH10048	5/16-18 X 3/4 HHCS	
25	2	TTH32416	HANDLE,THRD,1/4-20X1-1/8	
26	1	TTH32425	HANDLE,THRDED,5/16-18X3/4	
27	1	WWFS5/16	WASHER,FLAT,SAE,5/16	

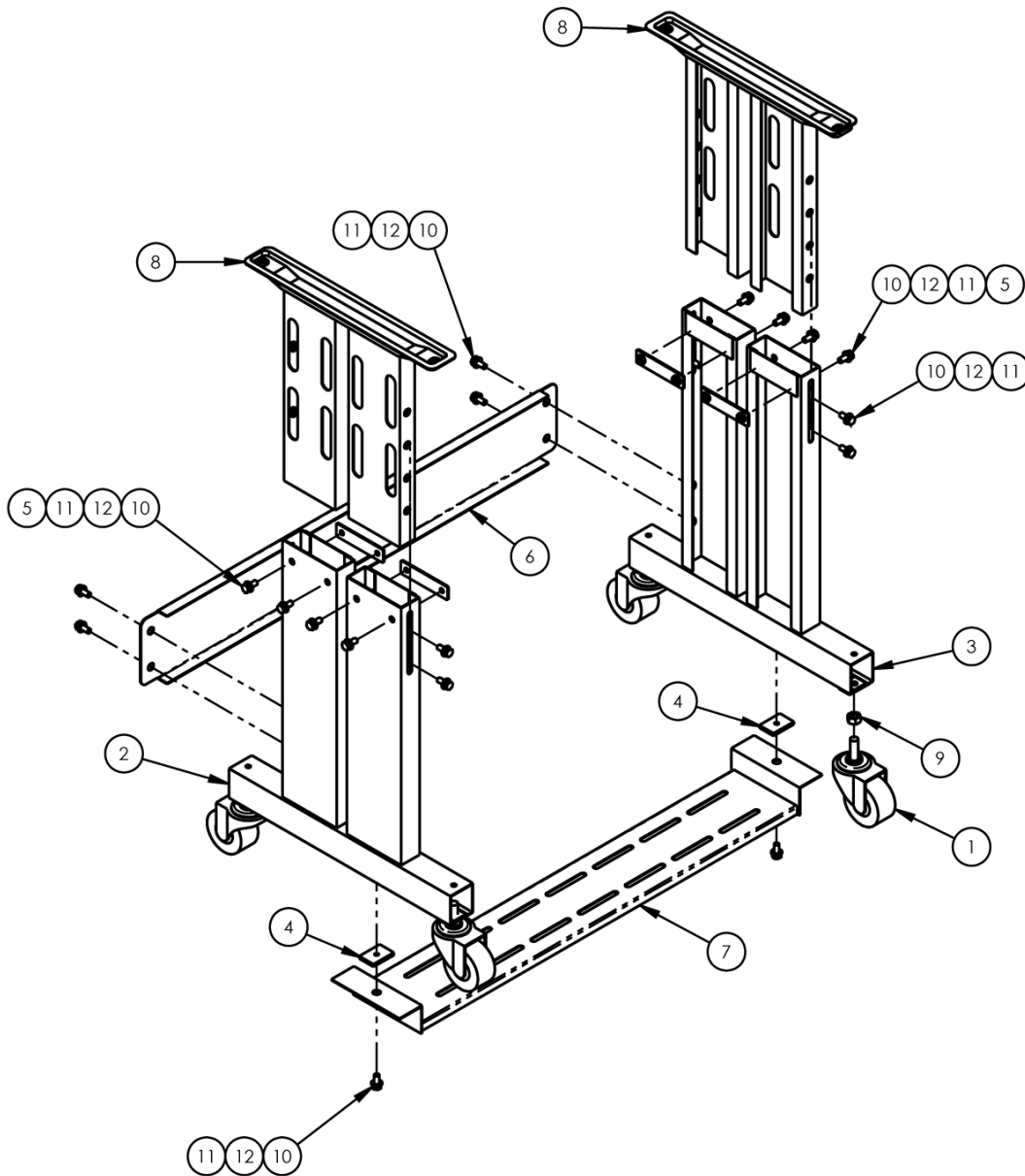

From the library of: Diamond Needle Corp

K-4D HD T Leg Adjustment Stand

AAC Drawing Number 9000401 Rev 4

NO.	QTY	PART #	DESCRIPTION
1	4	K-4D Caster	CASTER, 3" LOCKING
2	1	K-4D Lower Leg Left	LOWER LEG,LEFT
3	1	K-4D Lower Leg Right	LOWER LEG,RIGHT
4	2	K-4D Nut Plate	NUT PLATE, TREADLE
5	4	K-4D NUT PLATE_A	SIDES
6	1	K-4D Rear Brace	REAR BRACE
7	1	K-4D Treadle Mount	Treadle Mount
8	2	K-4D Upper Leg	UPPER LEG
9	4	NNHM12X1.75	NUT,HEX,M12

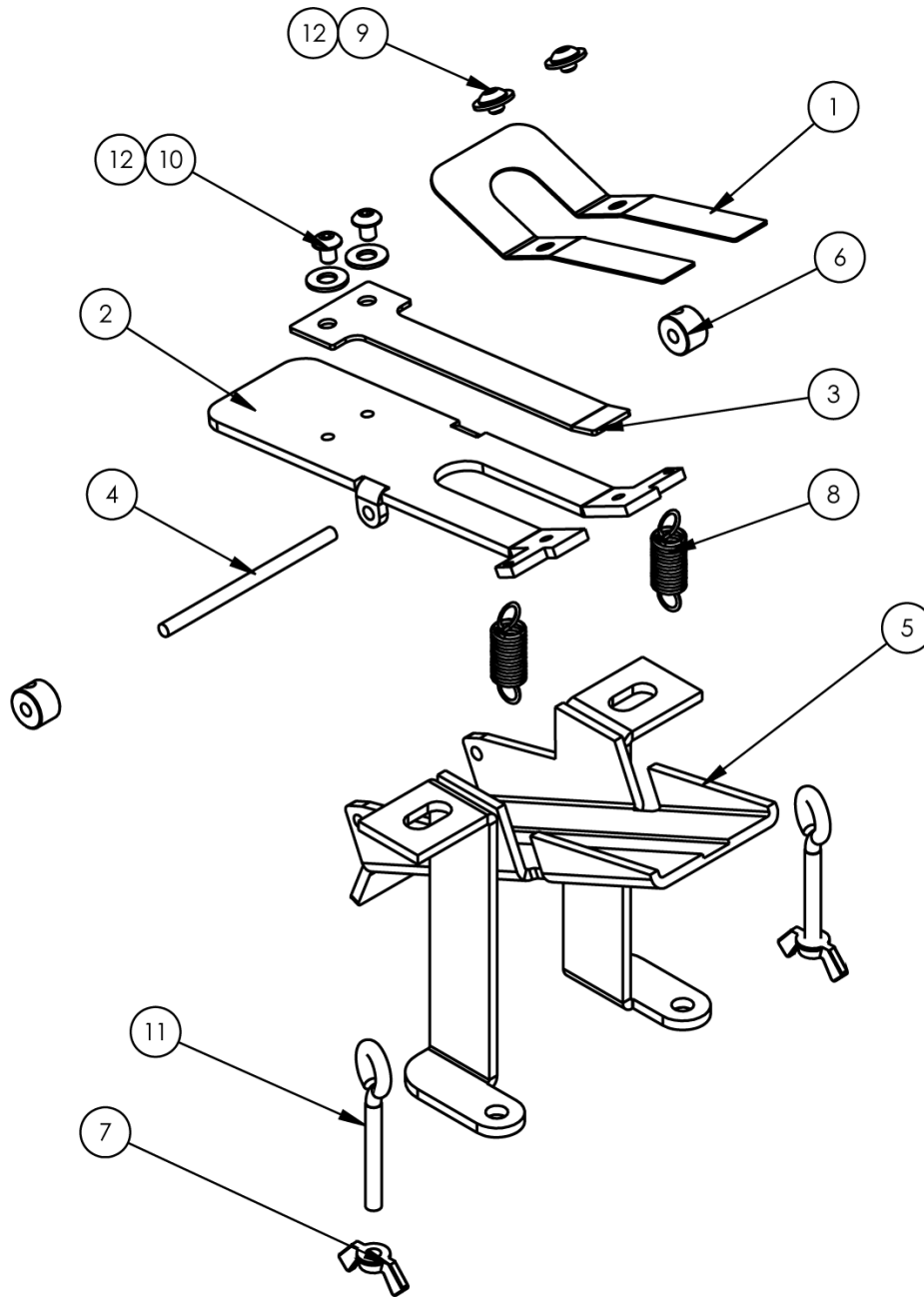

From the library of: Diamond Needle Corp

502-Z088A Zipper Box, 1-3/8

AAC Drawing Number 9004294 Rev 0

NO.	QTY	PART #	DESCRIPTION	NO.	QTY	PART #	DESCRIPTION
1	1	502Z2-008C	TENSIONER, SPRING, 1-3/8"	7	2	NNW8-32	#10-32 WING NUT
2	1	502Z2-008D	TENSION BOX BOTTOM	8	2	RRLE037CD2	SPRING,EXT,.037X.31X1.12
3	1	502Z2-008F	TONGUE, SPRING, 1-3/8"	9	2	SSBC80008	6-32 X1/8 BHCS
4	1	502Z2-008J	PIN, 1/8 X 2-1/8 S/S	10	2	SSBC80012	6-32X 3/16 BHCS
5	1	502Z2-088A	ZIPPER BOX BASE	11	2	SSBE90064	EYEBOLT,8-32X1
6	2	CCSC21/8	COLLAR,SET,1/8	12	4	WWB5/32	WASHER, FLAT, 5/32", BRAS

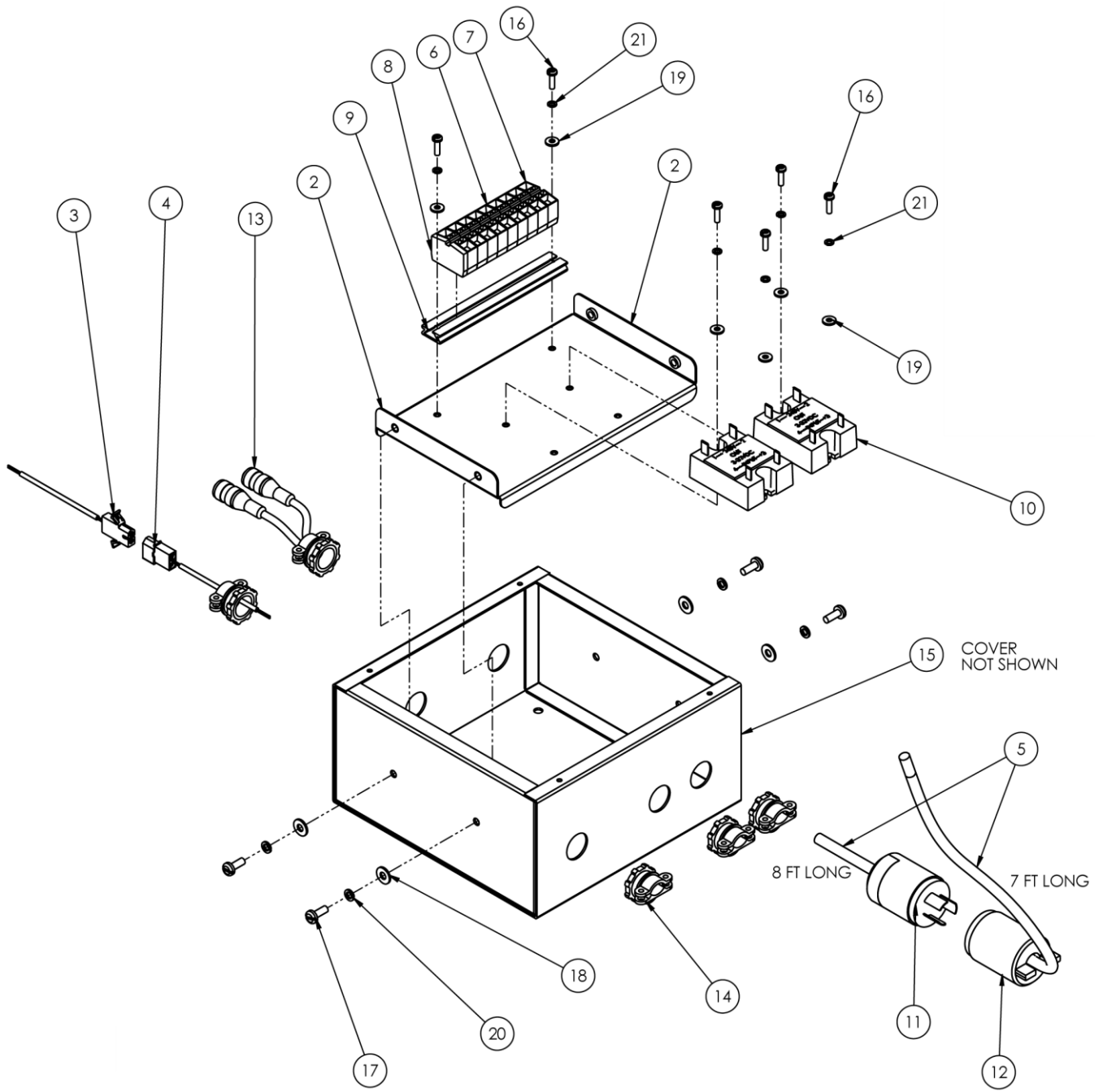

1330027 Junction Box Assembly

AAC Drawing Number 1330027 Rev 1

NO.	QTY	PART #	DESCRIPTION
1	*AR	1330-WD	WIRING DIAGRAM
2	1	1330028	MOUNT, WAGO & RELAY
3	1	1335S-510	CABLE, 2 PIN FM MOLEX
4	1	4080-4219	CABLE, UNWINDER 24vDC
5	*15'	FF19509	CABLE, 3 COND, 18 AWG, SJTOW
6	8	FF264-341	TERMBLK, WAGO, TOP, DUAL, GRY
7	1	FF264-347	TERMBLK, WAGO, TOP, DUAL, GRN
8	1	FF264-371	TERMBLK, WAGO, TOP, END
9	1	FF264-3BKT5	MOUNT, WAGO, 9 DBLS
10	2	FFD2425F	RELAY, SSR, 24VAC, 25A
11	1	FFHBL4570C	PLUG, 2P/3W, GROUNDING
12	1	FFHBL4579C	RECEPTACLE, 3 POLE, 3W
13	2	FFRK44T-4	CABLE, EYE, 12', NO END
14	5	K-235	CONNECTOR, ROMEX, 1/2"
15	1	K-SC884M	8X8X4 JUNCTION BOX, MOD
16	6	SSPS80032	#6-32 X 1/2 PAN HD SLOT
17	4	SSPS98032	#10-32 X 1/2 PAN HD SLOT
18	4	WWFS10	WASHER, FLAT #10
19	6	WWFS6	WASHER, FLAT, #6
20	4	WWL10	#10 LW
21	6	WWL6	WASHER, LOCK, 6

Page 43

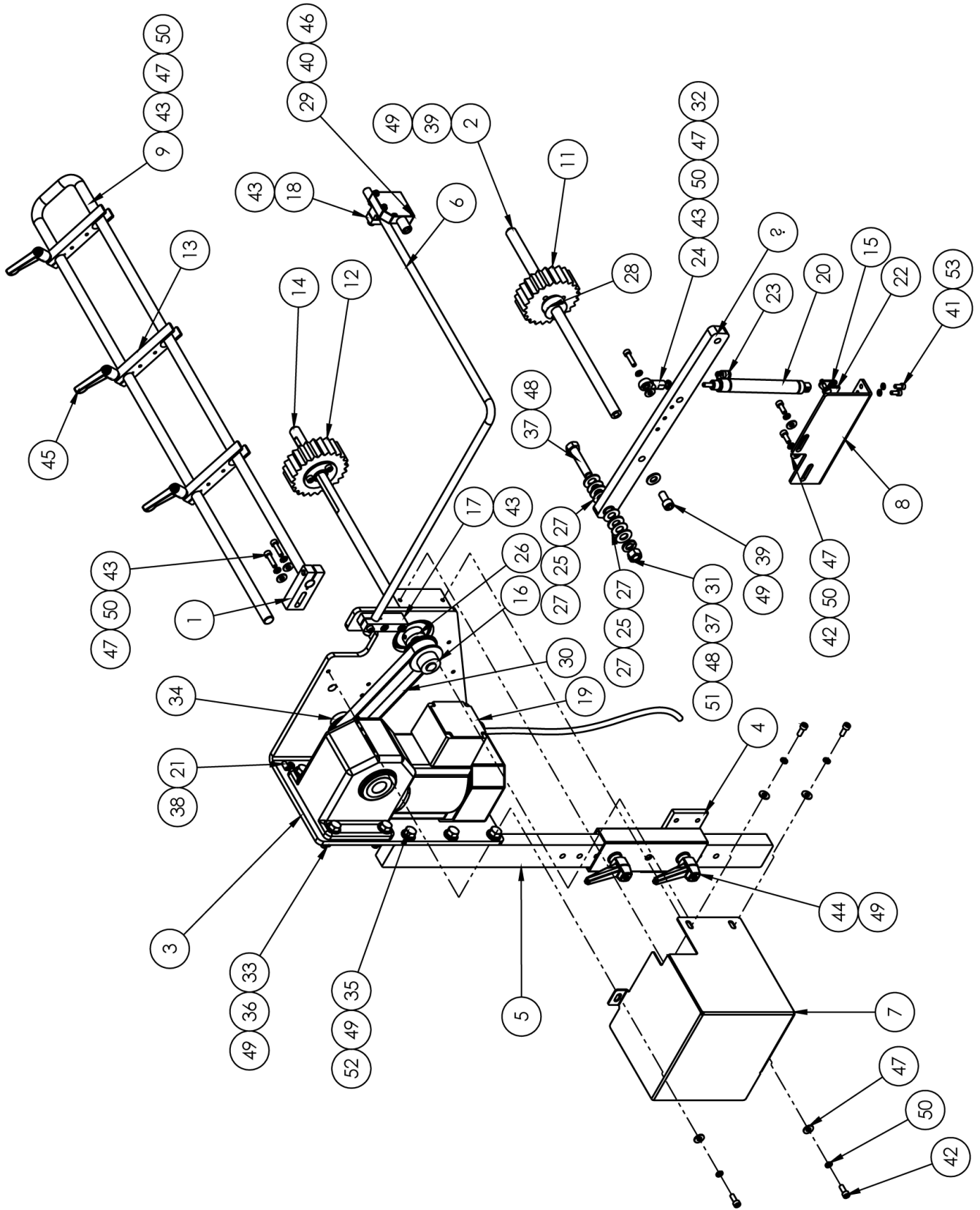

1330006 Unwinder Motor Assembly

AAC Drawing Number 1330006 Rev 2

NO.	QTY	PART #	DESCRIPTION	NO.	QTY	PART #	DESCRIPTION
1	1	1325-346	HOLDER,ROD,1/2 D,SLOT MNT	28	2	CCCL8F	CLAMP COLLAR- 1/2
2	1	1330017	SHAFT, IDLER ROLLER	29	1	FFQM42VN6A	EYE,ELECTRIC,10-30VDC
3	1	1330018	MOTOR MOUNT WELDMENT	30	1	GG157L050	BELT,GEAR,3/8P,1/2W
4	1	1330019	SUPPORT, UNWINDER	31	1	NNH3/8-16	3/8-16 HEX NUT
5	1	1330022	SUPPORT, UNWINDER	32	1	NNJ10-32	NUT,JAM,THIN #10-32
6	1	1330025	ROD,BENT,CRS,1/2 OD	33	4	NNK5/16-18	KEP NUT, 5/16-18
7	1	1330026	BELT, COVER	34	1	PP12LF050-3/4	PULLEY,GEAR,3/8P,.50B,12T
8	1	1330055	BRACKET, CYLINDER	35	3	SSHC10064	5/16-18 X 1" HEX HEAD
9	1	1335-837A	ROD,1/2 DIA, 180 DEG	36	4	SSHC10080	5/16-18 X 1-1/4 HEX HEAD
10	1	1335189	LINK, IDLER ROLLER	37	1	SSHC25112	3/8-16 X 1-3/4 HEX HEAD
11	1	1335497	ROLLER, FLUTTED, IDLER,	38	2	SSPS90024	#8-32 X 3/8 PAN HD SLOT
12	1	1335498	DRIVE ROLLER, FLUTTED	39	1	SSSC10040	5/16-18 X 5/8 SOC CAP
13	3	1335499	ARM, 1/2" ROD CLAMP	40	2	SSSC70048	#4-40 X 3/4 SOC CAP
14	1	1335738	SHAFT, DRIVE ROLLER	41	2	SSSC90024	#8-32 X 3/8 SOC CAP
15	1	1335M-2046	PLATE,NUT,8-32@.43 CTC	42	6	SSSC98032	#10-32 X 1/2 SOC CAP
16	1	211-057	PULLEY, 3/8P, 12T,1/2B	43	7	SSSC98048	#10-32 X 3/4 SOC CAP
17	1	23080A	BLOCK,CLAMP,EYE	44	2	TTH32425	HANDLE,THRDED,5/16-18X3/4
18	1	23132A	HOLDER, EYE	45	3	TTH34311	HANDLE,THREADED,10-24X3/4
19	1	23218DM	MOTOR ASSY,GEAR	46	2	WWF4	WASHER, FLAT #4
20	1	AAC8DP-3	CYLINDER,AIR,DA	47	9	WWFS10	WASHER, FLAT #10
21	2	AAF1/8	1/8" PLASTIC CLAMP	48	2	WWFS3/8	WASHER, FLAT, 3/8
22	1	AAFBP-8C	BRKT,PIVOT,5/32 BORE	49	14	WWFS5/16	WASHER, FLAT, 5/16
23	1	AAQME-5-10	ELBOW, MALE,5/32X10-32	50	9	WWL10	#10 LW
24	1	BBAW-3Z	BRG,ROD END,F, 10-32	51	1	WWL3/8	3/8 LW
25	2	BBNTA613	BEARING,THRUST,375BORE	52	3	WWL5/16	5/16 LW
26	2	BBS8701-88	BEARING,BALL,.50IDX1.75OD	53	2	WWL8	#8 LW
27	4	BBTRA613	WASHER,THRUST,STL, .375B				

Page 38

From the library of: Diamond Needle Corp

SNUG SCREW, BACK OFF 1/2 TURN, TIGHTEN NUT ON BOTTOM
 3X, PLATE SHOULD SLIDE L-R WITHOUT RATTLING.

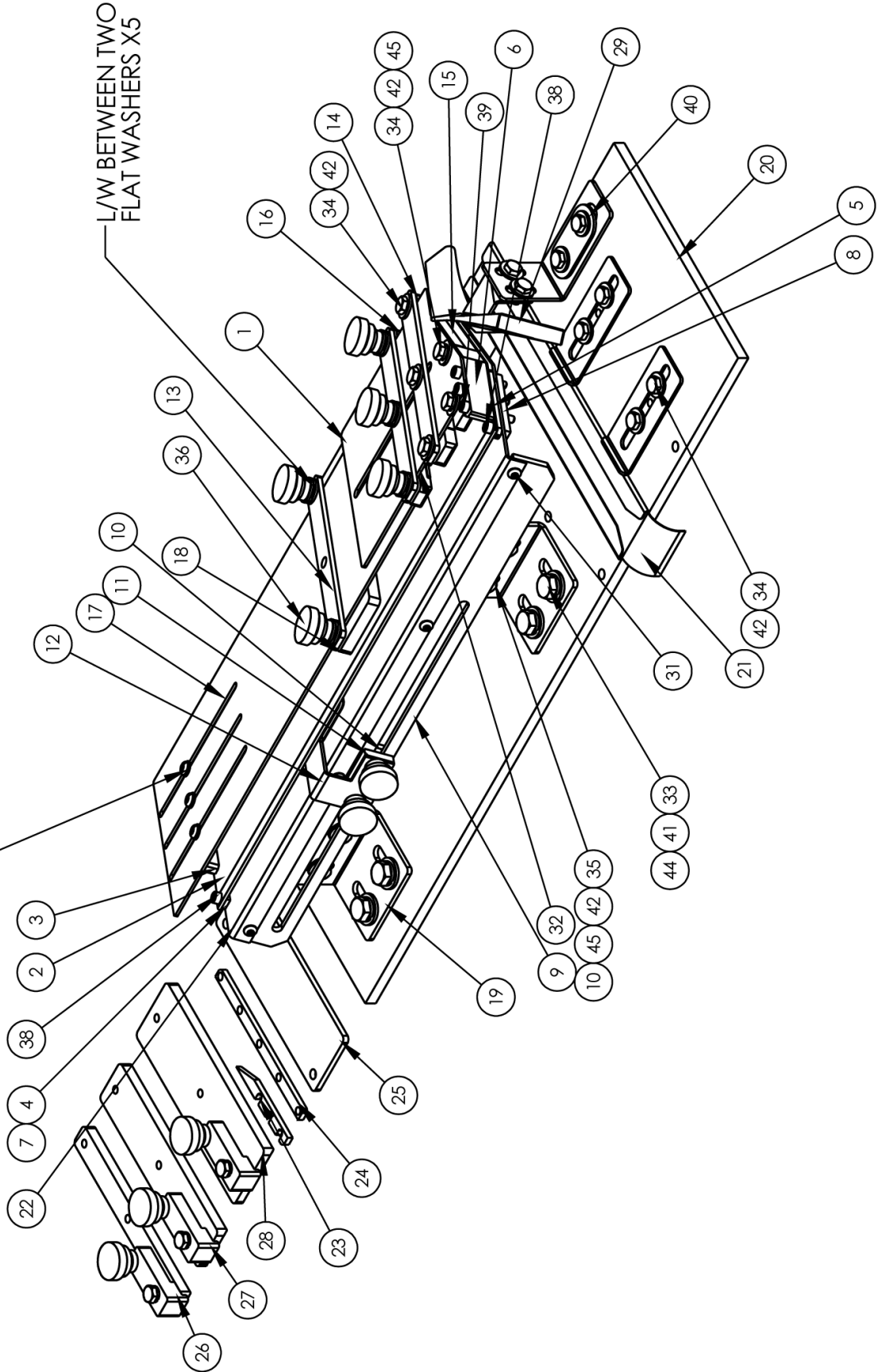

1330110 Folder, 4-12" Adjustable

AAC Drawing Number 1330110 Rev 1

NO.	QTY	PART #	DESCRIPTION
1	1	1330087	FOLDER TOP
2	1	1330088	FOLDER MID PLATE
3	1	1330090	SPACER, 1/4 X 5 HOLE
4	1	1330091	SPACER, .10 X 6 HOLE
5	1	1330092	SPACER, 4 HOLE X .10
6	1	1330093	SPACER, 3 HOLE X .50
7	1	1330094	NUT PLATE, 6 HOLE
8	1	1330095	NUT PLATE, 4 HOLE
9	1	1330096	SLOTTED GUIDE PLATE
10	3	1330097	NUT PLATE,2X10-32X.5
11	1	1330098	WASHER PLATE,2X.196X1
12	1	1330102	EDGE GUIDE, FLANGE
13	3	1330103	WASHER PLATE, 2 X 4.2
14	1	1330105	SPACER, 1/4 X 3/4
15	1	1330106	SPACER PLATE, 1/4, RT
16	1	1330107	NUT PLATE, FOLDER TONGUE
17	1	1330108	FOLDER PLATE LEFT
18	1	1330109	NUT PLATE,1/4X4.2X10-32
19	2	1330112	MOUNT ANGLE
20	1	1330114	BASE PLATE
21	1	1330117	ZIPPER GUIDE ASBLY
22	1	1330118	FOLDER BOTTOM ABLY
23	1	1330133	SPACER, 1/8 X 3 HOLE
24	1	1330134	SPACER , 1/8 X 3 HOLE
25	1	1330140	SPACER, 1/8 X 4.2 X 1-1/2
26	1	1330161	SPACER, FOLDER,1/4X1/2
27	1	1330162	SPACER,FOLDER,1/4X1
28	1	1330163	SPACER, FOLDER, 1/4X1.5
29	1	252-A016084	RAW FINISH BINDER
30	3	NNK6-32	KEP NUT, 6-32
31	4	SSBC80012	BHCS #6-32X..25L
32	4	SSFC80016	6-32 X 1/4 FLAT SOC CAP
33	4	SSHC01032	1/4-20 X 1/2 HHCS
34	11	SSHC98024	10-32 X 3/8 HEX CAP
35	4	SSHC98032	10-32X1/2 HEX HD
36	7	SSMKK3	KNOB,3/4" KNURLED
37	3	SSPS80064	#6-32 X 1 PAN HD SLOTTED
38	2	SSSC80024	6-32 X 3/8 SOC CAP SC
39	3	SSSC80064	6-32 X 1 SOC CAP SC
40	1	WW25DW	PLATE,WASHER
41	4	WWFS1/4	WASHER,FLAT,SAE,1/4
42	25	WWFS10	WASHER, FLAT, #10, SAE
43	3	WWFS6	WASHER, FLAT, #6
44	4	WWL1/4	WASHER,LOCK,1/4
45	11	WWL10	WASHER,LOCK,#10

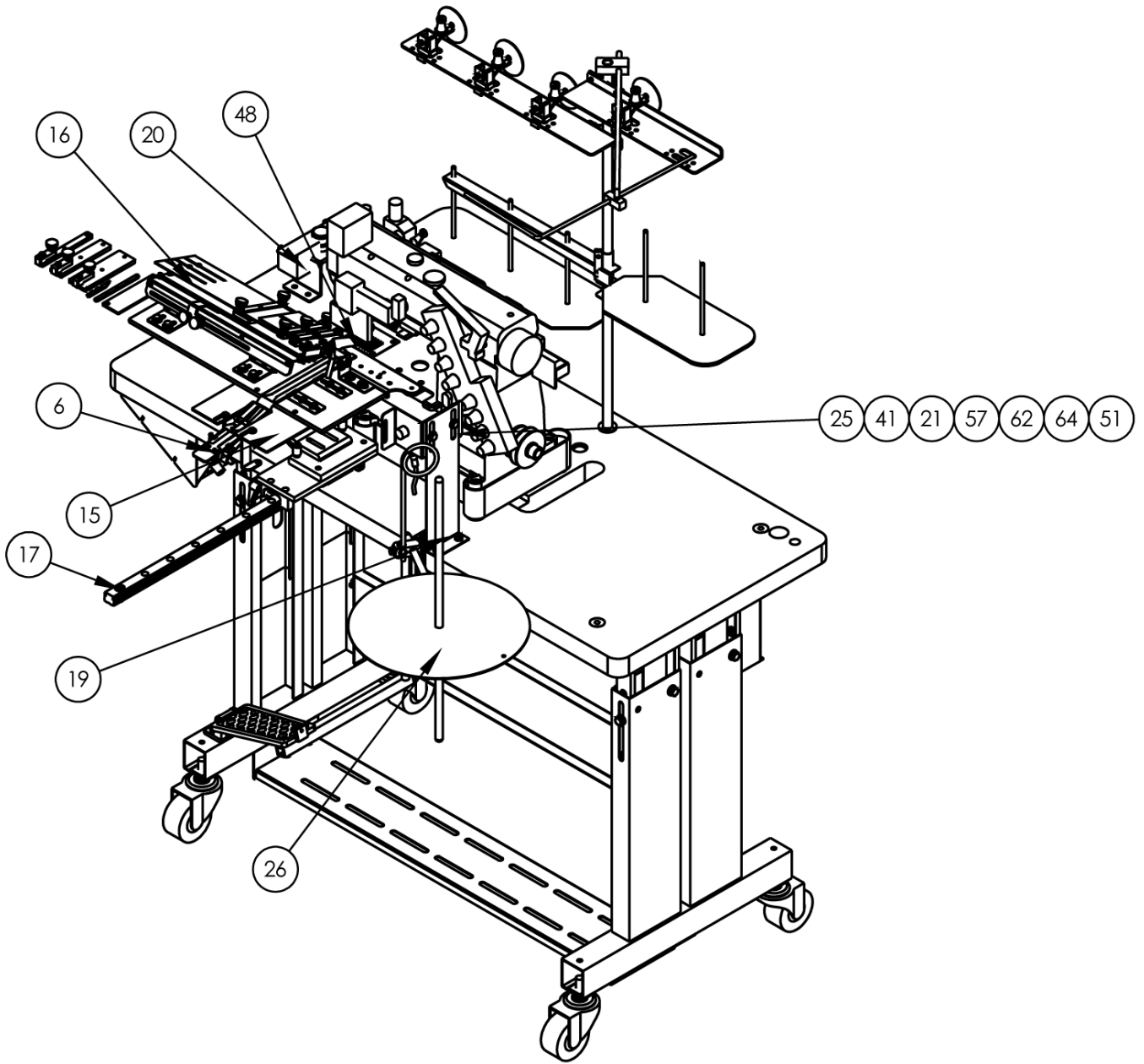

1330120 Motor Table Stand

AAC Drawing Number 1330120 Rev 1

NO.	QTY	PART #	DESCRIPTION	NO.	QTY	PART #	DESCRIPTION	
1	1	4000D-500	CONTROL BOX	35	1	AAV125B	PILOT VALVE	
2	1	97-2602	BRACKET, CLUTCH CYLINDER	36	1	AAVMB33	SWITCH,AIR,3 WAY,W/EXH	
3	1	0411-069B	BRKT, THREAD BREAK DETECT	37	9	FF264-341	TERMBLK,WAGO, TOP, DUAL, GRY	
4	1	0411-069C	BRKT, THREAD BRK DETECTION	38	2	FF264-347	TERMBLK,WAGO, TOP, DUAL, GRN	
5	2	0411-070	CLAMP, SENSOR BRACKET	39	2	FF264-371	TERMBLK,WAGO, TOP, END	
6	1	502-Z088A	ZIPPER BOX, 1-3/8	40	1	FFRK44T-4	CABLE,EYE,12',NO END	
Page 45	7	1330E-WD	DIAGRAM, WIRING	41	1	FFT18FF100Q	EYE, FIXED FIELD, 4IN	
8	1	1959-112	2 POS THREAD PLATE ASSY	42	1	K-4D	HD T LEG ADJ STAND	
9	1	1959-120	BRKT, MOUNTING, 4000D	43	4	K-102-21	ROD, TH, 5/16-18, 2-1/2L	
10	1	1959-161	3 POS THREAD PLATE ASSY.	44	2	K-233	BOX, ELECTRICAL, SQUARE	
11	1	1961-904A	MOUNT, REGULATORS	45	2	K-234	COVER, 4IN SQUARE	
Page 40	12	4	4003-IS3WT2	SENSOR, THREAD BREAK	46	6	K-235	CONNECTOR, ROMEX, 1/2"
13	1	4058-2	MOTOR, 3/4HP, 110/220V, 1PH	47	1	K-29402	CAST IRON FOOT PEDAL	
14	1	11200	BUMPER, 1/4-28	48	1	M1V67-018	FOOT, 2N, ZIPPER	
15	1	1330015	PLATE, 1-3/8" Z-BOX MOUNT	49	4	NNH5/16-18	5/16-18 HEX NUT	
Page 23	16	1	1330110	FOLDER, 4-12" ADJ	50	1	NNJ1/4-28	NUT, HEX, JAM, 1/4-28
Page 29	17	1	1330119	ASSY, FOLDER MOUNT	51	4	NNK1/4-20	NUT, HEX, KEP, 1/4-20, W/LOCK
18	1	1330147	TREADLE EXTENSION TUBE	52	2	NNK8-32	NUT, KEP, 8-32	
19	1	1330148	SLACK EYE TARGET	53	4	NNK10-32	KEP NUT, 10-32	
20	1	1330164	PAUSE BUTTON BOX ASSY	54	4	NNM103	NUT, RECESSED, 5/16-18	
21	1	1330165	BRACKET, MATERIAL OUT	55	1	SSBE90064	EYEBOLT, 8-32X1	
22	1	1330222	TABLE, TOP	56	2	SSFS01048	1/4-20 X 3/4 FHS	
23	2	1330225	BRKT, WAGO BLOCK	57	4	SSHCO1032	1/4-20 X 1/2 HHCS	
24	1	1330229	SEW HEAD ASSY W/ROLLERS	58	2	SSHCO1056	1/4-20 X 7/8 HEX CAP	
25	1	1347036	SENSOR BRACKET	59	2	SSHCO98032	10-32X1/2 HEX HD	
Page 33	26	1	1347630	BINDING REEL ASBLY	60	2	SSPS98080	10-32X1-1/4 PAN HD SLOT
27	1	AA198-5102	REGULATOR W/GAUGE & NUT	61	2	SSZH#10064	SCREW, SHT. METAL HEX 10	
28	1	AA198-RP3	REGULATOR, PRECISION AIR	62	8	WWFS1/4	WASHER, FLAT, SAE, 1/4	
29	1	AA198RR508	FLOW CONTROL, 5/32 X 1/8"	63	8	WWFS5/16	WASHER, FLAT, 5/16	
30	1	AAC7DP-2	CYLINDER, AIR, DA	64	10	WWFS10	WASHER, FLAT, #10, SAE	
31	1	AAF122A-A	1/8" NPT HEX CLOSE	65	4	WWL1/4	WASHER, LOCK, 1/4	
32	1	AAF23224X2	BUSHING, BRASS	66	8	WWL5/16	5/16 LW	
33	1	AAQMC-4-4	QUICK MALE CONN 1/4 X 1/4	67	4	SSSC98032	#10-32 X 1/2 SOC CAP	
34	4	AAQME-5-8	QUICK MALE ELBOW					

From the library of: Diamond Needle Corp

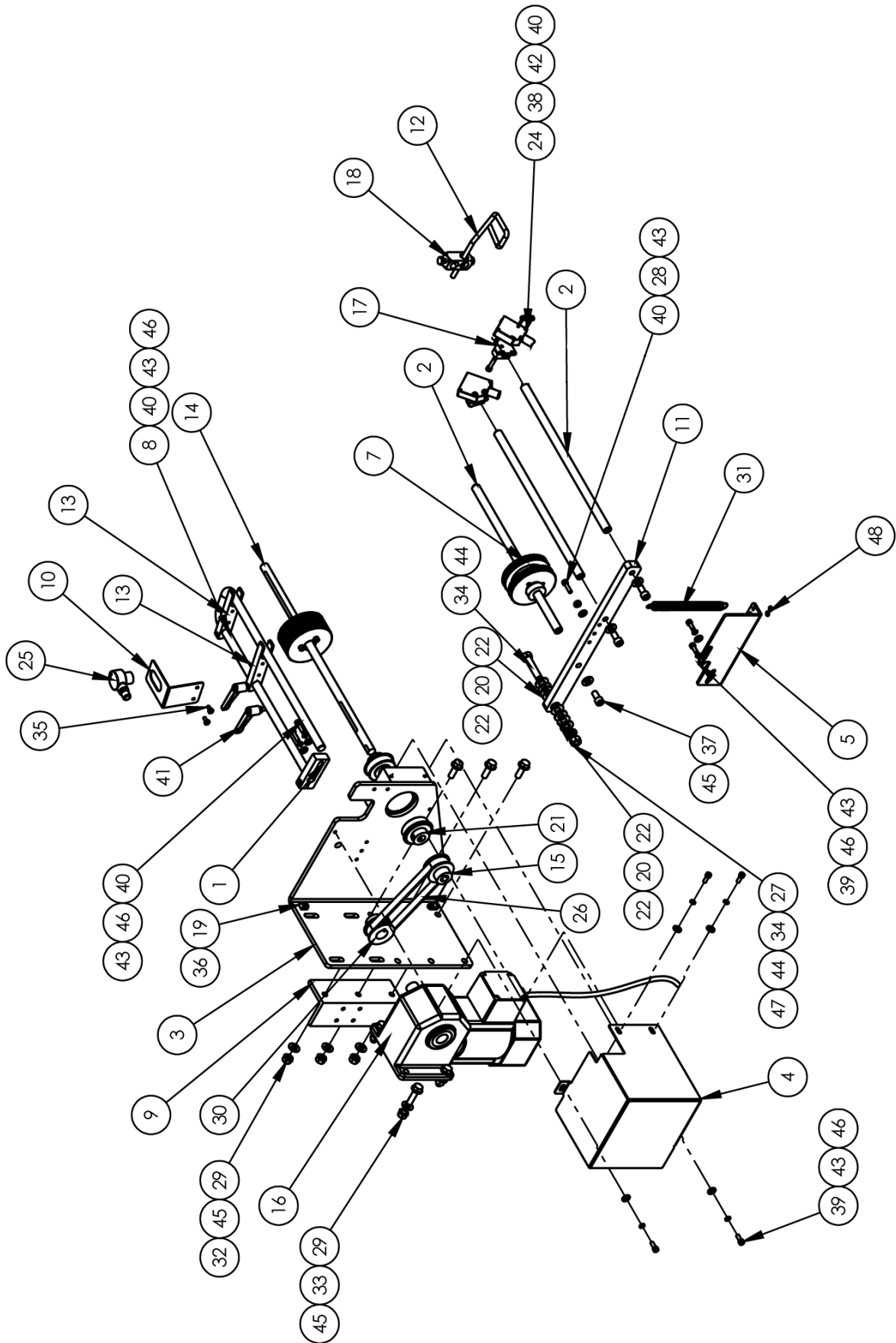

1330113 Zipper Unwind W/ Pulls

AAC Drawing Number 1330113 Rev 2

Page

NO.	QTY	PART #	DESCRIPTION
1	1	1325-346	HOLDER,ROD,1/2 D,SLOT MNT
2	3	1330017	SHAFT, IDLER ROLLER
3	1	1330018	MOTOR MOUNT WELDMNT
4	1	1330026	BELT, COVER
5	1	1330055	BRACKET, CYLINDER
6	1	1330127	ROLLER,ZIPPER,DRIVE
7	1	1330128	ROLLER,ZIPPER,IDLER
8	1	1330129	ROD,1/2 DIA, 180 DEG
9	1	1330131	MOUNT, ANGLE,FEEDER
10	1	1330132	BRACKET, SEN, RT ANGLE
11	1	1330157	ARM, TENSION
12	1	1330175	ROD,GUIDE,ZIPPER FEED
13	2	1335499	ARM, 1/2" ROD CLAMP
14	1	1335738	SHAFT, DRIVE ROLLER
15	1	211-057	PULLEY, 3/8P, 12T,1/2B
16	1	23218DM	MOTOR ASSY,GEAR
17	2	265155A	HOLDER, EYE, 1/2 BORE
18	1	A-U	ROD CROSS BLOCK
19	2	AAF1/8	1/8" PLASTIC CLAMP
20	2	BBNTA613	BEARING, THRUST,375BORE
21	2	BBS8701-88	BEARING,BALL,.50IDX1.75OD
22	4	BBTRA613	WASHER,THRUST,STL, .375B
23	2	CCCL8F	CLAMP COLLAR- 1/2
24	2	FFQM42VN6A	EYE,ELECTRIC,10-30VDC
25	1	FFT18FF100Q	EYE,FIXED FIELD, 4IN
26	1	GG157L050	BELT,GEAR,3/8P,1/2W
27	1	NNH3/8-16	3/8-16 HEX NUT
28	1	NNK10-32	KEP NUT, 10-32
29	7	NNK5/16-18	NUT,KEP,5/16-18
30	1	PP12LF050-3/4	PULLEY,GEAR,3/8P,.50B,12T
31	1	RRLE045E12	Lee Spring LE-031 D8
32	3	SSHC10064	5/16-18 X 1 HHCS
33	4	SSHC10080	5/16-18 X 1-1/4 HEX HEAD
34	1	SSHC25112	3/8-16 X 1-3/4 HEX HEAD
35	2	SSPP90024	8-32X3/8 PAN PHLPS
36	2	SSPS90024	#8-32 X 3/8 PAN HD SLOT
37	3	SSSC10040	5/16-18 X 5/8 SOC CAP
38	4	SSSC70048	#4-40 X 3/4 SOC CAP
39	6	SSSC98032	#10-32 X 1/2 SOC CAP
40	5	SSSC98048	#10-32 X 3/4 SOC CAP
41	2	TTH34311	HANDLE,THREADED,10-24X3/4
42	4	WWF4	WASHER, FLAT #4
43	9	WWFS10	WASHER, FLAT #10
44	2	WWFS3/8	WASHER, FLAT, 3/8
45	17	WWFS5/16	WASHER, FLAT, 5/16
46	8	WWL10	#10 LW
47	1	WWL3/8	3/8 LW
48	4	WWL8	WASHER,LOCK,#8

Page 41

Page 43

Page 25

Page 15

Page 38

From the library of: Diamond Needle Corp

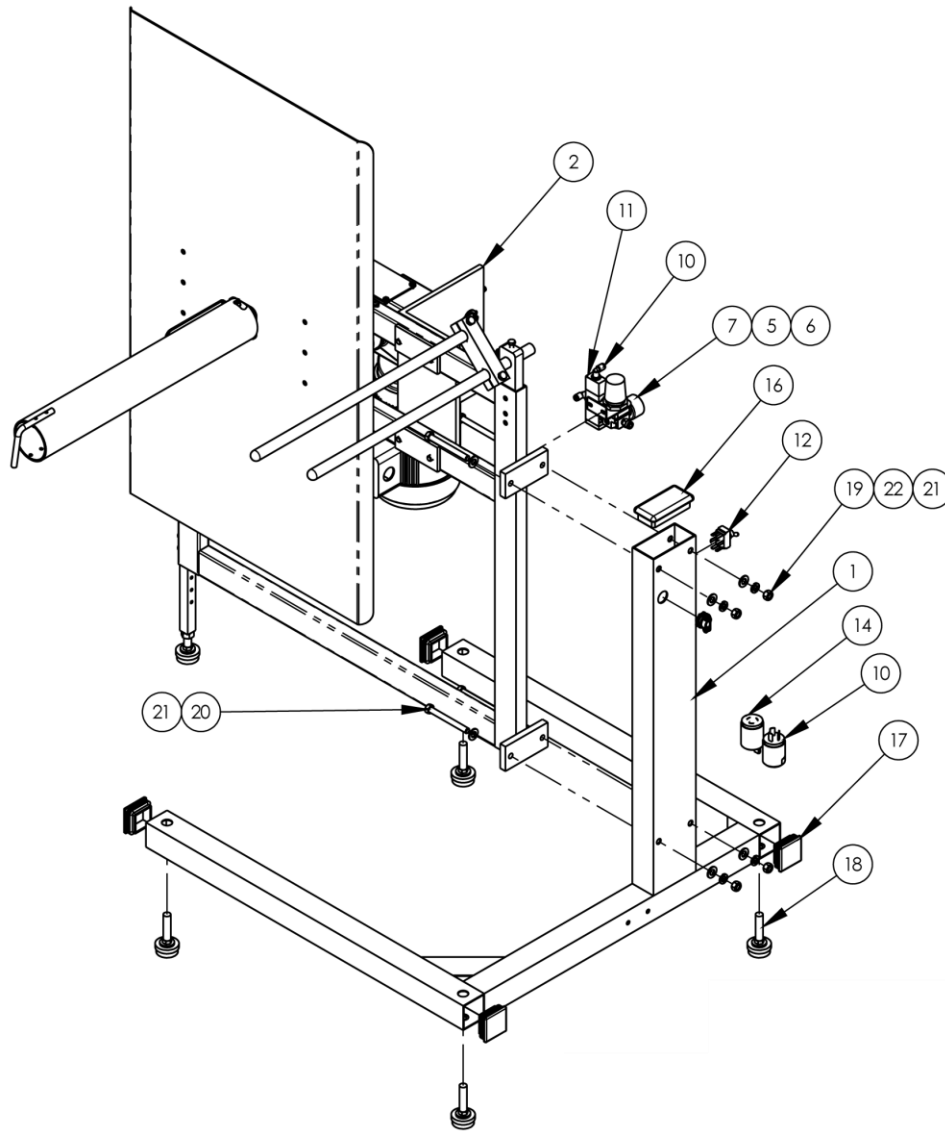

From the library of: Diamond Needle Corp

1330200 Rewinder W/mounting Assembly

AAC Drawing Number 1330200 Rev 4

NO.	QTY	PART #	DESCRIPTION	NO.	QTY	PART #	DESCRIPTION
1	1	1330201	REWINDER MOUNTING	12	1	FF23F356	DPDT SWITCH,ON-OFF-ON
2	1	1347098	REWIND ASSY W/SLEEVE	10	1	FFHBL4570C	PLUG, 2P/3W, GROUNDING
3	AR	1347MA-PD	PNEUMATIC DIAGRAM	14	1	FFHBL4579C	RECEPTACLE,3 POLE,3W
4	AR	1347MA-WD	WIRING DIAGRAM	15	2	K-235	CONNECTOR,ROMEX,1/2"
5	1	4130-001	REGULATOR BRACKET	16	1	MM132-2X4	END CAP,RECT,BLACK
6	1	AA198-502	REGULATOR,AIR,0-30 PSI	17	4	MM9565K56	PLUG,BLACK, 2" SQ
7	1	AA198-5032	0-60PSI AIR GAGE 1/8NPT	18	4	MMFB4444	FOOT, RUBBER
8	1	AAF122A-A	1/8" NPT HEX CLOSE	19	4	NNH3/8-16	3/8-16 HEX NUT
9	1	AAQMC-4-8	QUICK MALE CONN,1/4X1/8	20	4	SSHHC25224	3/8-16 X 3-1/2 HEX HEAD
10	2	AAQME-5-4	ELBOW, MALE 5/32X1/4NPT	21	8	WWFS3/8	WASHER, FLAT, 3/8
11	1	AAV125B	PILOT VALVE	22	4	WWL3/8	3/8 LW

Page 31

Page 42

Page 44

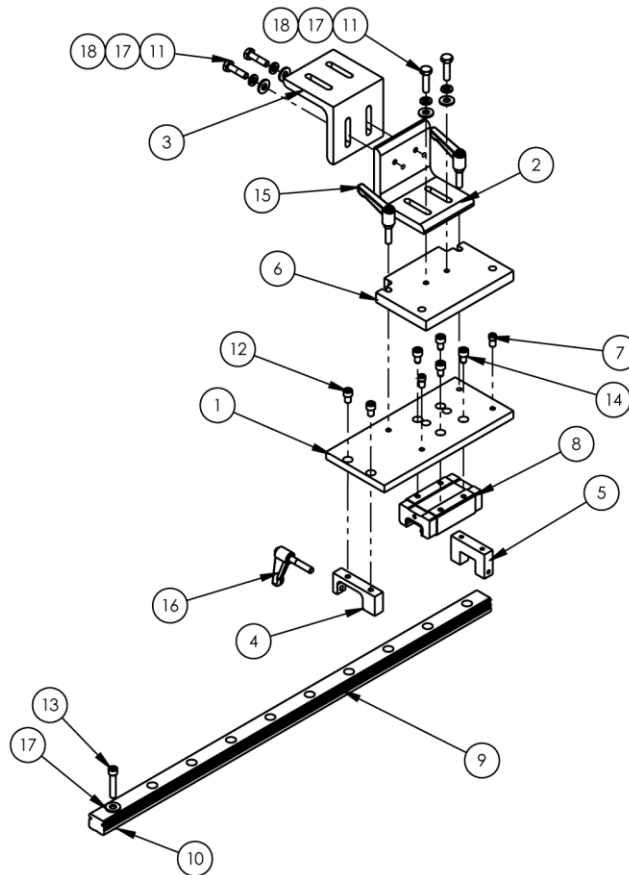

1330119 Folder Mount Assembly

AAC Drawing Number 1330119 Rev 1

NO.	QTY	PART #	DESCRIPTION
1	1	1330104	ADAPTOR, FOLDER
2	1	1330124	MOUNT, FOLDER
3	1	1330125	MOUNT, FOLDER, UPPER
4	1	1334-1006	MOUNT, LOCKING HANDLE
5	1	1335-310	STOP BLOCK, FRONT
6	1	1347062	BASE, FOLDER MOUNT
7	2	1347088	STUD, .312 OD, 1/4-20
8	1	MMAGH25CAN	LINEAR BEARING
9	1	MMAGR25590N	RAIL, LINEAR AG SERIES
10	1	NNK1/4-20	NUT, HEX, KEP, 1/4-20, W/LOCK
11	4	SSHC01064	1/4-20 X 1 HHCS
12	2	SSSC01024	1/4-20 X 3/8 SOC CAP SC
13	1	SSSC01080	1/4-20X1-1/4, SOC CAP
14	4	SSSCM6X10	M6X10 SOC CAP SCREW
15	2	TTH32415	HANDLE, THREADED, 1/4-20X7/8
16	1	TTH32416	HANDLE, THRD, 1/4-20X1-1/8
17	5	WWFS1/4	WASHER, FLAT, SAE, 1/4
18	4	WWL1/4	WASHER, LOCK, 1/4

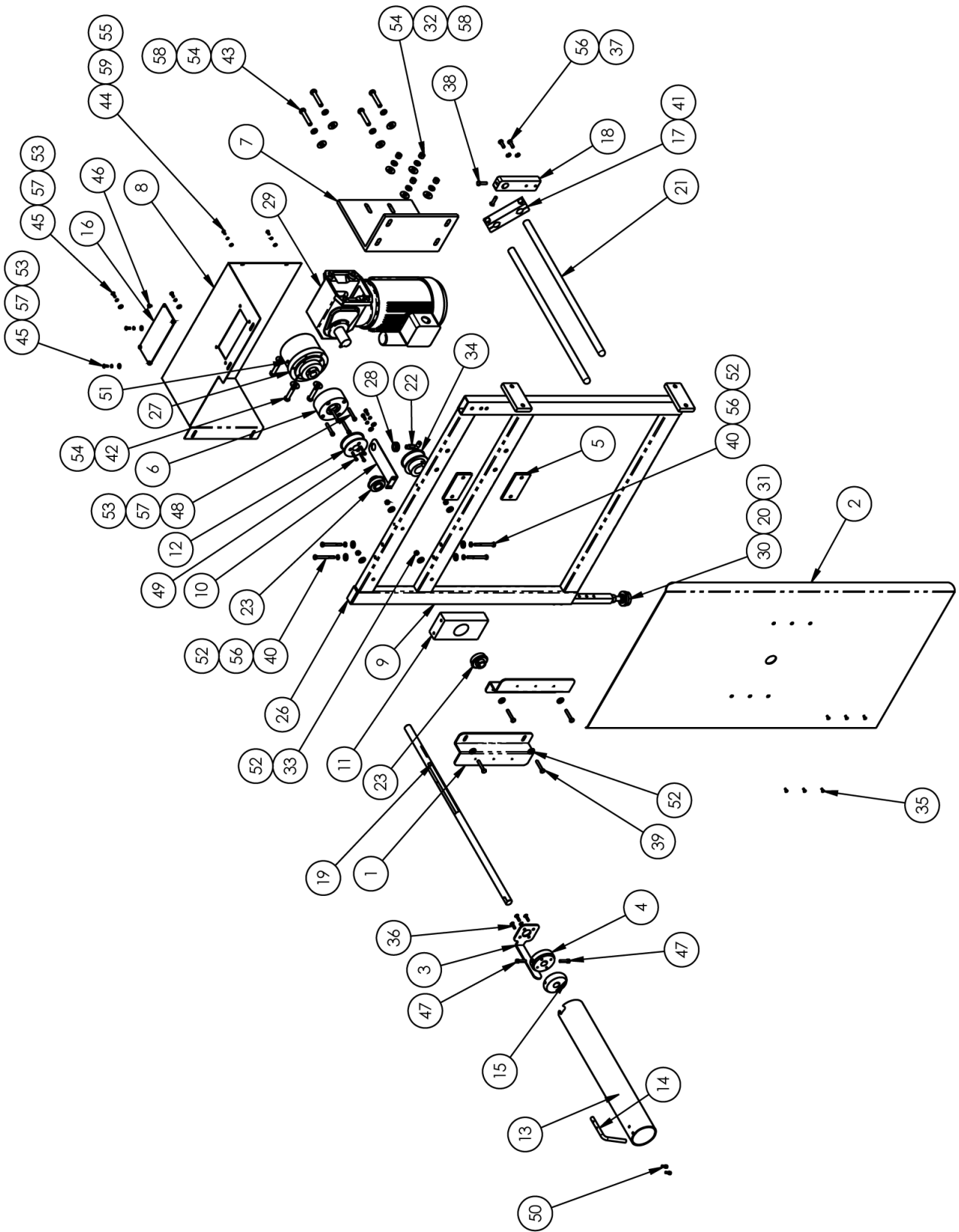

From the library of: Diamond Needle Corp

1347098 Rewind Assembly w/Sleeve

AAC Drawing Number 1347098 Rev 1

NO.	QTY	PART #	DESCRIPTION	NO.	QTY	PART #	DESCRIPTION
1	2	1334326	MOUNT, FLANGE	31	1	NNH1/2-13	NUT,HEX,1/2-13
2	1	1334376	PLATE, REWIND,24 X 40	32	4	NNH3/8-16	NUT,HEX,3/8-16
3	1	1334387	CATCH, MATL. TAKEUP REEL	33	4	NNK1/4-20	KEP NUT, 1/4-20
4	1	1334388	HUB, TAKEUP SPINDLE	34	1	PP22LB075-1-1/8	PULLEY, GEAR, 3/8P, 22T
5	2	1961-319	PLATE,NUT,3/8-16@3.00 CTC	35	6	SSFC80024	6-32 X 3/8 FLAT CAP
6	1	1961-321	PLATE, ADAPTOR, AIR CLUTC	36	4	SSFC98048	#10-32 X .75 SHCSF
7	1	1961-331	MOUNT, MOTOR	37	4	SSHC01048	1/4-20 X 3/4 HEX CAP
8	1	1961-332	COVER, MOTOR	38	2	SSHC01064	1/4-20 X 1 HHCS
9	1	1961-335	FRAME, PREFEED & REWIND A	39	4	SSHC01096	1/4-20 X 1-1/2 HHCS
10	1	1961-354B	SUPPORT, AIR CLUTCH	40	4	SSHC01160	1/4-20 X 2-1/2 HHCS
11	1	1961-365B	BLOCK, BEARING MOUNT	41	2	SSHC10096	5/16-18 X 1-1/2 HHCS
12	1	1961-366A	PULLEY,CLUTCH,22 TH,3/8 P	42	4	SSHC25096	3/8-16 X 1 1/2 HEX HEAD
13	1	1961-372	SLEEVE, REWIND, 18" CAP	43	4	SSHC25128	3/8-16 X 2 HEX CAP
14	1	1961-374A	HANDLE, SLEEVE	44	4	SSPP98032	10-32 X 1/2 PAN PHIL
15	1	1961-379	SUPPORT,REWIND SLEEVE	45	4	SSPS95016	#10-24 X 1/4 PAN HD SLTD
16	1	1961104	COVER, INSPECTION	46	2	SSSC01064	1/4-20 X 1 SOC CAP
17	1	1962-3201	CLAMP, 3/4 ROD, 3" CTC	47	4	SSSC01096	1/4-20 X 1-1/2 SOC CAP
18	1	1962-3202A	SUPPORT, TENSION PULLER	48	3	SSSC90064	#8-32 X 1 SOC CAP SC
19	1	1962-375	SHAFT, AIR CLUTCH, MM8028	49	4	SSSC98032	10-32X1/2, SOC CAP
20	1	26127	LEG FOR AP-26-02	50	2	SSSS01016	1/4-20 X 1/4 KNURL PT
21	2	33008202	ROD,ROLL,SST,3/4X21 W/RAD	51	14	WWF1/4	WASHER, FLAT, 1/4", COM
22	1	AAQMEL-5-8	QUICK MALE ELBOW, LONG	52	6	WWF10	WASHER, FLAT, #10, COM
23	2	BBS8703-88	BEARING,BALL,.75IDX1.75OD	53	2	WWF8	WASHER, FLAT, #8
24	1	GG225L075	GEAR BELT	54	8	WWL1/4	WASHER,LOCK,1/4
25	1	K-235A	ROMEX CONNECTOR	55	6	WWL10	WASHER,LOCK,#10,S/S
26	1	MM132-1496	PLUG 1 X 2	56	8	WWL3/8	WASHER, LOCK, 3/8
27	1	MM802860	CLUTCH,AIR,3/4 BORE,4.5"D	57	2	WWL8	WASHER,LOCK,#8
28	1	MM9600K21	GROMMET,RUBBER,9/16 ID	58	2	SSPP90024	8-32X3/8 PAN PHLPS
29	1	MMBH2LM22R	MOTOR,GEAR,R/A,220V	59	12	WWF3/8	WASHER,FLAT,3/8 OR 10MM
30	1	MMFB4444	FOOT, RUBBER				

From the library of: Diamond Needle Corp

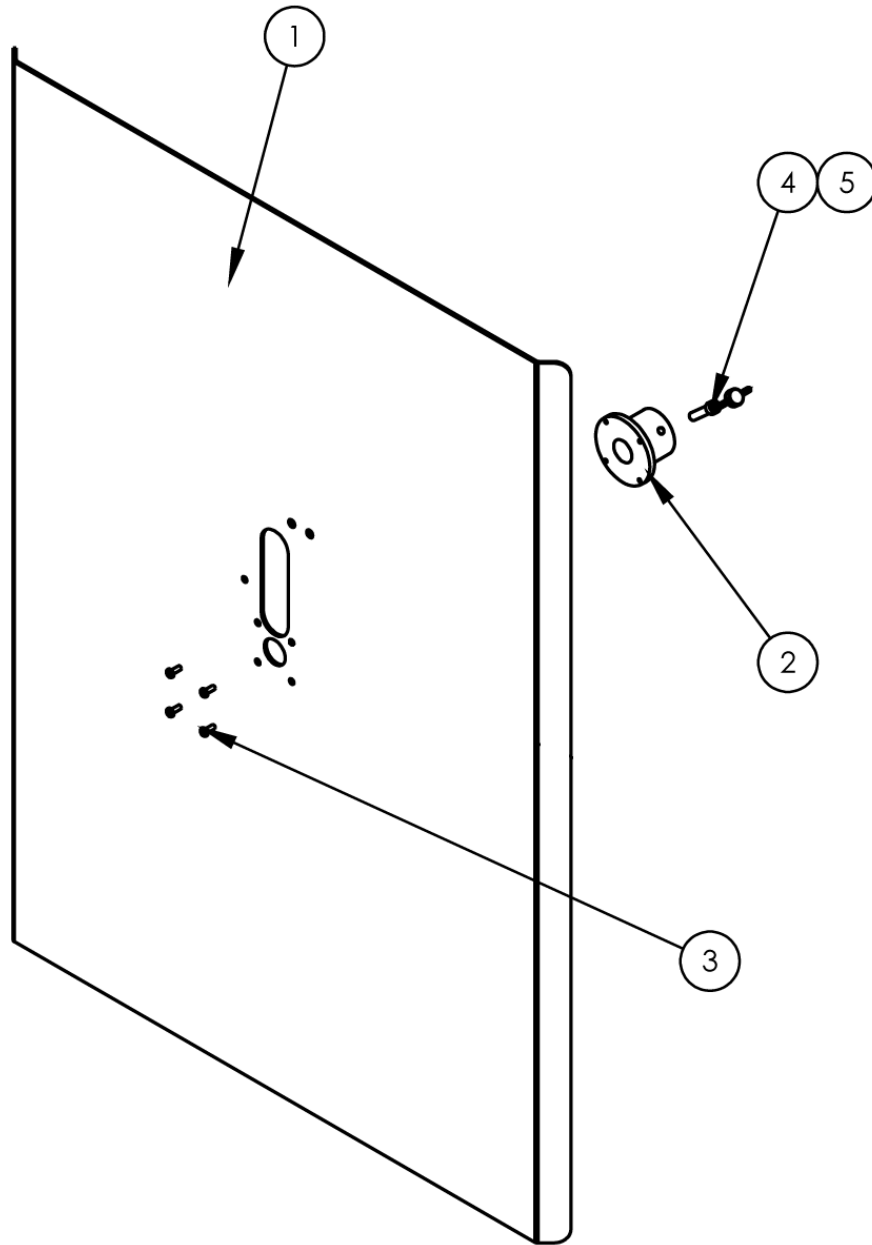

From the library of: Diamond Needle Corp

785-A97-36 Stationary Disc Assembly, 36"

AAC Drawing Number 9004421 Rev 0

NO.	QTY	PART #	DESCRIPTION
1	1	784B-2436	PLATE, ALU, 23.75 X 31.75
2	1	A-9-048B	HUB, H/DUTY, 3/4 SHAFT
3	4	SSPS80024	#6-32 X 3/8 LG PAN HD
4	1	SSSC01064	1/4-20 X 1 SOC CAP
5	1	SSW#1_4	WING SCREW KNOB

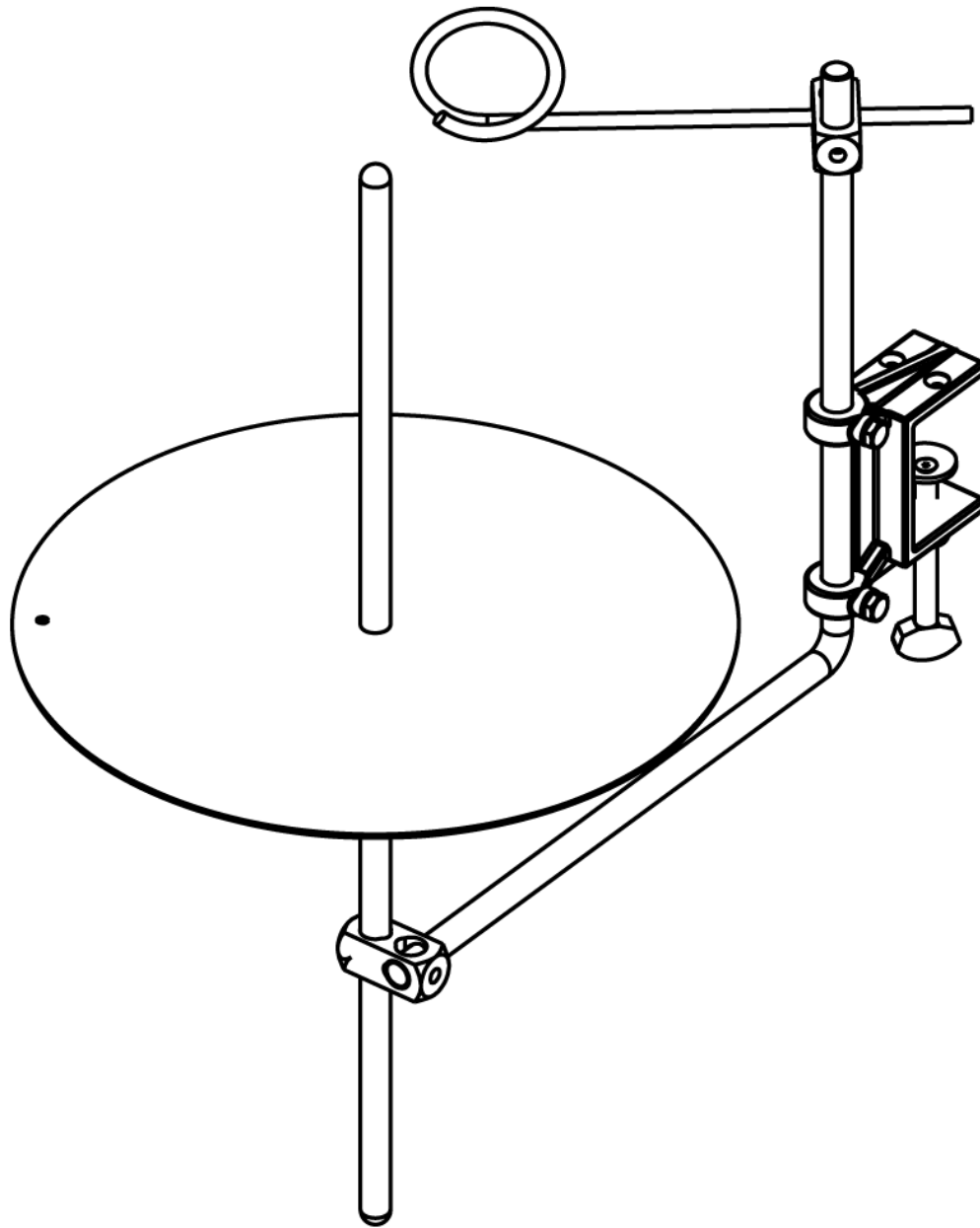

From the library of: Diamond Needle Corp

1347630 Binding Reel Assembly

AAC Drawing Number 1347630 Rev 0

NO.	QTY	PART #	DESCRIPTION
1	1	1347116	RING, TAPE GUIDE
2	1	780-102C	ROD, BENT, 90 DEG
3	1	781-3-S1401	PIPING STAND, 12" DISC
4	1	A-7-1/2	TABLE CLAMP ASSEMBLY
5	2	A-U	ROD CROSS BLOCK

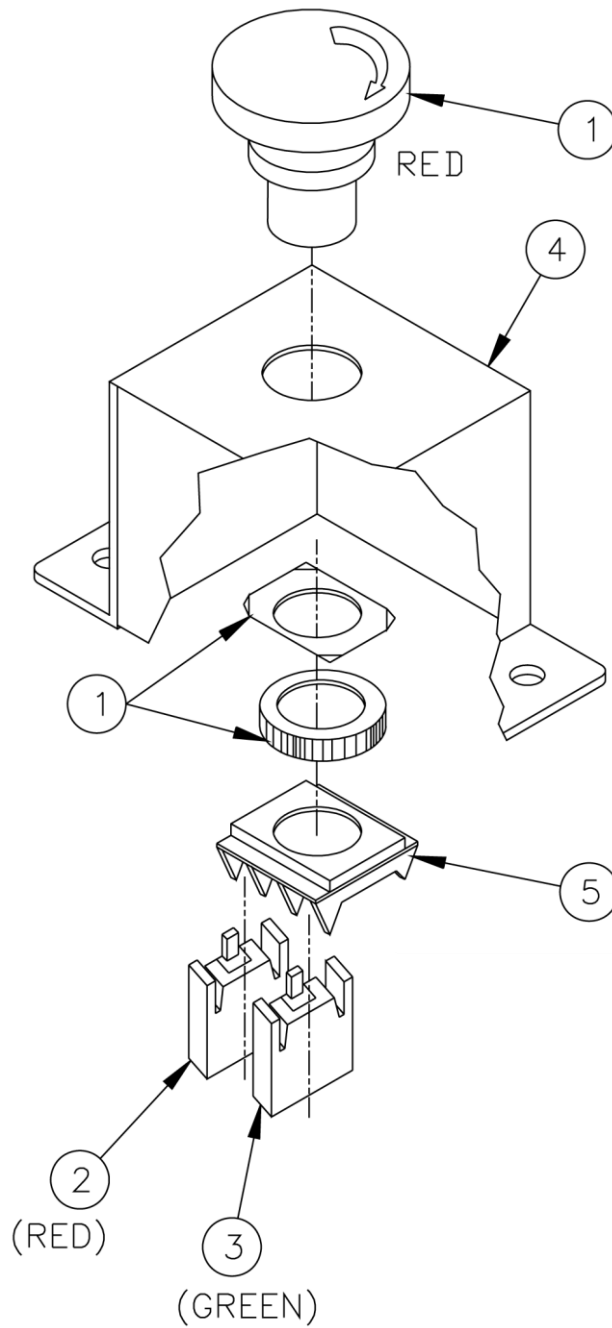

From the library of: Diamond Needle Corp

213-005 Table Mount Button Assembly

AAC Drawing Number 290645A Rev 3

NO.	QTY	PART #	DESCRIPTION
1	1	EPMTS44	Push Button
2	1	EE3X01	Switch, N.C. SPST
3	1	EE3X10	Switch, N.O. SPST
4	1	350-12154	Bracket
5	1	EEA3L	Mounting Latch

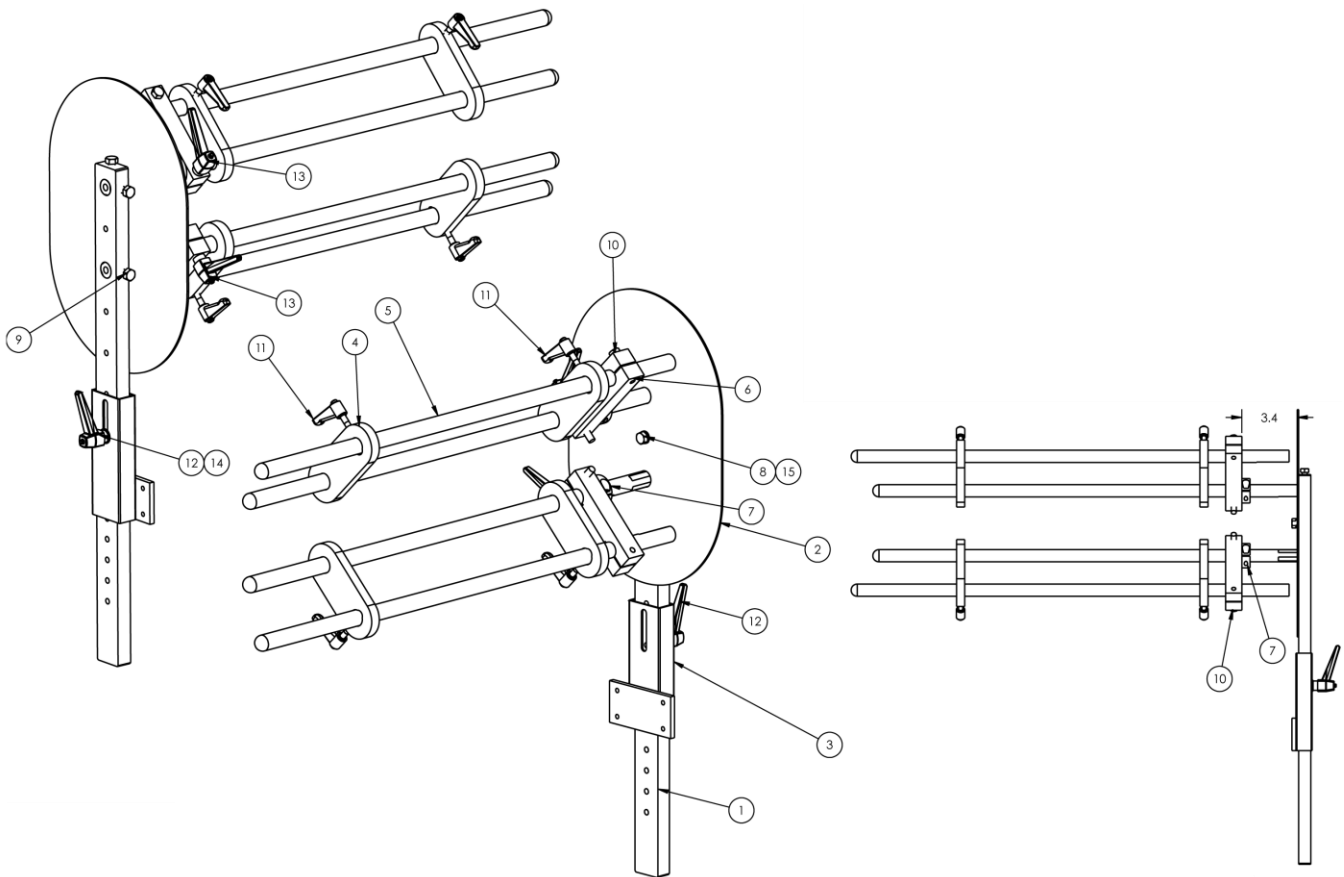

1330160 Dual Tension Rack

AAC Drawing Number 1330160 Rev 0

NO.	QTY	PART #	DESCRIPTION
1	1	1330138	SUPPORT, TENSIONER, DUAL
2	1	1330159	DISC, SCALE MOUNT
3	1	1347093	SUPPORT, TENSIONER
4	4	1961-211	PLATE, EDGE GUIDE
5	4	1961-252D	ROD, ROLL, 27" L
6	2	1962-3201	CLAMP, 3/4 ROD, 3" CTC
7	2	CCCL12F	CLAMP COLLAR- 3/4
8	1	SSHC10032	5/16-18 X 1/2 HHCS
9	4	SSHC10048	5/16-18 X 3/4 HHCS
10	2	SSHC10096	5/16-18 X 1-1/2 HHCS
11	4	TTH32416	HANDLE, THRD, 1/4-20X1-1/8
12	1	TTH32425	HANDLE, THRDED, 5/16-18X3/4
13	2	TTH32429	HANDLE, THRD, 5/16-18X2.0
14	1	WWFS5/16	WASHER, FLAT, SAE, 5/16
15	1	WWL5/16	WASHER, LOCK, 5/16

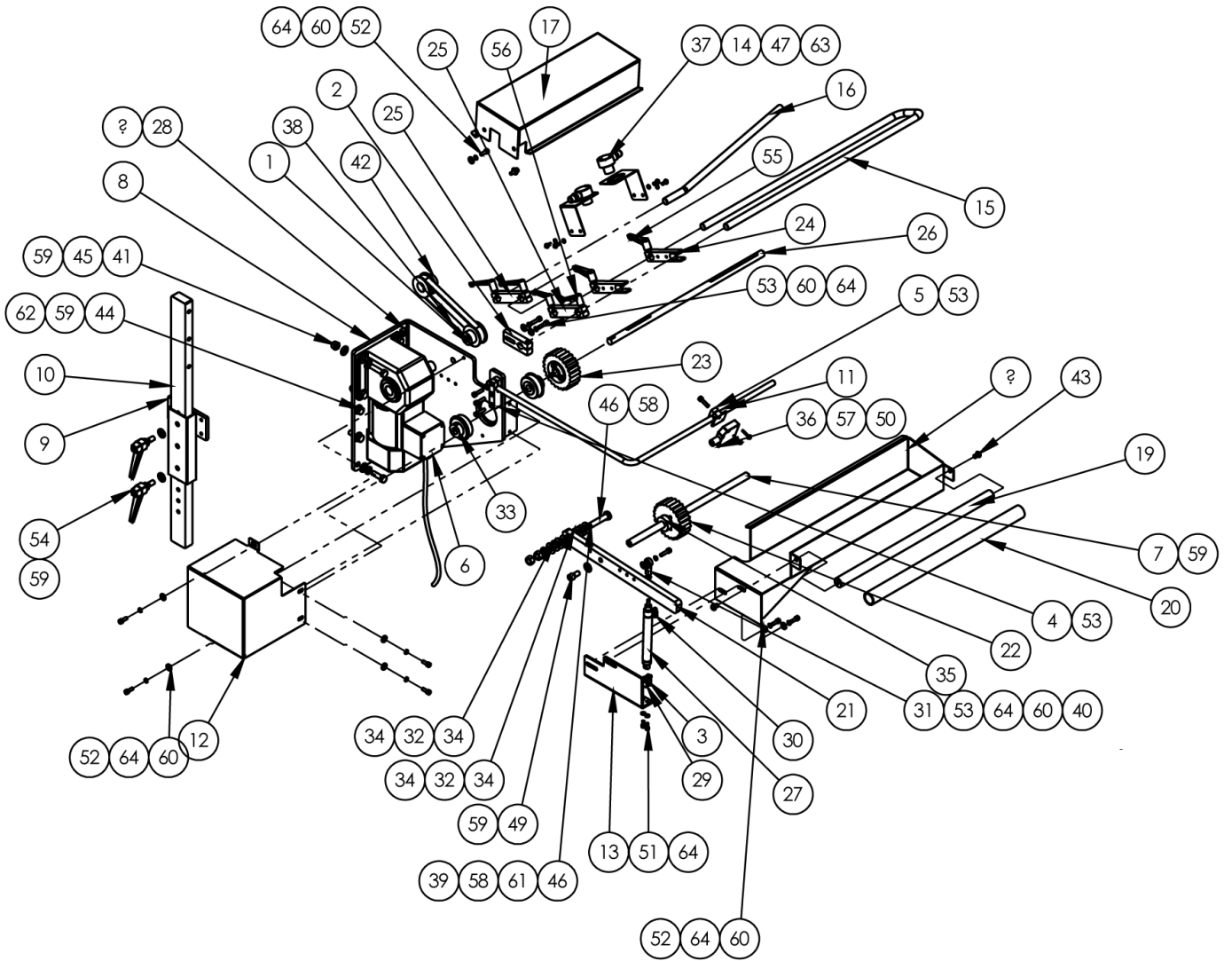

From the library of: Diamond Needle Corp

1330176 Unwinder Motor Assembly

AAC Drawing Number 1330176 Rev 1

NO.	QTY	PART #	DESCRIPTION	NO.	QTY	PART #	DESCRIPTION
1	1	211-057	PULLEY, 3/8P, 12T, 1/2B	33	2	BBS8701-88	BEARING, BALL, .50IDX1.75OD
2	1	1325-346	HOLDER, ROD, 1/2 D, SLOT MNT	34	4	BBTRA613	WASHER, THRUST, STL, .375B
3	1	1335M-2046	PLATE, NUT, 8-32@.43 CTC	35	2	CCCL8F	CLAMP COLLAR- 1/2
4	1	23080A	BLOCK, CLAMP, EYE	36	1	FFQM42VN6A	EYE, ELECTRIC, 10-30VDC
5	1	23132A	HOLDER, EYE	37	2	FFT18FF100Q	EYE, FIXED FIELD, 4IN
6	1	23218DM	MOTOR ASSY, GEAR	38	1	GG157L050	BELT, GEAR, 3/8P, 1/2W
7	1	1330017	SHAFT, IDLER ROLLER	39	2	NNH3/8-16	NUT, HEX, 3/8-16
8	1	1330018	MOTOR MOUNT WELDMENT	40	1	NNJ10-32	NUT, JAM, THIN #10-32
9	1	1330019	SUPPORT, UNWINDER	41	4	NNK5/16-18	NUT, KEP, 5/16-18
10	1	1330022	SUPPORT, UNWINDER	42	1	PP12LF050-3/4	PULLEY, GEAR, 3/8P, .50B, 12T
11	1	1330025	ROD, BENT, CRS, 1/2 OD	43	2	SSBC01024	1/4-20 X 3/8 BUT CAP SC
12	1	1330026	BELT, COVER	44	3	SSHHC10064	5/16-18 X 1 HHCS
13	1	1330055	BRACKET, CYLINDER	45	4	SSHHC10080	5/16-18 X 1-1/4 HHCS
14	2	1330132	BRACKET, SEN, RT ANGLE	46	1	SSHHC25112	3/8-16 X 1-3/4 HEX HEAD
15	1	1330158	ROD, 1/2 DIA, 180 DEG	47	4	SSPP90024	8-32X3/8 PAN PHLPS
16	1	1330174	ROD, GUIDE, BORDER ROLL	48	2	SSPS98024	10-32X3/8 PAN HD SLOT
17	1	1330234	COVER, UNWINDER, UPPER	49	1	SSSC10040	5/16-18X5/8 SOCKET CAP
18	1	1330236	COVER, UNWINDER, LOWER	50	2	SSSC70048	4-40 X 3/4 SOCKET CAP
19	1	1330237	ROD, SST, TAPPED 10-32, 3/4D	51	2	SSSC90024	#8-32 X 3/8 SOC CAP SC
20	1	1330238	ROLLER, PVC, 3/4" SCH 40	52	8	SSSC98032	10-32X1/2, SOC CAP
21	1	1335189	LINK, IDLER ROLLER	53	7	SSSC98048	10-32 X 3/4 SOC CAP
22	1	1335497	ROLLER, FLUTTED, IDLER,	54	2	TTH32425	HANDLE, THRDED, 5/16-18X3/4
23	1	1335498	DRIVE ROLLER, FLUTTED	55	2	TTH34311	HANDLE, THREADED, 10-24X3/4
24	2	1335499	ARM, 1/2" ROD CLAMP	56	4	TTH48070	HANDLE, THREADED 10-32X.63
25	2	1335501	ARM, 1/2" ROD CLAMP	57	2	WWF4	WASHER, FLAT, #4
26	1	1335738	SHAFT, DRIVE ROLLER	58	2	WWFS3/8	WASHER, FLAT, SAE, 3/8
27	1	AAC8DP-3	CYLINDER, AIR, DA	59	14	WWFS5/16	WASHER, FLAT, SAE, 5/16
28	2	AAF1/8	1/8" PLASTIC CLAMP	60	11	WWFS10	WASHER, FLAT, #10, SAE
29	1	AAFBP-8C	BRKT, PIVOT, 5/32 BORE	61	1	WWL3/8	WASHER, LOCK, 3/8
30	1	AAQME-5-10	ELBOW, MALE, 5/32X10-32	62	3	WWL5/16	WASHER, LOCK, 5/16
31	1	BBAW-3Z	BRG, ROD END, F, 10-32	63	4	WWL8	WASHER, LOCK, #8
32	2	BBNTA613	BEARING, THRUST, 375BORE	64	13	WWL10	WASHER, LOCK, #10

From the library of: Diamond Needle Corp

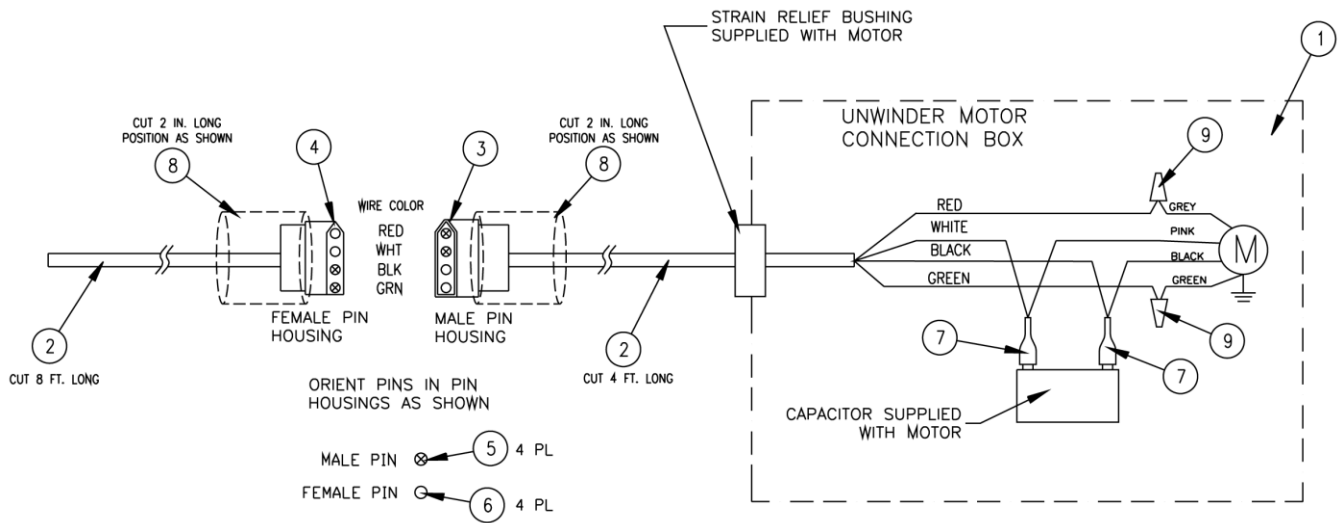

From the library of: Diamond Needle Corp

23218DM Gear Motor Assembly

AAC Drawing Number 192513A Rev 0

NO.	QTY	PART #	DESCRIPTION
1	1	23218D	GEAR MOTOR
2	12'	EE18-4	SJO CABLE
3	1	FF274-224	4 PIN MALE CONN.
4	1	FF274-234	4 PIN FEMALE CONN.
5	4	FF31F1022	PIN, CONTACT, MALE, MOLEX
6	4	FF31F1023	PIN, CONTACT, FEMALE, MOLEX
7	2	TT1818-1	TERMINAL, FAST-ON
8	4"	ZTH3/4B	SHRINK TUBE
9	2	TTMB70473	SMALL WIRE NUT

4003-IS3WT2 Thread Break Sensor

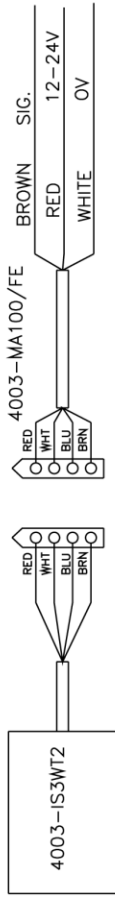

DO NOT CONNECT BLUE WIRE

INSTALL SENSOR SO THE DISC IS CENTERED OVER THE THREAD CONE

TENSION EFFECTS SENSOR PERFORMANCE: LIGHTER THREAD AND SLOWER SPEEDS NEED MORE TENSION

THREAD MUST PASS THROUGH HOLE IN TENSION SHAFT LIFT TENSION DISC TO ACCESS SLOT AND HOLE

EXIT EYELET MUST BE CENTERED ON SENSOR

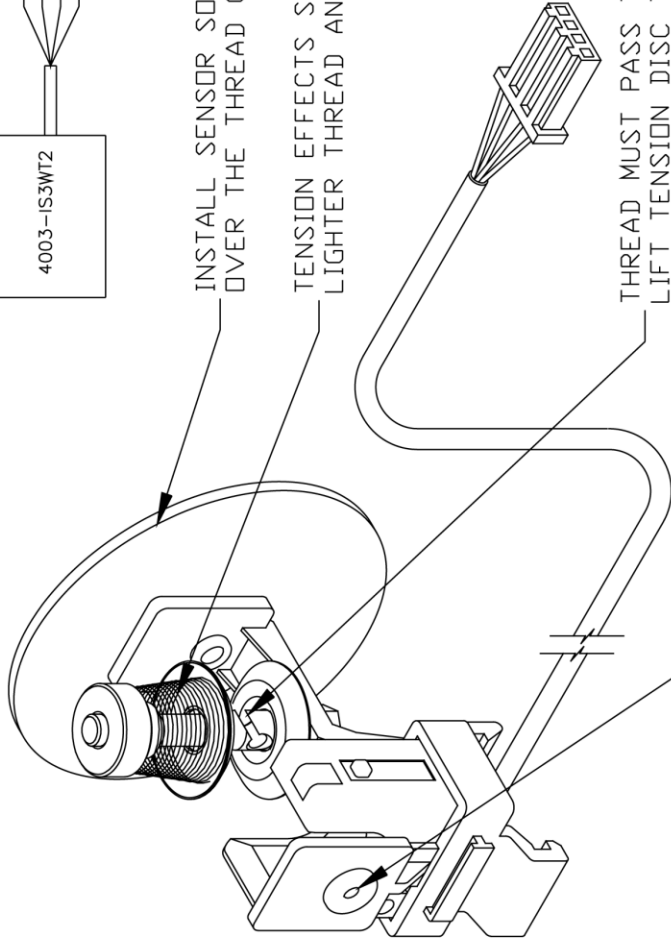

NOTES:

1. SEE 261439A FOR PROGRAM INSTRUCTIONS.

2	357-03	12-18	DW	JT	QTY.	ITEM	DESCRIPTION	PART NO.
1	272-00	8-29	KS	JT	RECD.	NO.	ATLANTA ATTACHMENT COMPANY	STOCK SIZE
NO.	REVISION	DATE	DR.	CK.	FINISH			
					BLAIN			
					BURR BENCH			
					BLACKOXIDE			
					HEAT TREAT			
					SAND BLAST			
					BUFF			
					PAINT TAN			
					CHROMATE			
					TIMESAVE			
					OIL			
					NAME		SENSOR, THREAD BREAK	
					2nd DES.		PROGRAMMED,W/ACCESSORIES	
					MATERIAL		EEIS3WT2	
					ASSEMBLY		.	
					DES. BY		JEFF THOMAS	
					DR. BY		BOB SIDERS	
					CK. BY		BOB SIDERS	
					SCALE		1/1	
					DATE		08/06/99	
					MACH		CL.	
					PART NO.		4003-IS3WT2	
					DRAWING NO.		125715A	
					REV		2	



242-99

The materials contained herein are confidential and proprietary information of Atlanta Attachment Company. In addition to any confidentiality and non-disclosure obligations that currently exist between you and Atlanta Attachment Company, your use of these materials serves as an acknowledgment of the confidential and proprietary nature of these materials and your duty not to make any unauthorized use or disclosure of these materials.

1330-PD Pneumatic Diagram

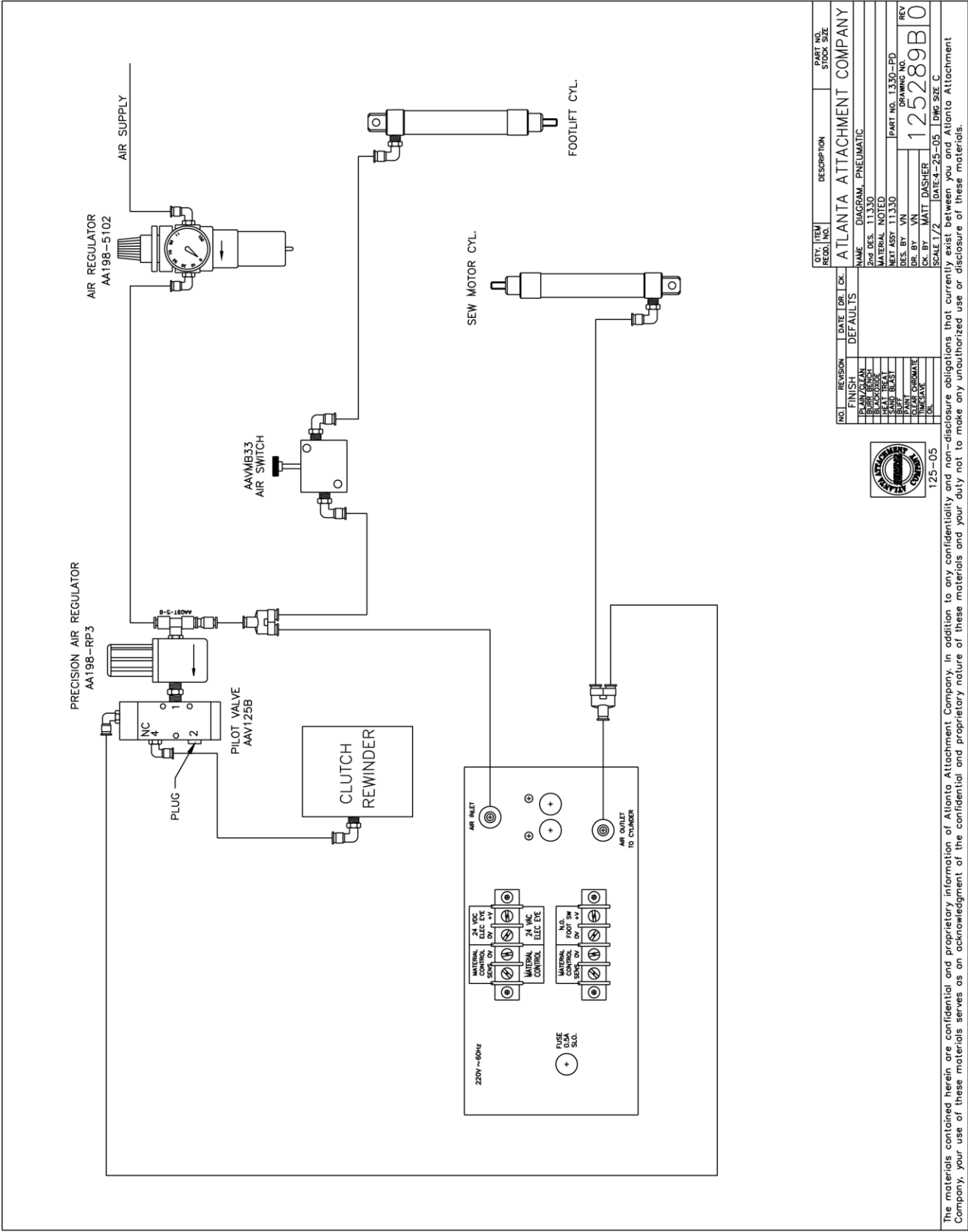

QTY. ITEM RECD. NO.	DESCRIPTION	PART NO. STOCK SIZE
ATLANTA ATTACHMENT COMPANY		
NAME DIAGRAM, PNEUMATIC		
2nd DES. 11.3.30		
MATERIAL NOTED		
NEXT ASSY 13.3.30		
DES. BY VN		
DRA. BY MATT DASHER		
SCALE 1/2 DATE 4-25-05 DWG. SIZE C		
PART NO. 1330-PD		REV
125289B		0



The materials contained herein are confidential and proprietary information of Atlanta Attachment Company. In addition to any confidentiality and non-disclosure obligations that currently exist between you and Atlanta Attachment Company, your use of these materials serves as an acknowledgment of the confidential and proprietary nature of these materials and your duty not to make any unauthorized use or disclosure of these materials.

1347MA-PD Pneumatic Diagram, 1347MA

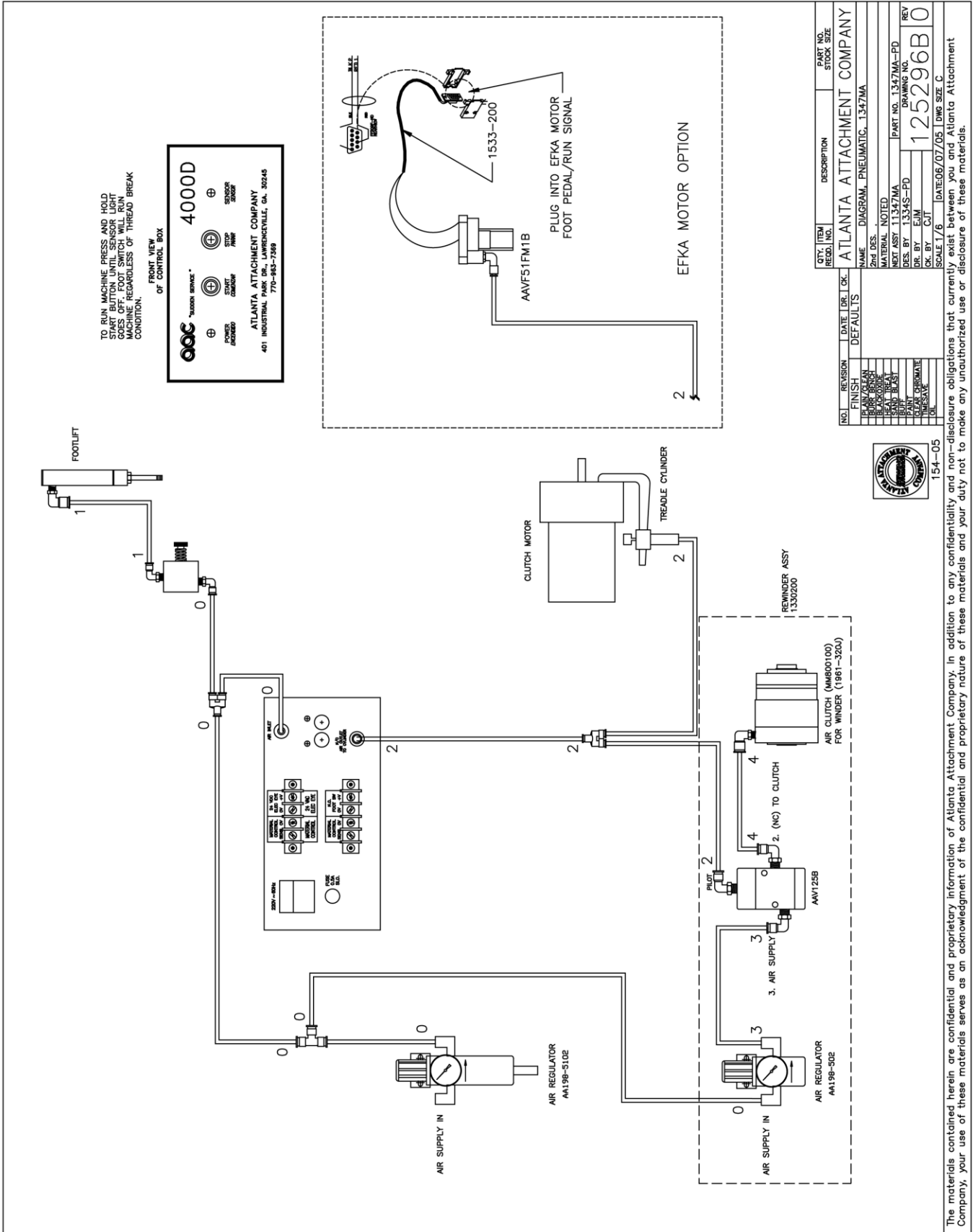

TO RUN MACHINE PRESS AND HOLD
OFF FOOT SWITCH UNTIL LIGHT
GOES OFF. FOOT SWITCH WILL RUN
MACHINE REGARDLESS OF THREAD BREAK
CONDITION.

FRONT VIEW
OF CONTROL BOX

400D
SOLENOID VALVE
ATLANTA ATTACHMENT COMPANY
401 INDUSTRIAL PARK DR., LAWRENCEVILLE, GA. 30245
770-962-7589

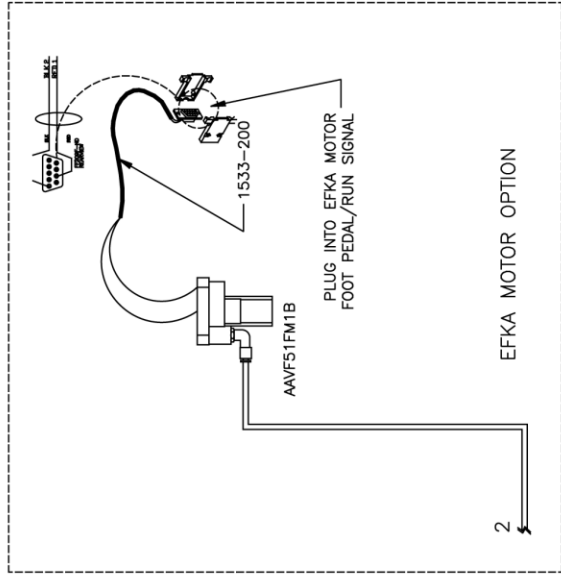

NO.	REVISION	FINISH	DATE	DR.	CHK.	DESCRIPTION	PART NO.	STOCK SIZE
		DEFAULTS				ATLANTA ATTACHMENT COMPANY		
		NAME	DIAGRAM, PNEUMATIC, 1347MA					
		MATERIAL	NOTED					
		DES. BY	1347MA					
		DR. BY	EJM					
		CHK. BY	CJT					
		SCALE	1/6					
		DATE	06/07/05					
		DWG SIZE	C					
		REV	125296B					



154-05

The materials contained herein are confidential and proprietary information of Atlanta Attachment Company. In addition to any confidentiality and non-disclosure obligations that currently exist between you and Atlanta Attachment Company, your use of these materials serves as an acknowledgment of the confidential and proprietary nature of these materials and your duty not to make any unauthorized use or disclosure of these materials.

1330-WD Wiring Diagram

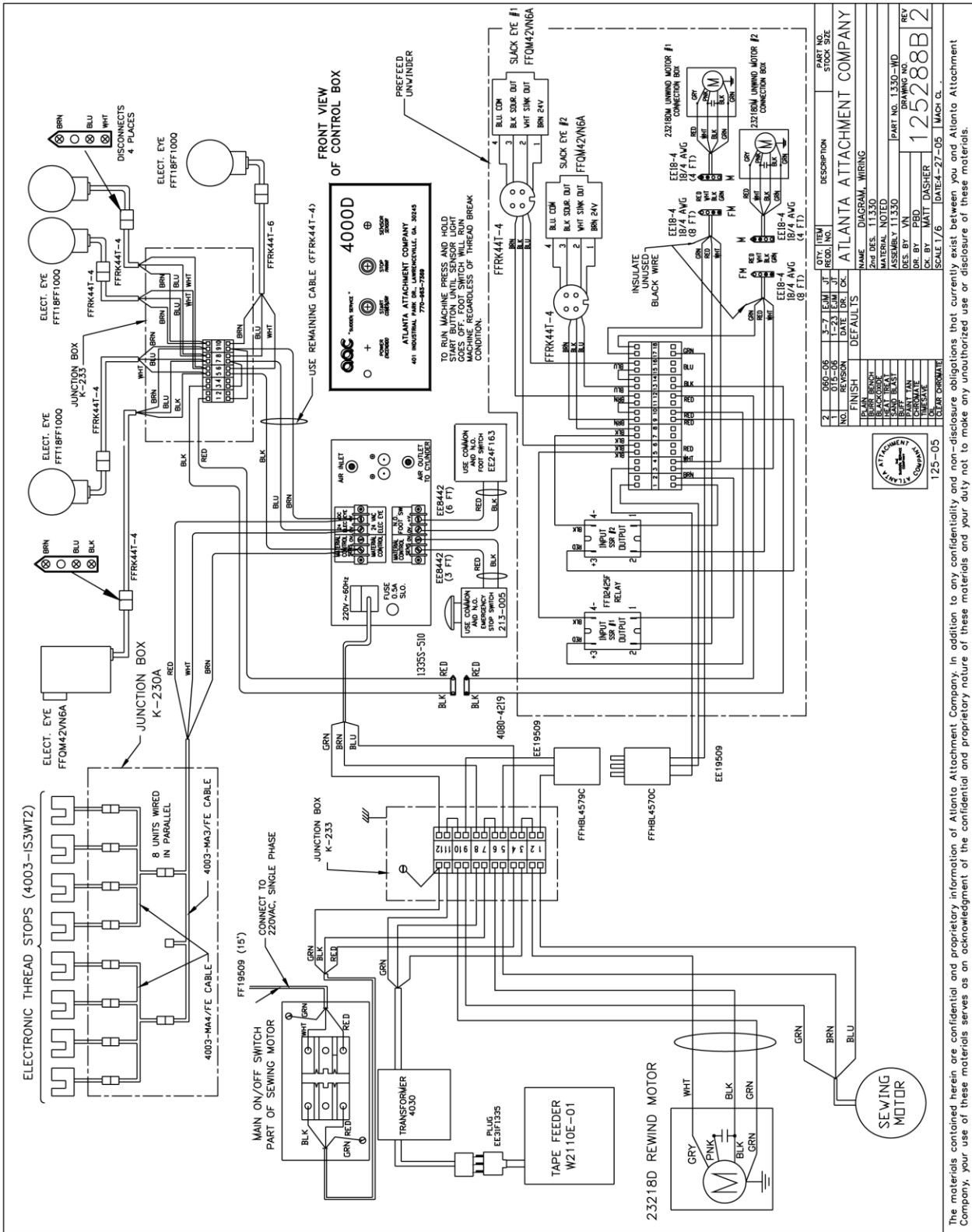

The materials contained herein are confidential and proprietary information of Atlanta Attachment Company. In addition to any confidentiality and non-disclosure obligations that currently exist between you and Atlanta Attachment Company, your use of these materials serves as an acknowledgment of the confidential and proprietary nature of these materials and your duty not to make any unauthorized use or disclosure of these materials.

1347MA-WD Wiring Diagram

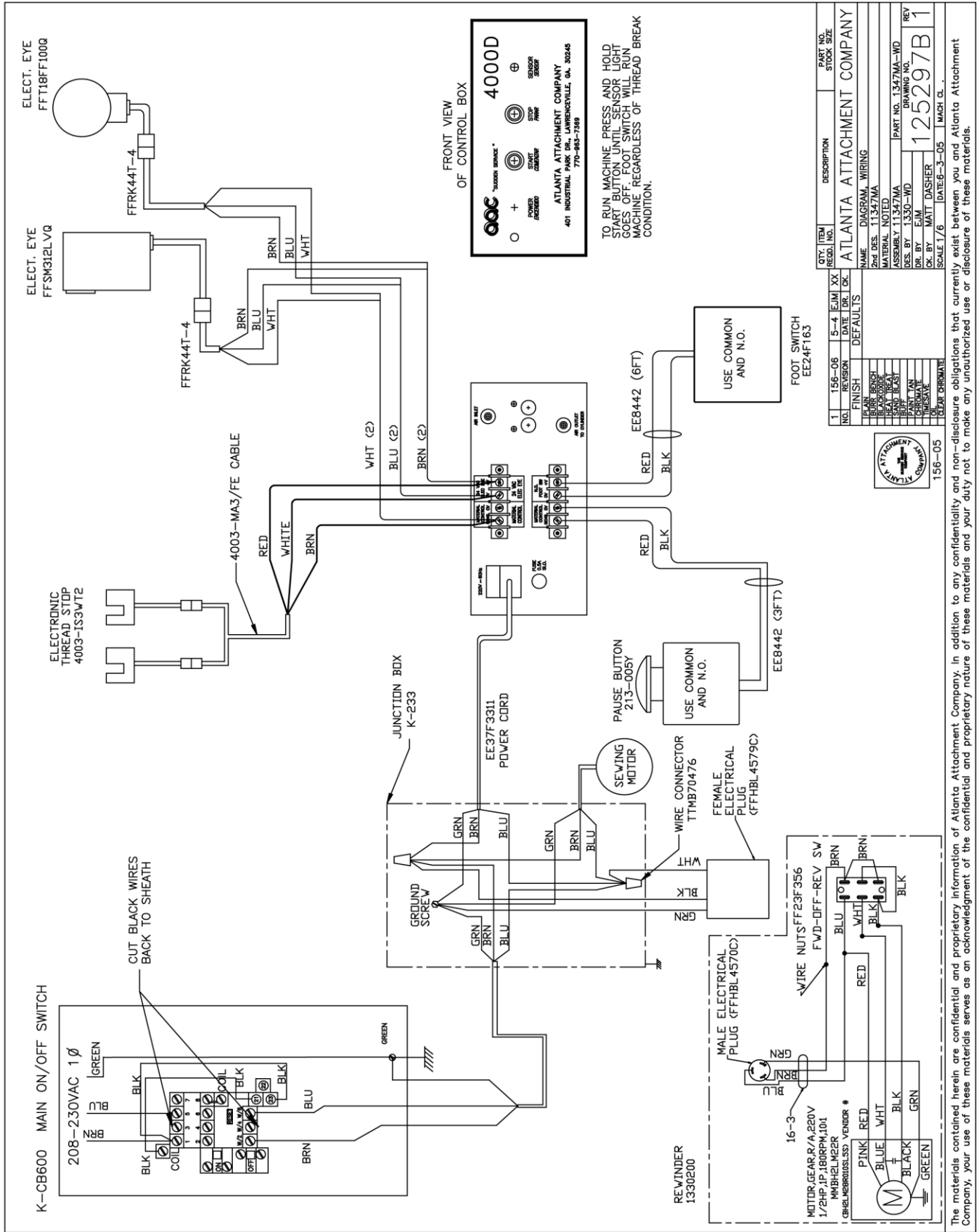

The materials contained herein are confidential and proprietary information of Atlanta Attachment Company. In addition to any confidentiality and non-disclosure obligations that currently exist between you and Atlanta Attachment Company, your use of these materials serves as an acknowledgment of the confidential and proprietary nature of these materials and your duty not to make any unauthorized use or disclosure of these materials.

From the library of: Diamond Needle Corp

1330E-WD Wiring Diagram

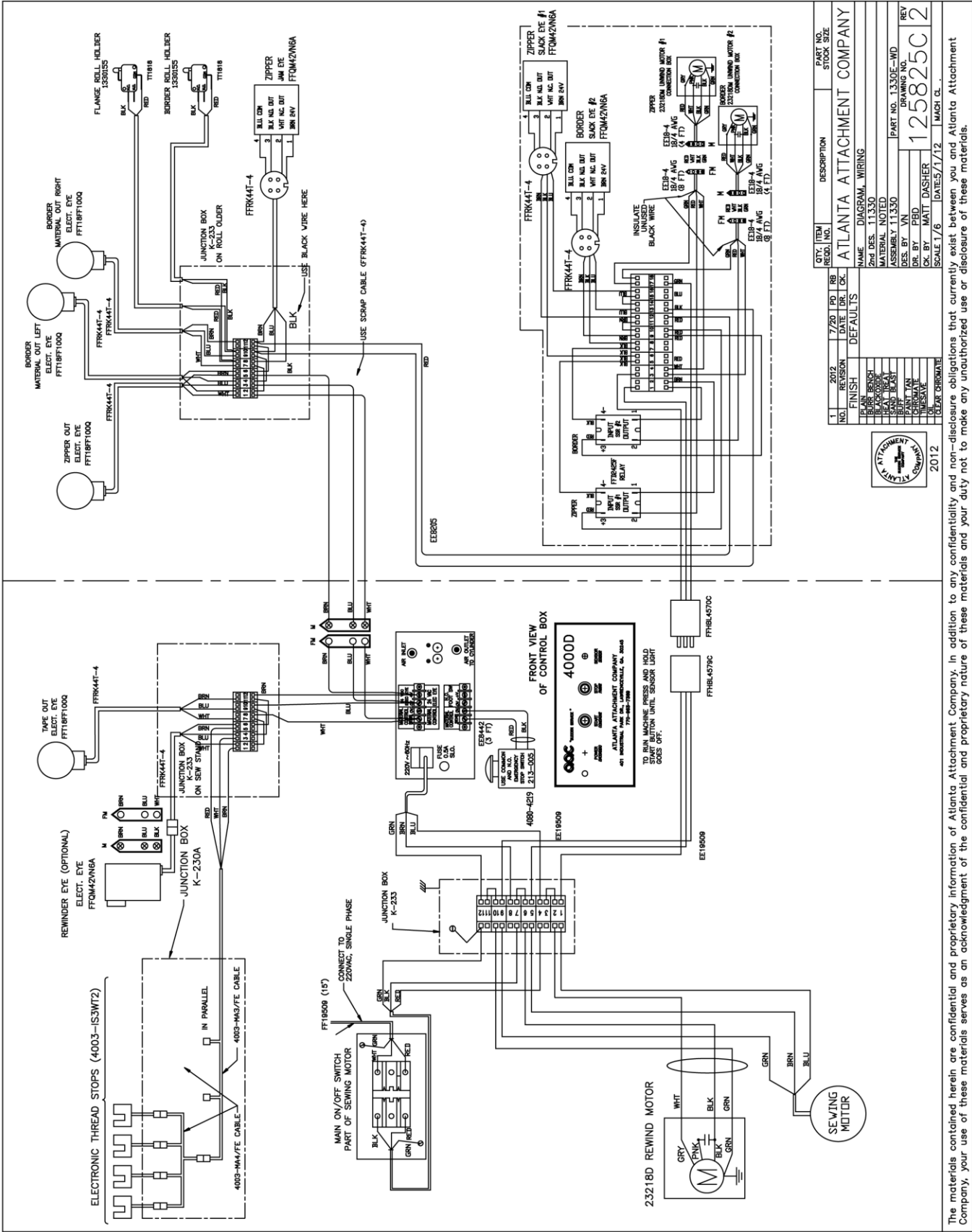

QTY	ITEM	DESCRIPTION	PART NO.	STOCK SIZE
1	7/20	RD	ATLANTA ATTACHMENT COMPANY	
1	REVISION	DATE	BY	CR.
FINISH: DEFAULTS				
NAME: DIAGRAM, WIRING				
2nd DES. 11.3.30				
MATERIAL NOTED				
ASSEMBLY 11.3.30				
DES. BY: VN				
DR. BY: MATT DASHNER				
SCALE: 1/8" = 1" (DATE: 5/1/12) MACH. CL.				
PART NO. 1330E-WD				REV 2
DRAWING NO. 125825C				



The materials contained herein are confidential and proprietary information of Atlanta Attachment Company. In addition to any confidentiality and non-disclosure obligations that currently exist between you and Atlanta Attachment Company, your use of these materials serves as an acknowledgment of the confidential and proprietary nature of these materials and your duty not to make any unauthorized use or disclosure of these materials.

Atlanta Attachment Company (AAC) Statement of Warranty

Manufactured Products

Atlanta Attachment Company warrants manufactured products to be free from defects in material and workmanship for a period of eight hundred (800) hours of operation or one hundred (100) days whichever comes first. Atlanta Attachment Company warrants all electrical components of the Serial Bus System to be free from defects in material or workmanship for a period of thirty six (36) months.

Terms and Conditions:

- AAC Limited Warranty becomes effective on the date of shipment.
- AAC Warranty claims may be made by telephone, letter, fax or e-mail. All verbal claims must be confirmed in writing.
- AAC reserves the right to require the return of all claimed defective parts with a completed warranty claim form.
- AAC will, at its option, repair or replace the defective machine and parts upon return to AAC.
- AAC reserves the right to make the final decision on all warranty coverage questions.
- AAC warranty periods as stated are for eight hundred (800) hours or one hundred (100) days whichever comes first.
- AAC guarantees satisfactory operation of the machines on the basis of generally accepted industry standards, contingent upon proper application, installation and maintenance.
- AAC Limited Warranty may not be changed or modified and is not subject to any other warranty expressed or implied by any other agent, dealer, or distributor unless approved in writing by AAC in advance of any claim being filed.

What Is Covered

- Electrical components that are not included within the Serial Bus System that fail due to defects in material or workmanship, which are manufactured by AAC are covered for a period of eight hundred (800) hours.
- Mechanical parts or components that fail due to defects in material or workmanship, which are manufactured by AAC.
- Purchased items (sewing heads, motors, etc.) will be covered by the manufacturers (OEM) warranty.
- AAC will assist in the procurement and handling of the manufacturers (OEM) claim.

What Is Not Covered

- Parts that fail due to improper usage, lack of proper maintenance, lubrication and/or modification.
- Damages caused by; improper freight handling, accidents, fire and issues resulting from unauthorized service and/or personnel, improper electrical, plumbing connections.
- Normal wear of machine and parts such as Conveyor belts, "O" rings, gauge parts, cutters, needles, etc.
- Machine adjustments related to sewing applications and/or general machine operation.
- Charges for field service.
- Loss of time, potential revenue, and/or profits.
- Personal injury and/or property damage resulting from the operation of this equipment.

Declaración de Garantía

Productos Manufacturados

Atlanta Attachment Company garantiza que los productos de fabricación son libres de defectos de material y de mano de obra durante un periodo de ochocientos (800) horas de operación o cien (100) días cual llegue primero. Atlanta Attachment Company garantiza que todos los componentes del Serial bus son libres de defectos de material y de mano de obra durante un periodo de treinta y seis (36) meses.

Términos y Condiciones:

- La Garantía Limitada de AAC entra en efecto el día de transporte.
- Reclamos de la Garantía de AAC pueden ser realizados por teléfono, carta, fax o correo electrónico. Todo reclamo verbal tiene que ser confirmado vía escrito.
- AAC reserva el derecho para exigir el retorno de cada pieza defectuosa con un formulario de reclamo de garantía.
- AAC va, según su criterio, reparar o reemplazar las máquinas o piezas defectuosas devueltas para AAC.
- AAC reserva el derecho para tomar la decisión final sobre toda cuestión de garantía.
- Las garantías de AAC tiene una validez de ochocientas (800) horas o cien (100) días cual llega primero.
- AAC garantiza la operación satisfactoria de sus máquinas en base de las normas aceptadas de la industria siempre y cuando se instale use y mantenga de forma apropiada.
- La garantía de AAC no puede ser cambiado o modificado y no está sujeto a cualquier otra garantía implicado por otro agente o distribuidor menos al menos que sea autorizado por AAC antes de cualquier reclamo.

Lo Que Está Garantizado

- Componentes eléctricos que no están incluidos dentro del sistema Serial Bus que fallen por defectos de materiales o de fabricación que han sido manufacturados por AAC son garantizados por un periodo de ochocientas (800) horas.
- Componentes mecánicos que fallen por defectos de materiales o de fabricación que han sido manufacturados por AAC son garantizados por un periodo de ochocientas (800) horas.
- Componentes comprados (Motores, Cabezales,) son protegidos debajo de la garantía del fabricante.
- AAC asistirá con el manejo de todo reclamo de garantía bajo la garantía del fabricante.

Lo Que No Está Garantizado

- Falla de repuestos al raíz de uso incorrecto, falta de mantenimiento, lubricación o modificación.
- Daños ocurridos a raíz de mal transporte, accidentes, incendios o cualquier daño como resultado de servicio por personas no autorizados o instalaciones incorrectas de conexiones eléctricas o neumáticas.
- Desgaste normal de piezas como correas, anillos de goma, cuchillas, agujas, etc.
- Ajustes de la máquina en relación a las aplicaciones de costura y/o la operación en general de la máquina.
- Gastos de Reparaciones fuera de las instalaciones de AAC
- Pérdida de tiempo, ingresos potenciales, y/o ganancias.
- Daños personales y/o daños a la propiedad como resultado de la operación de este equipo.



Atlanta Attachment Company
362 Industrial Park Drive
Lawrenceville, GA 30046
770-963-7369
www.atlatt.com

Printed in the USA

From the library of: Diamond Needle Corp